

TIMKEN

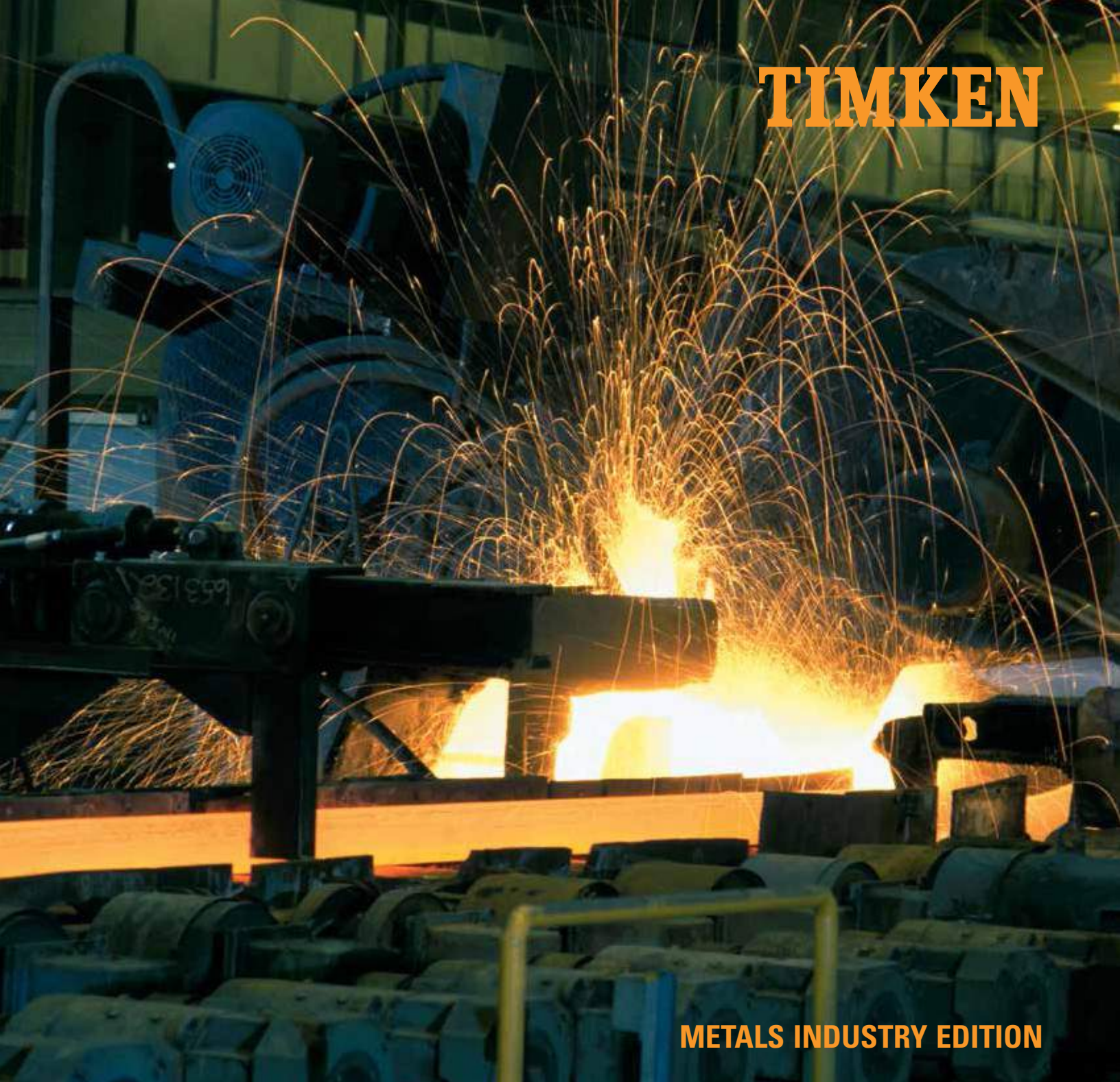

METALS INDUSTRY EDITION

TIMKEN ENGINEERING MANUAL



TIMKEN ENGINEERING MANUAL - METALS INDUSTRY EDITION INDEX

TIMKEN OVERVIEW.....	2	LUBRICATION AND SEALING	95
Shelf Life Policy.....	8	Lubrication	96
Storage	9	Lubrication Fundamentals	96
 		Main Lubricant Characteristics.....	99
POPULAR BEARING TYPES IN THE METAL INDUSTRY	11	Lubrication Selection	100
Steelmaking	12	Sealing.....	110
Continuous Casting.....	13	Sealing Types.....	110
Rolling Mill Stands	14	Sealing Systems.....	112
Radial Bearings	14	 	
Thrust Bearings.....	16	APPLICATION CHALLENGES AND ENHANCED	
Auxiliary Equipment.....	18	BEARING SOLUTIONS.....	115
 		High-Performance Bearings.....	116
APPLICATION CONSIDERATIONS AND BEARING SELECTION.....	21	Contact Fatigue	117
Steelmaking	22	Debris.....	120
Continuous Casting.....	27	Lubrication	122
Rolling Mill.....	33	Corrosion.....	124
Flat Product Rolling.....	33	Precision Rolling	126
Long Product Rolling	35	High Acceleration	127
Bearing Solutions: Radial Positions.....	36	 	
Work and Intermediate Rolls: Flat Product Mills.....	36	RELATED PRODUCTS.....	129
Work Rolls: Long Product Mills	43	Seals and Lubricant.....	130
Backup Rolls	46	Maintenance Tools	131
Bearing Solutions: Axial Positions	53	Condition Monitoring Equipment.....	133
Auxiliary Equipment.....	58	Timken® Housed Units.....	134
Main Mill Drive and Pinion Stand Gearboxes	58	Timken Quick-Flex® Couplings	138
Pay-off and Rewind Reels	60	Precision Chain Products	140
Shears and Shear Drives.....	62	 	
Table Rolls	64	BEARING STORAGE, HANDLING AND INSTALLATION	143
 		Bearing Packaging and Storage	144
BEARING LIFE CALCULATIONS AND RELATED ANALYSIS	67	Bearing Marking	144
Summary of Symbols.....	68	Roll Neck Maintenance Guidelines	147
Fatigue Life.....	69	Chock and Roll Neck Maintenance Guidelines	151
Bearing Ratings.....	69	Mounting and Dismounting Roll Neck Bearings	157
Applied Loads	72	Bearing Setting Techniques.....	168
Bearing Life Equations	81	 	
Bearing Internal Clearance.....	86	SERVICES	175
Advanced Analysis.....	92	Gearbox Repair.....	176
 		Bearing Reconditioning and Reclamation.....	177
		Chock and Roll Upgrades	180
		MILLTEC™ Rolling Mill Program.....	182
		Service Engineering	182
		Training	182

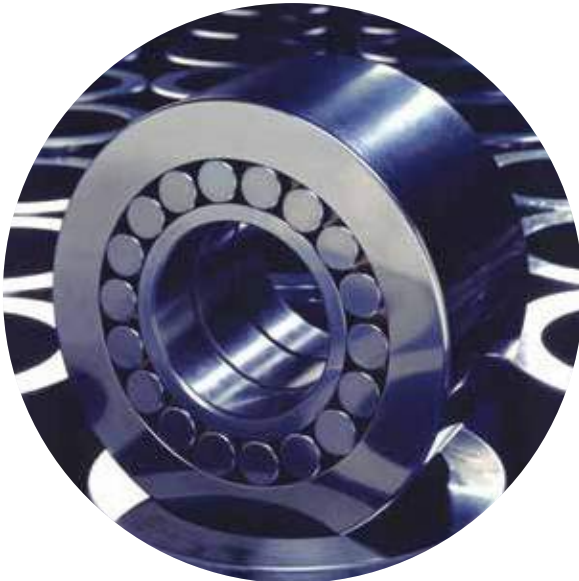

GROW STRONGER WITH TIMKEN

Every day, people around the world count on the strength of Timken. Our expertise in metallurgy, friction management and mechanical power transmission helps them accelerate improvements in productivity and uptime.

We supply products and services that can help keep your operations moving forward, whether you need drive train kits for commercial vehicles, durable housings for bearings in dirty environments, couplings that avoid metal-to-metal contact between motors and gearboxes, repair services for bearings and gearboxes, roller chain for dry, abrasive and high-moisture applications, steel for an aircraft engine shaft, or other products or services for your applications.

When you choose Timken, you receive more than high-quality products and services: you gain a worldwide team of highly trained and experienced Timken people committed to working collaboratively with you to improve your business.

Globally, our 20,000 people provide reliable answers for a wide range of operations in manufacturing, mining, medical equipment, aerospace, transportation, oil and gas – and other diverse industries.

INCREASE YOUR EQUIPMENT UPTIME

In addition to high-quality bearings and mechanical power transmission components, we provide valuable integrated products and services. For example, we offer repair services and equipment monitoring equipment that can alert you to problems before they impact your uptime.

Additionally, we offer a broad selection of seals, premium lubricants, lubricators, couplings and chain to keep your operations moving smoothly.

Our technology centers in the United States, Europe and Asia help pioneer tomorrow's innovations with extensive basic and applied scientific research programs. Through internal development and strategic acquisition of innovative companies, we continue to expand our portfolio of highly engineered bearings and components.



METALS INNOVATOR

Today, metal processing equipment handles heavier loads, faster speeds and greater output than ever before. Finished product quality requirements increase, while across the industry manufacturers continue to place a very high premium on equipment uptime and performance.

As the leader in friction-management and power-transmission solutions for the metals industry, Timken helps metals operators improve their equipment's performance and uptime. We accomplish this by providing custom solutions – from bearings that can stand up to harsh environments to condition monitoring that helps minimize maintenance costs and improve plant productivity.

We have more than a century of experience developing bearings and related solutions that help equipment run more efficiently in a wide range of applications, including steelmaking, continuous casting and rolling both flat and long products.

INNOVATION AND CUSTOMER SUPPORT

Timken operates technology centers around the world dedicated to developing innovative concepts and products that help you operate more efficiently. Our technical leadership and customer support reaches far beyond our products. Timken customers have access to sales and service engineering support at their plants and options for additional support from application engineers, who specialize in the metals industry.

CORE CAPABILITIES

Timken has evolved from its early roots as a bearing and steel producer to a supplier offering much more, including friction-management and power-transmission solutions that add value throughout the complete life cycle of a system. Our material enhancements improve bearing life and can protect against debris and corrosion – two common challenges in processing metals. Our precision manufacturing capabilities and commitment to quality ensure global consistency in design and manufacturing at every Timken facility. A global distribution network provides our customers with easy access to Timken products and services throughout the world.

We leverage these core capabilities as we work with original equipment manufacturers (OEM) and designers to integrate our technologies into equipment so that end users can enjoy the performance benefits of Timken products from the first day of operation. OEMs depend on Timken for our engineering expertise, manufacturing capabilities and emphasis on reliable performance.



PRODUCTS AND SERVICES

We offer equipment builders and operators one of the most extensive friction-management product and service portfolios in the industry.

BEARINGS

We provide a broad range of bearing designs and configurations for use in steelmaking vessels, caster segments, work rolls, backup rolls, screwdown systems, mill drives, pinion stands, coilers, table rolls, and auxiliary equipment.

Bearing types include:

- **Tapered roller bearings** – Tapered roller bearings are uniquely designed to manage both thrust and radial loads and are available in single- and multi-row designs with a wide range of assembly options. Our extensive offering of tapered roller bearing combinations offers equipment builders and operators simple, reliable and less costly design solutions.
- **Cylindrical roller bearings** – This design generally offers the highest possible radial load capacity for a given size compared to other roller bearing types. One row and two row cylindrical roller bearings are ideal for many mill stand, gear drive and other auxiliary equipment applications, while four row cylindrical roller bearings are used in roll neck applications. Timken offers both single and multi-row cylindrical roller bearing. Custom designs are available upon request for specific applications.
- **Spherical roller bearings** – Spherical roller bearings offer high radial and moderate thrust capacity together with maximum static and dynamic misalignment capability. Timken spherical roller bearings provide high-static load capacity and advanced geometry that reduces friction and heat generation. These bearings are available in a range of dimensionally stabilized configurations to suit elevated operating temperatures.
- **Thrust roller bearings** – Thrust roller bearings for rolling mill applications are available in cylindrical, spherical and tapered designs. Thrust bearings are ideal for applications experiencing heavy axial loads, such as mill stands, screwdown systems and piercing mills.
- **Ball bearings** – Ball bearings are used extensively in auxiliary applications that have light loads and/or high speed conditions. Timken offers a range of radial, thrust and angular-contact ball bearings in both metric and inch sizes. Please contact your Timken engineer for detailed information on these product ranges.
- **Housed units** – Timken® spherical roller bearing solid-block housed units possess a unique cast-steel design that handles demanding conditions in metal industry applications. These solid-block housed units come in several styles and five advanced locking configurations. Timken spherical roller bearing solid-block housed units are designed for challenging circumstances. A full line of primary seals, covers and housings is available to find the right roller housed unit to fit your application. In case of high thrust loads, in excess of the spherical roller bearing carrying capabilities, the Timken® Type E is your solution. Timken also provides a broad range of split-block housings in both metric and inch sizes.

HIGH-PERFORMANCE BEARING SOLUTIONS

Timken provides the metals industry with a variety of high-performance bearing solutions, including Timken® AquaSpexx®, DuraSpexx® and thin dense chrome bearings for corrosion protection. Our debris-resistant bearings are ideal for contaminated and/or marginal lubrication conditions.

We also provide customized bearing solutions such as special race profiles to meet special application requirements.

In addition to component geometry and metallurgy, we find many ways to enhance bearing performance by applying unique surface finishes and special coatings on rollers, raceways and other functional surfaces. Engineered surfaces and topographical modification reduce surface roughness to lower levels than can be achieved through conventional grinding and honing methods. We also offer proprietary coatings that can create a surface up to four times harder than steel with twice the elasticity. For more information on Timken high-performance bearings and engineered surfaces, see the Application Challenges and Enhanced Bearing Solutions section of this manual (pages 115-127).

POWER TRANSMISSION COMPONENTS AND SYSTEMS

Timken offers an expanding range of power transmission components including seals, couplings and engineered chain.

Extreme temperatures and high contamination levels can disable your equipment and significantly lower productivity. Timken develops seals using advanced material and process solutions that help protect machinery and minimize plant downtime. We offer a comprehensive line of large-bore oil and grease seals and metallic and non-metallic bearing isolators.

Timken® Quick-Flex® couplings are highly durable, yet need minimal maintenance. They are easy to install and require no lubrication. These couplings are designed to connect motors and gearboxes with other moving equipment with capacity to transmit the same or more torque than a gear coupling with the same dimensions. The Quick-Flex coupling's innovative design utilizes an advanced elastomeric element to transmit the torque and therefore eliminates any interference between coupling hubs that can damage equipment.



Timken manufactures precision roller chain that are designed to meet demanding steel industry applications. We build chains to precise specifications for strength and maximum wear life. The offering includes a complete line of roller chain, attachment chain and engineered conveyor chain.



LUBRICATION

Timken lubricants reduce friction, reduce wear and protect bearing surfaces from corrosion. We offer a wide selection of lubricants, including Timken Mill Grease, which we formulated to perform in the difficult roll neck bearing environment. Timken single- and multi-point lubricators and lubrication delivery devices help mill maintenance professionals simplify their lubrication practices, saving time and money.

CONDITION MONITORING

A constant awareness of your mill equipment's condition can help avoid unscheduled and costly downtime. Timken offers a full line of condition-monitoring equipment including handheld devices and continuous monitoring systems. Our range of monitoring systems meet the various needs of your mill from simple alarms to complex data collection. These products allow you to detect and correct problems before they cause damage or total system shutdown.



MAINTENANCE TOOLS

Timken maintenance tools may extend bearing life by facilitating proper installation, removal and service. They also help simplify maintenance practices. We provide induction heaters, impact fitting tools and hydraulic and mechanical pullers.

SERVICES

Used bearings and related components often can be returned to their original specifications with less time and costs than purchasing new. We offer complete remanufacture and reconditioning services for many components, including bearings, chocks, housings, rolls and more.

Our gearbox repair services are globally recognized as experts in power transmission solutions for heavy industrial markets, repairing virtually any large gearbox make or model, with onsite emergency breakdown service available if needed.

Timken offers a full range of maintenance and reconditioning services through our remanufacturing and repair operations. Using these services can lead to improved plant efficiency and reduced overall production costs.

Beyond bearing repair and depending on the location, we offer chock maintenance and roll rebuilding to help mill operators get the most out of their chock/bearing assembly.

In addition, our MILLTEC® rolling mill program provides around-the-clock management of the roll shop with the goal of minimizing operational costs and downtime.



TRAINING

We offer industry-specific training programs designed for plant professionals, as well as on-site customized training to meet your specific needs. Our metals industry training programs are available at select locations around the world and cover every phase of bearing performance in the metal-making environment. Class time is balanced with extensive hands-on training and tours of Timken facilities.

HOW TO USE THIS CATALOG

We designed this catalog to help you find the bearings best suited to your specifications.

Timken offers an extensive range of bearings and accessories in both imperial and metric sizes. For your convenience, size ranges are indicated in millimeters and inches. Contact your Timken sales engineer to learn more about our complete line for the special needs of your application.

This publication contains dimensions, tolerances and load ratings, as well as engineering sections describing fitting practices for shafts and housings, internal clearances, materials and other bearing features. It provides valuable assistance in the initial consideration of the type and characteristics of the bearings that may best suit your particular needs.

ISO and ANSI/ABMA, as used in this publication, refer to the International Organization for Standardization and the American National Standards Institute/American Bearing Manufacturers Association.

Updates are made periodically to this catalog. Visit www.timken.com for the most recent version of the Timken Metals Engineering Catalog.

DISCLAIMER

This catalog is provided solely to give you analysis tools and data to assist you in your product selection. Product performance is affected by many factors beyond the control of Timken. Therefore, you must validate the suitability and feasibility of all product selections.

Timken products are sold subject to Timken terms and conditions of sale, which include our limited warranty and remedy. You can find these at <http://www.timken.com/en-us/purchase/Pages/TermsandConditionsofSale.aspx>

Please consult with your Timken engineer for more information and assistance.

Every reasonable effort has been made to ensure the accuracy of the information in this writing, but no liability is accepted for errors, omissions or for any other reason.

SHELF LIFE AND STORAGE OF GREASE-LUBRICATED BEARINGS AND COMPONENTS

To help you get the most value from our products, Timken provides guidelines for the shelf life of grease-lubricated ball and roller bearings, components and assemblies. Shelf life information is based on Timken and industry test data and experience.

SHELF LIFE POLICY

Shelf life should be distinguished from lubricated bearing/component design life as follows:

Shelf life of the grease-lubricated bearing/component represents the period of time prior to use or installation.

The shelf life is a portion of the anticipated aggregate design life. It is impossible to accurately predict design life due to variations in lubricant bleed rates, oil migration, operating conditions, installation conditions, temperature, humidity and extended storage.

Shelf life values, available from Timken, represent a maximum limit and assume adherence to the storage and handling guidelines suggested in this catalog or by a Timken associate. Deviations from the Timken storage and handling guidelines may reduce shelf life. Any specification or operating practice that defines a shorter shelf life should be used.

Timken cannot anticipate the performance of the grease lubricant after the bearing or component is installed or placed in service.

TIMKEN IS NOT RESPONSIBLE FOR THE SHELF LIFE OF ANY BEARING/COMPONENT LUBRICATED BY ANOTHER PARTY.

European REACH Compliance

Timken lubricants, greases and similar products sold in standalone containers or delivery systems are subject to the European REACH (Registration, Evaluation, Authorization and Restriction of Chemicals) directive. For import into the

European Union, Timken can sell and provide only those lubricants and greases that are registered with ECHA (European Chemical Agency). For further information, please contact your Timken engineer.

STORAGE

Timken suggests the following storage guidelines for our finished products (bearings, components and assemblies, referred to as "products"):

- Unless directed otherwise by Timken, products should be kept in their original packaging until they are ready to be placed into service.
- Do not remove or alter any labels or stencil markings on the packaging.
- Products should be stored in such a way that the packaging is not pierced, crushed or otherwise damaged.
- After a product is removed from its packaging, it should be placed into service as soon as possible.
- When removing a product that is not individually packaged from a bulk pack container, the container should be resealed immediately after the product is removed.
- Do not use product that has exceeded its shelf life as defined in the Timken shelf life guidelines statement.
- The storage area temperature should be maintained between 0° C (32° F) and 40° C (104° F); temperature fluctuations should be minimized.
- The relative humidity should be maintained below 60 percent and the surfaces should be dry.
- The storage area should be kept free from airborne contaminants such as, but not limited to, dust, dirt, harmful vapors, etc.
- The storage area should be isolated from undue vibration.
- Extreme conditions of any kind should be avoided.

Due to the fact that Timken is not familiar with your particular storage conditions, we strongly suggest following these guidelines. However, you may be required by circumstances or applicable government requirements to adhere to stricter storage requirements.



Most bearing components typically ship protected with a corrosion-preventive compound that is not a lubricant. These components may be used in oil-lubricated applications without removal of the corrosion-preventive compound. When using some specialized grease lubrications, we advise you to remove the corrosion-preventive compound before packing the bearings components with suitable grease.

We pre-pack most housed unit types in this catalog with general-purpose grease suitable for their normal applications. It may be necessary for you to frequently replenish the grease for optimum performance.

Be careful in selecting lubrication, however, since different lubricants are often incompatible. You may order housed units pre-lubricated with a specified lubrication.

When you receive a bearing or housed unit shipment, do not remove products from their packaging until they are ready for mounting so they do not become corroded or contaminated.

Store bearings and housed units in an appropriate atmosphere so they remain protected for the intended period.



WARNING *Failure to observe the following warnings could create a risk of serious injury.*

Proper maintenance and handling practices are critical.
Always follow installation instructions and maintain proper lubrication.

Warnings for this product line are in this catalog and posted on
www.timken.com/en-us/products/warnings/Pages/default.aspx.

CAUTION *Failure to follow these cautions may result in property damage.*

If hammer and bar are used for installation or removal of a part, use a mild steel bar (e.g., 1010 or 1020 grade). Mild steel bars are less likely to cause release of high-speed fragments from the hammer, bar or the part being removed.

Do not use damaged housed units. The use of a damaged housed unit can result in equipment damage and/or injury.

NOTE

*Do not attempt to disassemble unitized bearings.
Components may become damaged and affect the performance and service life of the bearing.
Do not mix components of matched assemblies. Mixing components can reduce the service life of the bearing.*

DISCLAIMER

*This catalog is provided solely to give you analysis tools and data to assist you in your product selection.
Product performance is affected by many factors beyond the Control of Timken.
Therefore, the suitability and feasibility of all product selection must be validated by you.
Timken products are sold subject to Timken's terms and conditions of sale, which include its limited warranty and remedy,
which terms may be found at <http://www.timken.com/en-us/purchase/Pages/TermsandConditionsofSale.aspx>.
Please consult with your Timken engineer for more information and assistance.
Every reasonable effort has been made to ensure the accuracy of the information in this writing,
but no liability is accepted for errors, omissions or for any other reason.*

To view the complete engineering catalog, please visit www.timken.com. To order the catalog, please contact your Timken engineer and request a copy of the Timken Engineering Manual, order number 10424.

European REACH compliance *Timken-branded lubricants, greases and similar products sold in stand-alone containers or delivery systems are subject to the European REACH (Registration, Evaluation, Authorization and Restriction of CHemicals) directive. For import into the European Union, Timken can sell and provide only those lubricants and greases that are registered with ECHA (European CHemical Agency). For further information, please contact your Timken engineer.*

*Updates are made periodically to this catalog.
Visit www.timken.com for the most recent version of the Timken® Engineering Manual - Metals Industry Edition.*

POPULAR BEARING TYPES IN THE METALS INDUSTRY

The following applications are covered in this section:

- Steelmaking.
- Continuous casting.
- Rolling mill stands.
 - Radial bearings.
 - Thrust bearings.
- Auxiliary equipment.

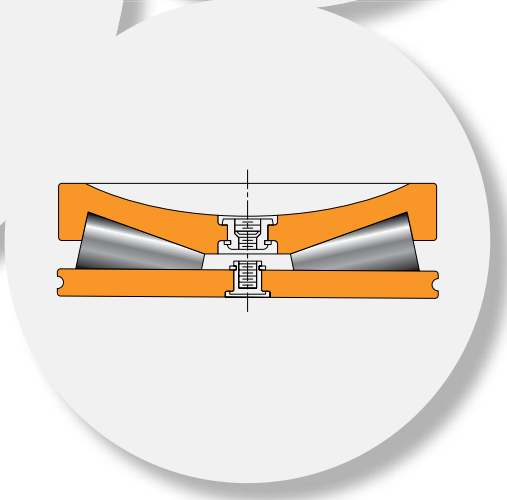
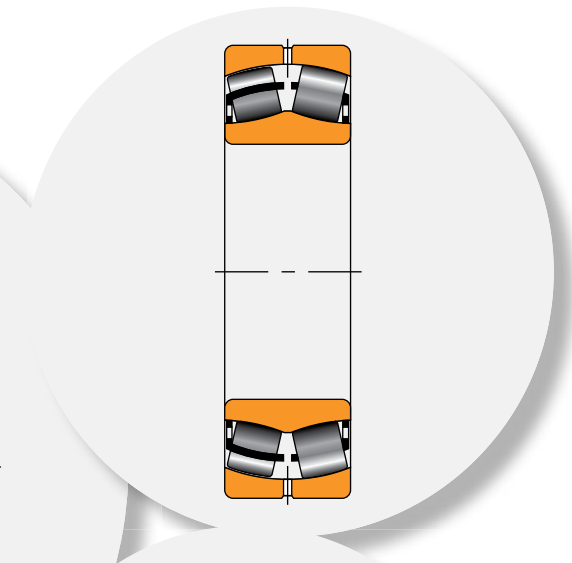
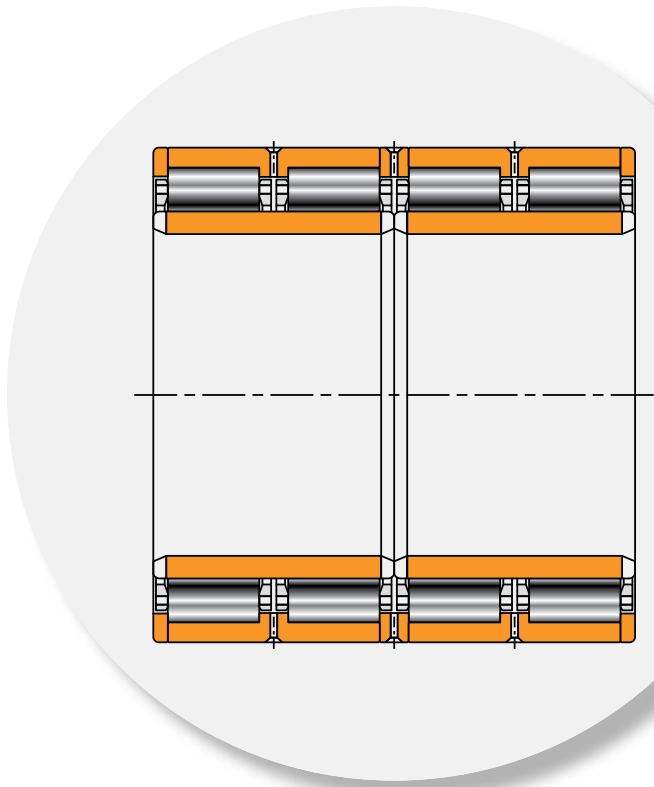
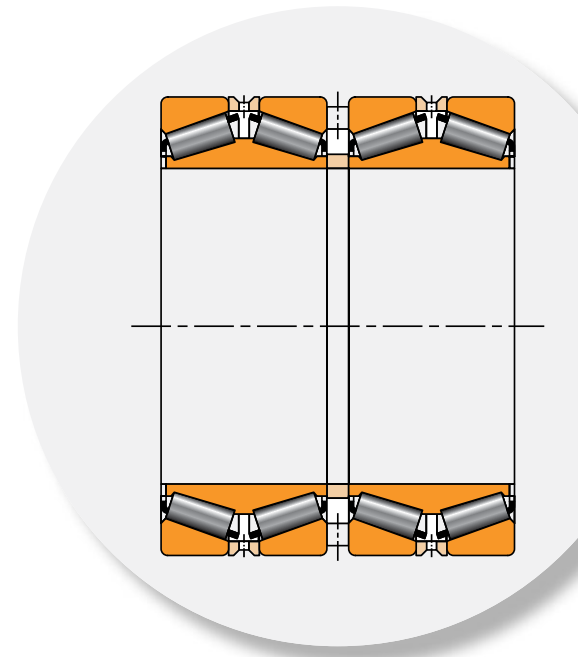

STEELMAKING

The main support positions for the ladle furnace present a challenging application for bearings. They experience very high loads and misalignment at very low speeds. In addition, cyclic and reversing rotation occurs. The Timken solution uses solid or split high-performance spherical roller bearings mounted in custom-designed housings. The float position housing incorporates cylindrical roller ladder bearings to accommodate the significant thermal axial growth of the furnace assembly.

SPHERICAL ROLLER BEARINGS

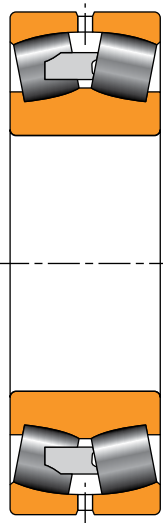

EM TYPE

Composition: One double inner ring, one double outer ring, two rows of spherical rollers with roller-riding brass cage(s).

Application: Basic oxygen furnace (BOF) or argon oxygen decarburization (AOD) furnace pivots (trunnions).

Remarks: EM-type bearings are designed to manage high radial loads when shaft deflection is important.

Fig. 1. EM type.

LADDER BEARINGS

CYLINDRICAL ROLLER TYPE

Composition: One top plate, one bottom plate, cylindrical rollers with spring-centered retainer and one bottom seat.

Application: Linear bearing for float side BOF or AOD furnace pivot bearing assembly.

Remarks: Used in pairs to provide ± 65 mm (2.5 in.) axial float.

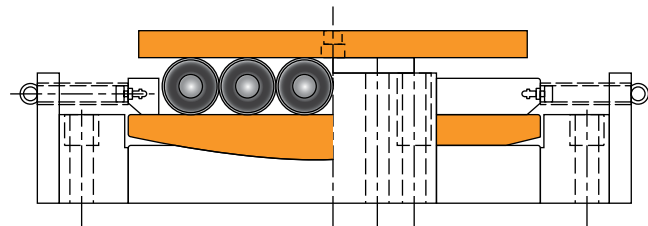
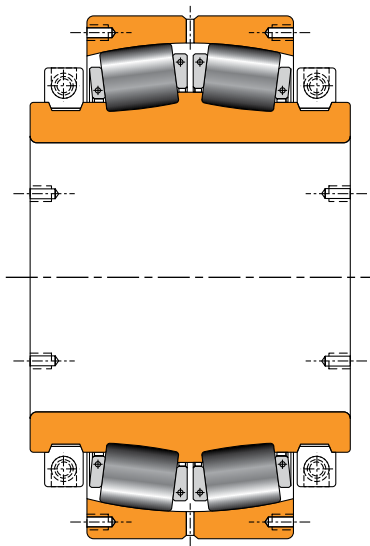

Fig. 3. Cylindrical roller type.



SPLIT TYPE

Composition: One split double inner ring with clamp rings, one split double outer ring, two rows of spherical rollers with brass split cages.

Application: BOF or AOD furnace pivots (trunnions).

Remarks: Often used to replace conventional spherical roller bearings on drive-side pivot (trunnion).

Fig. 2. Split type.

CONTINUOUS CASTING

The continuous caster presents one of the most challenging environments for bearings. Caster-roll support bearings are subjected to high loads and low rotational speeds, often at elevated temperatures. Below the bender segments, the Timken ideal solution combines our high-performance spherical roller bearing for the fixed position and our latest design innovation, the Timken® ADAPT™ bearing, for the floating position.

NEEDLE ROLLER BEARINGS

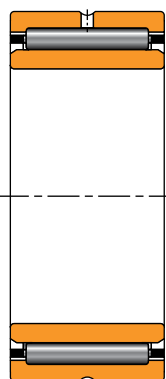

NA TYPE

Composition: One single inner ring, one single outer ring, one row of caged needle rollers.

Application: Bender section support rolls.

Remarks: Low radial cross section with high radial dynamic and static load rating. Available with special clearance and higher stabilizing heat treatment to accommodate continuous caster operating conditions.

Fig. 4. NA type.

CYLINDRICAL ROLLER BEARINGS

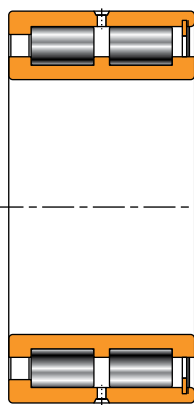

NNCF TYPE

Composition: One double inner ring, one double outer ring, two rows of full-complement cylindrical rollers.

Application: Continuous caster bender section support rolls.

Remarks: Available with special clearance and higher stabilizing heat treatment to accommodate continuous caster operating conditions. This type includes integral flanges on inner and outer rings and can manage light axial loads in one

Fig. 5. NNCF type.

direction and permit small axial displacement.

SPHERICAL ROLLER BEARINGS

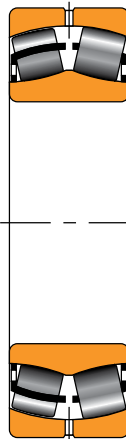

EJ TYPE

Composition: One double inner ring, one double outer ring and two rows of spherical rollers with stamped steel cages.

Application: Caster rolls; fixed and float positions.

Remarks: EJ-type spherical roller bearings feature a hardened stamped steel window-type cage with face slots for improved lubrication. Designed to accept misalignment during operation and with high radial load capacity for maximum reliability.

Fig. 6. EJ type.



ADAPT™

Composition: One single cylindrical inner ring, one single profiled outer ring, full-complement design with a roller/retainer assembly.

Application: Caster rolls; float position.

Remarks: The ADAPT full-complement roller bearing is designed specifically for continuous casters, combining traditional cylindrical and spherical roller bearing configurations into a new design so operators benefit from the key attributes of both types (simultaneous full misalignment and high axial displacement capabilities). This bearing also offers high-static radial load capacity for optional reliability.

Fig. 7. ADAPT™.

WARNING

Failure to observe the following warnings could create a risk of serious injury.

ADAPT™ bearings feature a separable inner ring. Care must be taken when handling or installing a fully assembled bearing to prevent the inner ring from accidentally sliding out of the assembly. When using this bearing to replace a unitized bearing it is important to check the design of the installation for positive retention on the shaft.

Proper maintenance and handling practices are critical.

Always follow installation instructions and maintain proper lubrication.

ROLLING MILL STANDS

Rolling mill applications typically encounter very high radial loads and varying degrees of axial load while running at slow to high-speed. To accommodate these operating conditions, roll neck bearings must have enhanced contact surfaces, material strength properties, and internal geometry and cage characteristics. Available designs include two-, four- or six-row tapered roller bearings, and multi-row cylindrical bearings.

RADIAL BEARINGS

TAPERED ROLLER BEARINGS

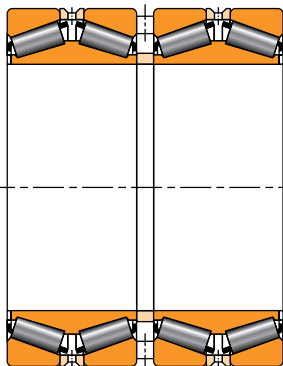

Fig. 8. TQOW.

TQOW

Composition: Two double cones with tapered rollers, one cone spacer, two single cups, two cup spacers, one double cup.

Application: Work rolls, intermediate rolls and backup rolls. Typically used in mills with speeds up to 800 m/min. (2600 ft./min.) when used on backup rolls.

Remarks: The TQOW is a preset four-row assembly with hardened cone spacers to minimize face wear. The bearing clearance in the TQOW design can be reset after extended use by regrinding the spacers.

The bearing is mounted loose on the roll neck and in the chock. Slots on the cone faces provide lubrication access to cone and fillet ring faces for reduced wear. Available with spiral bore groove for additional lubrication access to the roll neck.

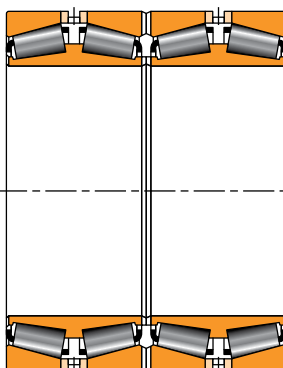

Fig. 9. 2TDIW.

2TDIW

Composition: Two double cones with tapered rollers, four single cups, and two or three cup spacers.

Application: Work rolls, intermediate rolls and backup rolls. Typically used in mills with speeds up to 800 m/min. (2600 ft./min.) when used on backup rolls.

Remarks: The 2TDIW type interchanges with the TQOW type on external boundary dimensions and achieves the same load rating. Under combined axial and radial loads, the two central single cups of the 2TDIW bearing offer better load distribution than the double cups used in the TQOW type.

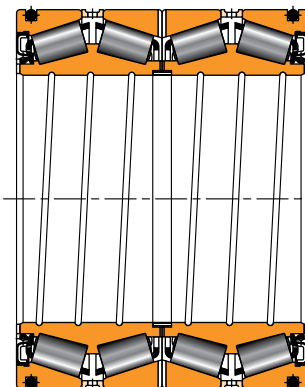

Fig. 10. Sealed roll neck bearing.

Sealed roll neck bearing

Composition: Same construction as the 2TDIW, plus two main seals, one bore seal, and O-ring to seal statically in the chock bore.

Application: Primarily used in work rolls and intermediate rolls and some backup rolls.

Remarks: The sealed roll neck bearing is supplied as a unitized, preset assembly with or without grease.

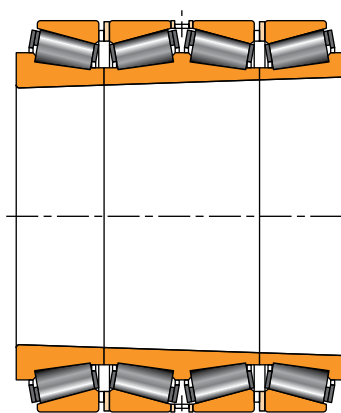

Fig. 11. TQITS.

TQITS

Composition: One double cone and two single cones all with matched tapered bores, four single cups, three cup spacers.

Application: Backup rolls, typically used in high-speed mills where strip speeds exceed 800 m/min. (2600 ft./min.).

Remarks: The TQITS type mounts tight using a 1:12 taper on the roll neck and the bearing bore for accurate control of the interference fit. Typically used on high-speed mills to minimize neck wear.

CYLINDRICAL ROLLER BEARINGS

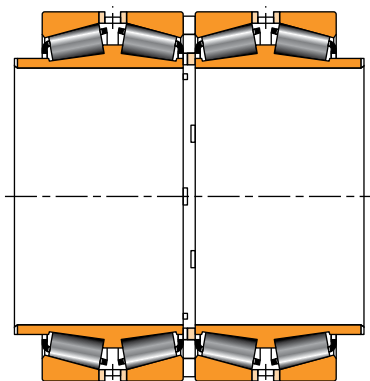

Fig. 12. TQOWE.

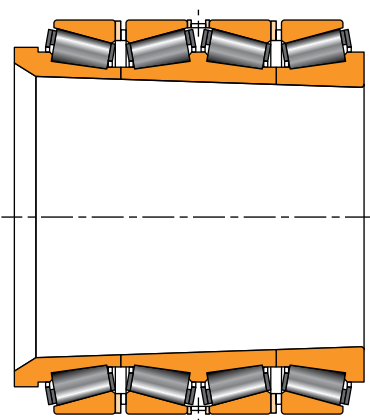

Fig. 13. TQITSE.

TQOWE and TQITSE

Composition: Same construction as the TQOW and TQITS respectively with cone extension on one or both sides of the bearing.

Application: Work rolls, intermediate rolls and backup rolls.

Remarks: The TQOWE and TQITSE versions include cone extensions to accommodate chock seals. This bearing design allows an optimal chock seal running surface. The seal integration permits the bearing to be positioned closer to the roll face, which improves the neck stiffness.

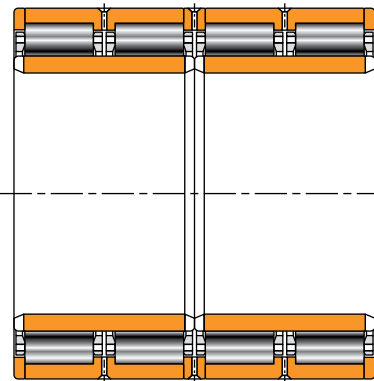

Fig. 14. RX.

RX

Composition: Two cylindrical inner rings, two flanged outer rings and separated rib rings for roller spacing. Typically includes a pin-type cage(s).

Application: Backup roll radial position for flat product mills. Roll neck for long product mills.

Remarks: The bearing is mounted tight on the roll neck and loose in the chock when used on backup rolls. Generally provided with semi-finished (CF) inner ring races to be finished ground by the customer once mounted on the roll neck. Separated rib rings allow for complete disassembly for inspection. The RX style is usually preferred in bearings above 400 mm (15.75 in.) bore. Long product mill applications are generally supplied as preset assembly and mounted tight on the roll neck.

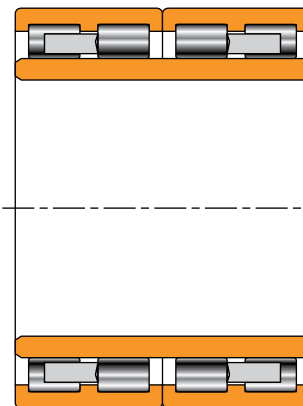

Fig. 15. RY and RYL.

RY and RYL

Composition: Typically one single-piece inner ring, two outer rings with triple flanges (solid ribs). Fully machined brass (RY) or steel (RYL) cages.

Application: Roll neck for long product mills.

Remarks: The most recent RYL design is specifically designed for long-product mills and features a machined-steel cage and enhanced design features to maximize bearing life and optimize bearing handling. For specific applications, four-row cylindrical roller bearings also can be supplied with spiral grooves on inner ring bore, extended inner rings or tapered bore.

THRUST BEARINGS

Applications mounted with cylindrical roller bearings, oil-film bearings or systems with axial shift or roll crossing, generally need an additional thrust bearing.

TAPERED ROLLER THRUST BEARINGS

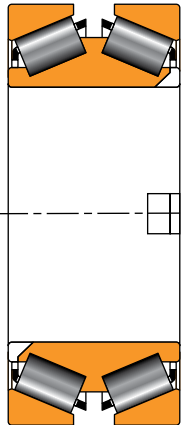

TDIK

Composition: One double cone with tapered rollers, two single cups, spacer or spacerless.

Application: Backup and work roll thrust positions for flat product mills.

Remarks: These bearings come designed with steep angles to accommodate thrust in both directions. Cups and cones are mounted with a loose fit. The cone is keyed onto the shaft to prevent cone rotation and bore fretting.

Fig. 16. TDIK.

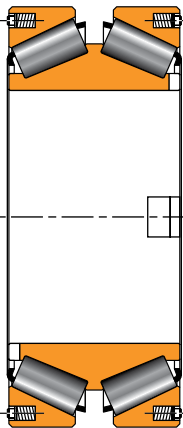

TDIK with spring system

Timken developed a version with a spring system in the cups without a spacer to ensure that the unloaded cup always remains seated and to help prevent any roller skewing.

Application: Work rolls, intermediate rolls with axial shift, and backup roll equipped with cylindrical roller bearing.

Fig. 17. TDIK with spring system.

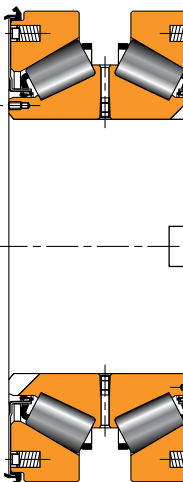

TDIK sealed with spring system

Timken developed the sealed version of the TDIK with a spring system.

Application: Work rolls, intermediate rolls with axial shift, and backup roll equipped with cylindrical roller bearing.

Fig. 18. TDIK with sealed spring system.

TTDWK and TTDFLK

Composition: One double central ring with tapered rollers, two outer rings.

Application: Heavy-duty flat product mills with axial shift and long product mills.

Remarks: Double-acting thrust bearings come available in two versions with tapered central ring or flat central ring. Mounted loose on the neck and in the housing.

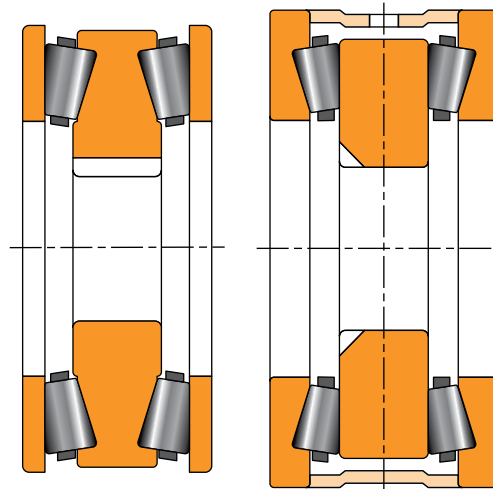

Fig. 19. TTDWK.

Fig. 20. TTDFLK.

The tapered central ring version enables a smaller overall width of the bearing. These TTDFLK assemblies can be provided with or without an outer spacer. However, we generally prefer to use the design without outer spacers and include a spring mounting in the chock shoulders to ensure that the rollers of both rows remain properly seated (see configuration on page 55).

TTHD

Composition: Two tapered thrust rings, cage or cageless.

Application: Thrust positions for piercing mills, sendzimir mills and auxiliary equipment.

Remarks: This design offers up to 40 percent more capacity than cylindrical and spherical bearings with the same envelope dimensions. Used only when axial loads are unidirectional. Medium speed capability when provided with a cage. A cageless design is available for high loads and low speeds.

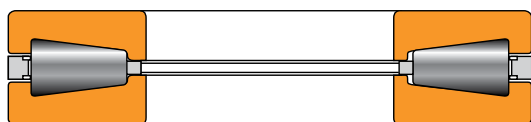

Fig. 21. TTHD.

TTHDFLSX and TTHDFLSV

Composition: Identical to the TTHD construction with a top ring generally made with convex outer face (TTHDFLSX). A concave (TTHDFLSV) top ring also can be supplied if needed.

Application: Screwdown thrust bearing.

Remarks: Full-complement design for maximum capacity. Lifting holes exist in each ring for handling purposes.

Both designs are also available with a tapered bottom race design (TTHDSX and TTHDSV).

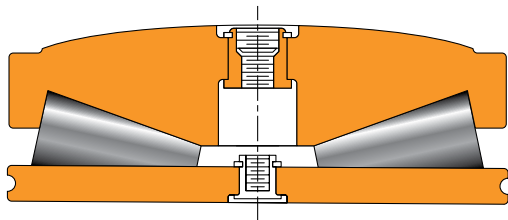

Fig. 22. TTHDFLSX.

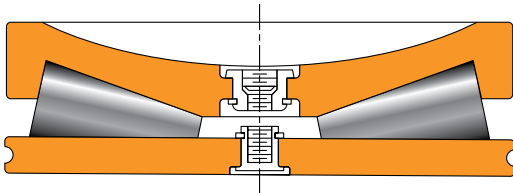

Fig. 23. TTHDFLSV.

SPHERICAL ROLLER THRUST BEARING

TSR

Composition: One single inner ring with spherical rollers with cage retainer and one single outer ring.

Application: Thrust position for gearboxes and auxiliary equipment.

Remarks: Type TSR spherical roller thrust bearings maintain a high-thrust capacity and accommodate misalignment.

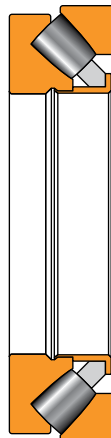

Fig. 24. TSR.

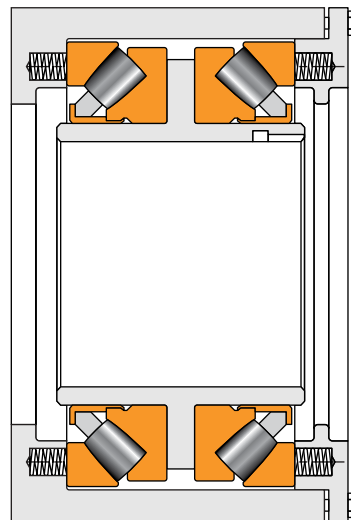

Fig. 25. TSR assembly.

2TSR assembly

Composition: Two single inner rings with spherical rollers and cage retainer installed in a sleeve and two single outer rings, all mounted in a carrier.

Application: Thrust position for gearboxes and auxiliary equipment.

Remarks: To maintain loading in the row unloaded by the axial load, the whole assembly is preloaded using springs mounted in the carrier.

AUXILIARY EQUIPMENT

Timken offers a wide range of bearings for auxiliary equipment applications such as gear drives, table rolls, coilers, end coilers, levelers, pinion stands, handling equipment and more.

TAPERED ROLLER BEARINGS

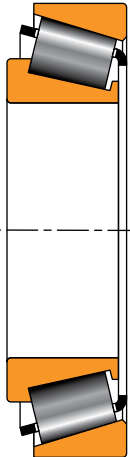

TS

Composition: One single cone with tapered roller and one single cup.

Application: Saws, guiding rolls, scrap choppers and small drives.

Remarks: The TS is the most common tapered roller bearing that allows the designer a large choice of mountings. TS bearings always are fitted in pairs, whether mounted directly like a TDI or indirectly like a TDO.

Fig. 26. TS.

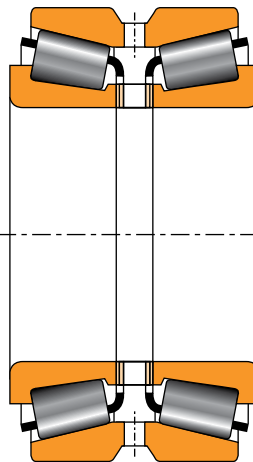

TDO

Composition: Two single cones, one double cup and one cone spacer.

Application: Mill drives, pinion stands, coilers, uncoilers, side trimmers and scrap choppers.

Remarks: The TDO is a preset assembly and works at fixed and floating positions on rotary shaft applications. Holes and circular grooves are normally provided on the double cup for lubrication

Fig. 28. TDO.

purposes, one counterbored hole is usually included. This permits the provision of a locking pin to keep the loose-mounted cup from rotating at the floating position. This is then referred to as a CD cup.

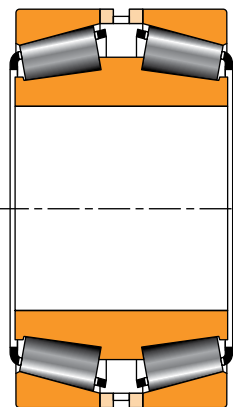

TDI AND TDIT

Composition: One double cone, two single cups, spacer or spacerless.

TDI version with straight bore (illustrated).

TDIT version with a tapered bore.

Application: Edgers, bar mills and rod mills. We suggest the tight-fitted TDIT assembly when mill speeds exceed 600 m/min. (2000 ft./min.).

Fig. 27. TDI and TDIT.

Remarks: TDI/TDIT bearings can be delivered as a preset assembly. The cups and cones are normally mounted loose on the top version. The bearing works at fixed positions on rotating shaft applications. For a rotating housing application, it can float on the stationary shaft.

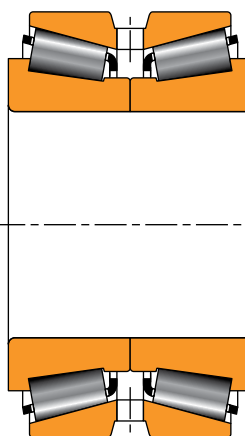

TNA AND TNAT

Composition: Similar to the TDO version. Inner cone small faces are extended to abut and eliminate the need for a spacer.

TNA version with straight bore (illustrated).

TNAT version with tapered cone bores.

Application: Mill drives, pinion stands, coilers and uncoilers.

Fig. 29. TNA and TNAT.

Remarks: Preset assembly. These bearings provide a solution for many fixed or floating bearing applications where simplicity of assembly is required.

SPHERICAL ROLLER BEARINGS

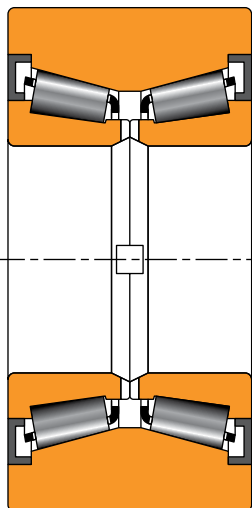

TNASWH

Composition: Same as the TNA bearing with one heavy section double cup and two closures.

Application: Levelers, chock wheels, conveyor car wheels, various railcars and crane sheaves.

Remarks: Preset assembly with profile cup. Cones mounted loose on the stationary shaft. Assembly also could function as a wheel.

Fig. 30. TNASWH.

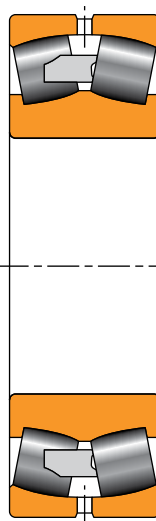

EM TYPE

Composition: One double inner ring, one double outer ring, two rows of spherical rollers with roller-riding brass cage(s).

Application: Mill drives, pinion stands, coilers and uncoilers.

Remarks: EM-type bearings manage high radial loads when shaft deflection is important.

Fig. 31. EM type.

⚠ WARNING
Failure to observe the following warnings could create a risk of death or serious injury.

Never spin a bearing with compressed air.
 The components may be forcefully expelled.

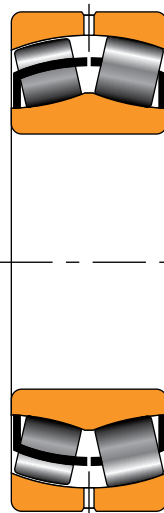

EJ TYPE

Composition: One double inner ring, one double outer ring and two rows of spherical rollers with stamped-steel cages.

Application: Gear drives, table rolls and auxiliary equipment.

Remarks: EJ-type spherical roller bearings feature a hardened stamped steel window-type cage with face slots for improved lubrication flow. It offers high load ratings for longer life.

Fig. 32. EJ type.

CYLINDRICAL ROLLER BEARINGS

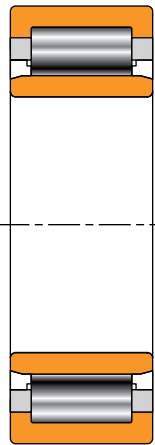

ONE-ROW EMA TYPE

Composition: One single inner ring, one single outer ring, one row of cylindrical rollers with a one piece, land-riding window-type brass cage.

Application: Gear drives, electric motors.

Remarks: Available in multiple configurations: NU, N, NJ, NF and more.

Fig. 33. One-row EMA type.

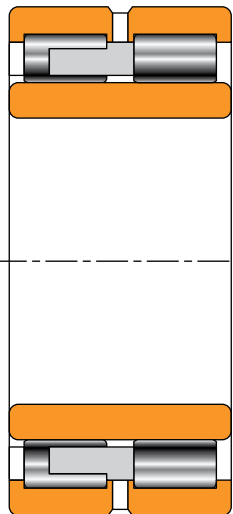

TWO-ROW CYLINDRICAL ROLLER BEARINGS

Composition: One single inner ring, one single outer ring, two rows of cylindrical rollers with a one piece, land-riding, finger-type brass cage.

Application: Gear drives, crop shear.

Remarks: Standard cage design includes a drilled pocket, finger-style brass retainer.

Fig. 34. Two-row cylindrical roller bearings.

BALL BEARINGS

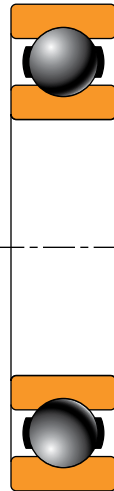

DEEP-GROOVE RADIAL BALL BEARING

Composition: Inner and outer ring with a cage containing a complement of balls.

Application: Gear drives, electric motors, fly wheels and auxiliary equipment.

Remarks: The standard deep-groove construction handles radial and light axial loads for moderate- to high-speed applications. Available in multiple configurations.

Fig. 35. Deep-groove radial ball bearing.



ANGULAR-CONTACT BALL BEARING

Composition: Inner and outer ring with a cage containing a complement of balls.

Application: Work roll thrust position for long product mill. Auxiliary equipment.

Remarks: Designed for combination radial and axial loading. Single-row bearings have thrust capacity in one direction. Typically used in pairs to accommodate thrust in both directions.

Fig. 36. Angular-contact ball bearing.

APPLICATION CONSIDERATIONS AND BEARING SELECTION

The following processes are covered in this section:

- Steelmaking.
- Continuous casting.
- Rolling mill.
 - Flat product rolling.
 - Long product rolling.
- Bearing solutions: radial positions.
 - Work and intermediate rolls: flat product mills.
 - Work rolls: long product mills.
 - Backup rolls.
- Bearing solutions: axial positions.
- Auxiliary equipment.
 - Main mill drive and pinion stand gearboxes.
 - Pay-off and rewind reels.
 - Shears and shear drives.
 - Table rolls.

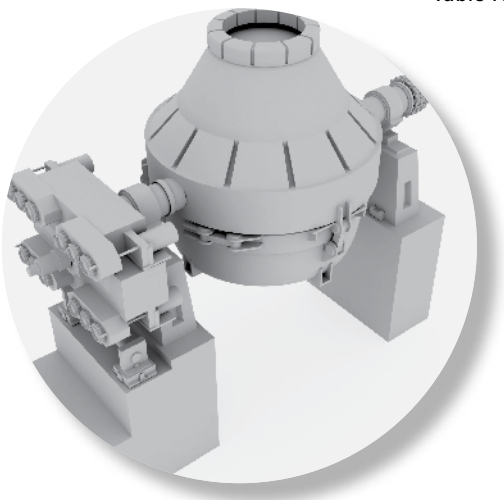
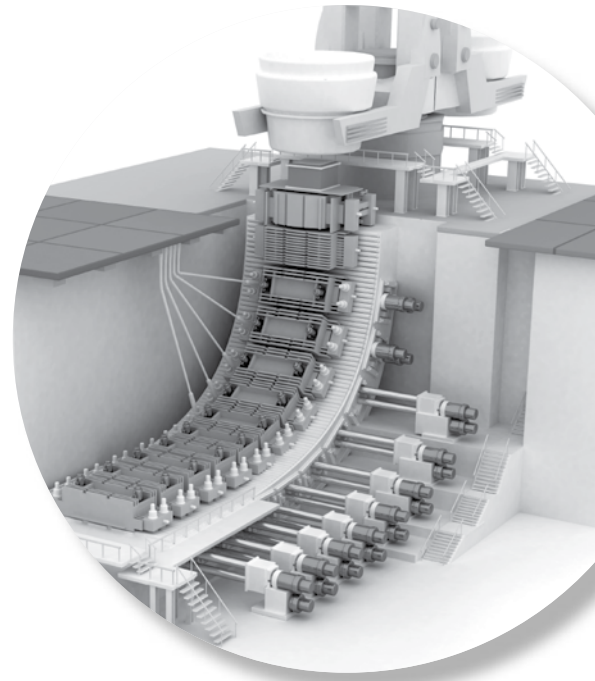

The basic processes for the production of semi-finished and finished products includes the following stages: mining the ore, smelting, alloying, casting, rolling and finishing. Depending on the metal type and production method, the processes used during the smelting stage, where the metal is extracted from the ore, can vary dramatically. After the smelting stage, the processes for metals production have much more in common.

This section outlines the critical bearing applications used in the metals production process after the smelting stage. Specifically, it covers applications in basic oxygen furnaces (BOF) and continuous casters used in steel production, as well as hot-rolling and cold-rolling mills that can be used in the production of flat and long metal products.

STEELMAKING

THE BASIC OXYGEN FURNACE

In the BOF (fig. 37) and the mechanically similar bottom-blown oxygen process (BBOP) and argon-oxygen decarburization (AOD) furnace, steel is melted for final alloy adjustment and purification. The three furnaces are all types of converters. Each type has its own configuration but they all are generally comprised of the following equipment:

- **Furnace vessel.** The furnace vessel usually resembles a barrel-shape with a dished bottom and a conical top. The inside includes a refractory material lining and a retractable hood that closes off the top of the conical section.
- **Trunnion ring.** A trunnion ring wraps around and supports the vessel. The trunnion ring allows the vessel to tip back and forth, pivoting on two stub shafts about 180 degrees apart.

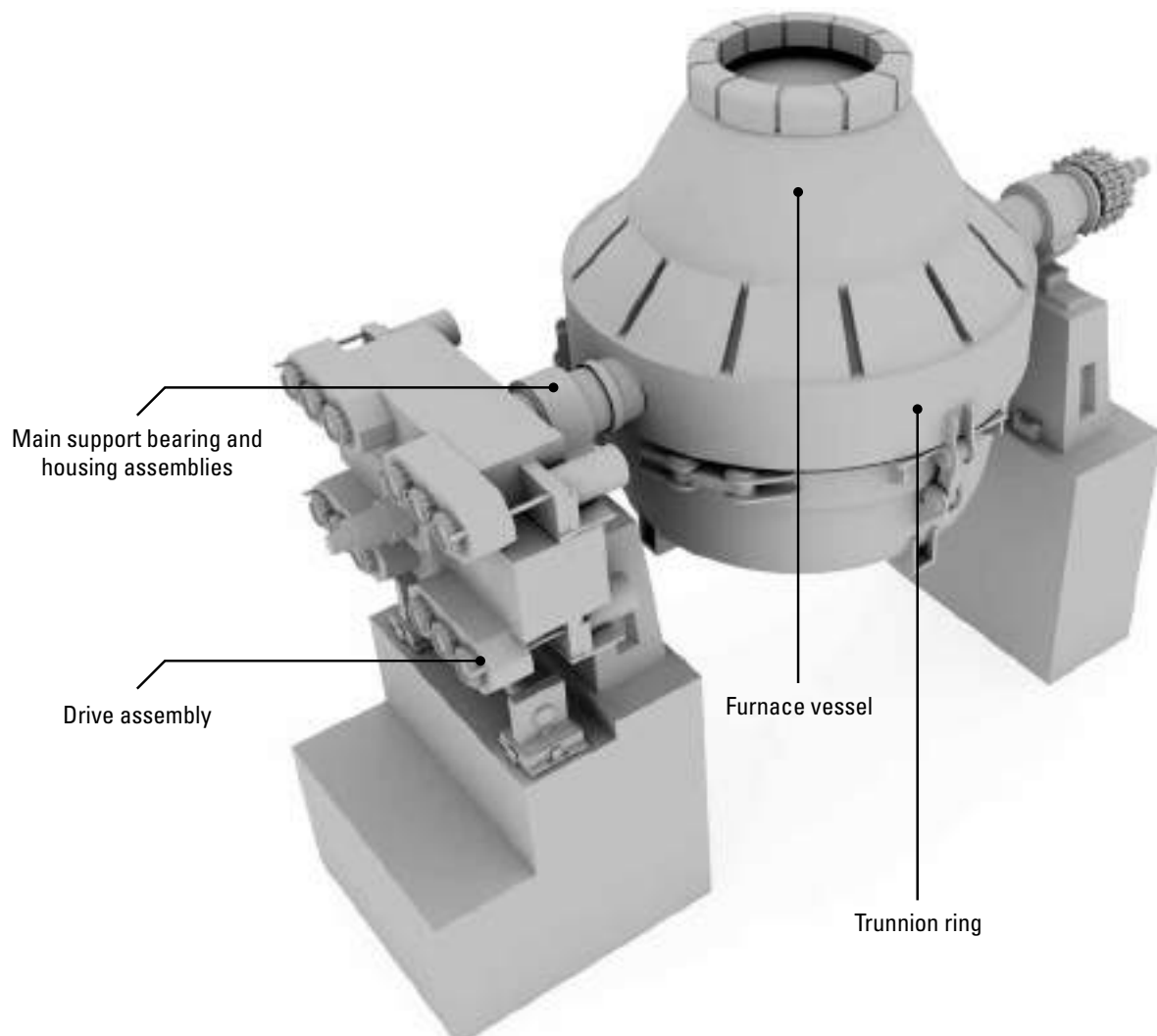

Fig. 37. Basic oxygen furnace.

- **Main support bearings and housing assemblies.** These bearings come mounted to the stub shafts on the trunnion ring and support the entire weight of the loaded furnace and its drive.
- **Drive assembly.** The drive assembly rotates the vessel forward and backward from the vertical position through approximately 135 degrees in each direction. In modern vessels, a trunnion stub shaft supports the drive and a torque arm anchors it to the foundations.

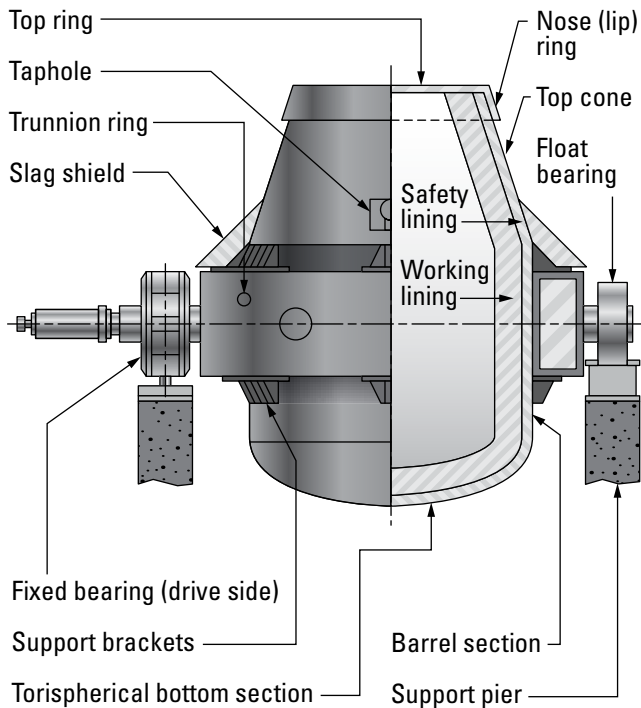

Fig. 38. Bearing support on basic oxygen furnace.

There are two key positions for roller bearings in BOF applications. The first and most challenging include the two main support positions for the vessel and its trunnion ring (fig. 38). The second lies within the drive.

The main support position bearings allow the vessel to tip forward for raw material loading and for pouring out the refined steel. The vessel tips backwards after the refined steel is poured off (teemed) for slag removal. The melting completes with the vessel in the vertical position. The combined weight of the vessel, trunnion ring and the melt may exceed 1000 metric tons. In modern designs, where the drive mounts directly to the trunnion support shaft rather than to the foundation, the loads can approach 1500 metric tons.

The second key bearing locations exist within the drive for the BOF rotation. The drive is generally comprised of several smaller enclosed gear reducers and motors mounted to a common gear case that also enclose the bull gear. Each of the smaller drive units has its own pinion that meshes with the bull gear. Bearing selection for this application follows traditional power transmission guidelines.

MAIN SUPPORT POSITIONS

The preferred bearing type for main support trunnion positions is the spherical roller bearing due to its high-radial capacity, ability to function as a fixed position bearing and high-misalignment capability. Bearing selection is based primarily on static load capacity because of the slow rotational speed. The target static capacity-to-load ratio is 3:1 or greater. Typical sizes fall in the range of 600 mm (23.62 in.) bore to 900 mm (35.43 in.) bore but go as high as 1250 mm (49.21 in.).

We also must consider when establishing the bearing requirements unique application conditions. These conditions may include:

- Structural deflections that may exceed ± 1.5 degrees.
- Very high loads at very low speeds and elevated temperatures. This is particularly important in relation to lubrication.
- Oscillating motion through a maximum of 270 degrees of rotation.
- Significant axial growth of the trunnion ring due to temperature changes over a large bearing spread up to 12 m (40 ft.).
- Significant vibration from the agitation of the steel during melting and from blowing oxygen through the liquid steel. Vibration is particularly extreme in AOD furnaces.
- Highly contaminated operating environments and the resulting demanding sealing requirements.
- Practical accessibility for inspection and future bearing replacement.

For these applications and operating conditions, Timken suggests using a complete bearing and housing system that is tailored to the specific installation. This system generally includes two housed assemblies – one for the float position and one for the fixed position.

BOF trunnion float position

The float position assembly (fig. 39) generally mounts on the non-driven side of the vessel and must accommodate several centimeters (inches) of axial movement. The typical bearing solution mounts the support bearing in a cartridge supported on a pair of inclined linear bearings, often referred to as ladder bearings (fig. 40).

The ladder bearings typically offer a float capability of ± 60 to 100 mm (2.5 to 4.0 in.) from its centered position. The static load capacity of each ladder bearing approximately equals that of the main support bearing.

FLOAT SIDE OF BOF HOUSING ASSEMBLY:

Positive lubrication through center of bearing.

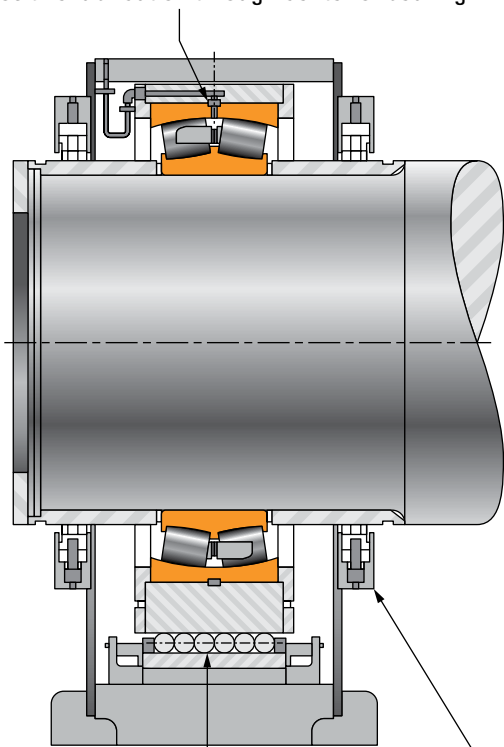

Bearing cartridge floats on ladder bearing to accommodate thermal expansion.

Complete assembly installed as a unit; all bearing areas completely sealed.

Fig. 39. Float side of BOF housing assembly.

This design does not require the float bearing to move axially in its housing. This eliminates the risk of galling and wear that can occur on the bore or outer diameter surfaces when high radial load forces the bearing to move. Ladder bearings are inclined towards each other in a shallow V configuration to stabilize and locate the cartridge in a crosswise direction.

The main support bearing generally has a loose fit on the trunnion shaft and in the cartridge to facilitate installation and removal. The floating cartridge assembly and ladder bearings mount in a fully enclosed steel housing that also includes the main seals.

Full ring to contain radial bearing.

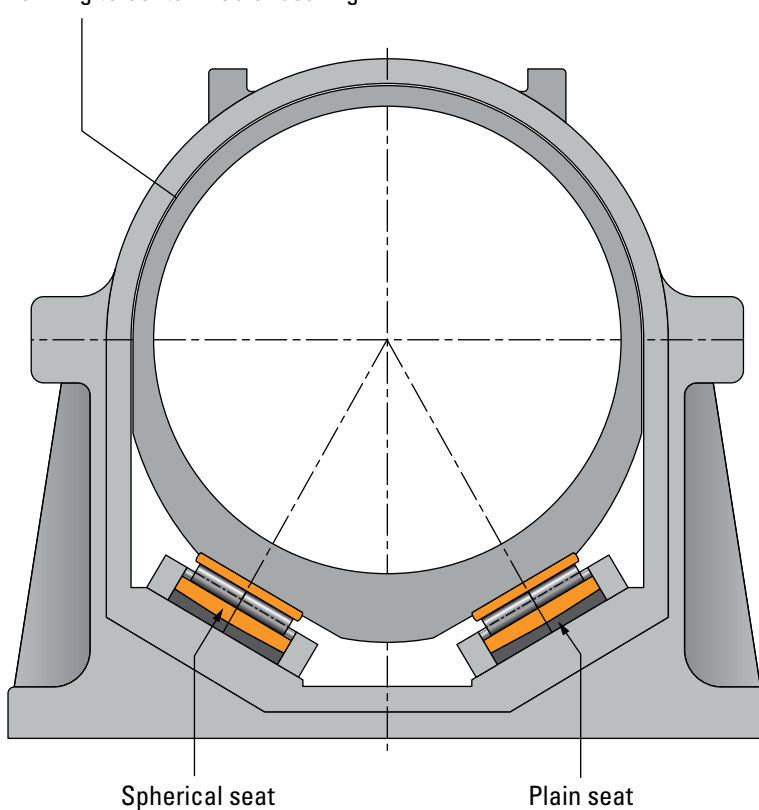

Spherical seat

Plain seat

Fig. 40. Ladder bearing arrangement.

BOF trunnion fixed position assembly

The fixed position assembly is simpler and smaller because it does not require the floating internal cartridge or ladder bearings. The fixed position is usually on the drive side of the furnace. One important design feature of the fixed position assembly involves the ability to replace the original standard bearing (fig. 41) with a split version (fig. 42). This proves necessary because the replacement of a standard bearing would require the removal of the complete drive assembly. This is a difficult and very time-consuming task.

Initial mounting of standard bearing is done in one of two ways. Either mount a straight bore bearing directly to the shaft using a tight fit; or mount a tapered bore bearing using a tapered adapter.

The use of the adapter allows final control of the bearing position on the shaft and some adjustment of the bearing internal clearance. The adapter also facilitates bearing removal through the use of hydraulic pressure that frees the bearing from the adapter.

FIXED SIDE OF BOF HOUSING ASSEMBLY:

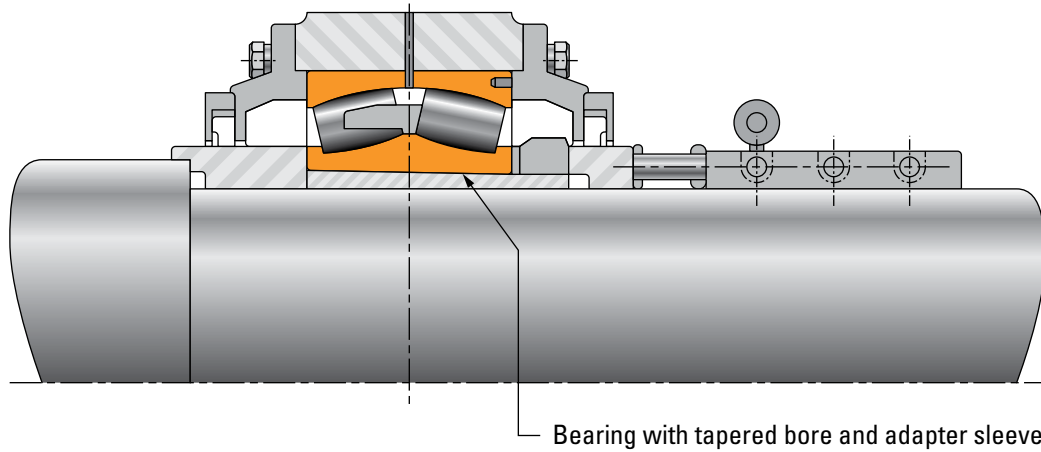

Fig. 41. Standard bearing.

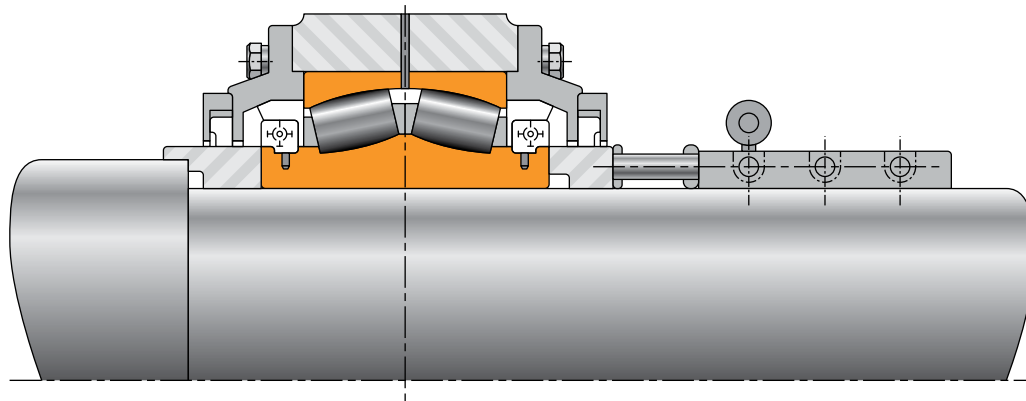

Fig. 42. Split bearing.

The use of a split replacement bearing facilitates removal of the standard bearing. First remove the housing cap, slightly raise the trunnion shaft, then remove the standard bearing by cutting or fracturing it into halves. If a tapered adapter was used, remove it in the same manner. An axial slot in the adapter-bore facilitates burn off without trunnion shaft damage. The new split bearing builds up around the shaft before lowering back down into the housing.

The tight-fitted adapter helps reduce the risk of impact damage to the bearing components due to potentially violent vibration of the vessel during operation.

Spherical roller bearings used in BOF housings have a standard misalignment capability of 1.5 degrees. When higher misalignment is required, the bearing may be supplied with a wide outer ring that increases the misalignment capability to 3 degrees. Timken identifies bearings with this feature using W57 in the part number.

Timken usually supplies assemblies with sleeves located on the trunnion shaft on both sides of the bearing. The backing sleeves facilitate axial clamping of the complete assembly onto the shaft and function as seal riding surfaces. When installing a split bearing, replace these sleeves with narrower versions to make room for the wider inner ring.

Because BOF bearing assemblies must function in the dust-contaminated and often hot environment of a steel mill, effective sealing is critical. Bearings subjected to contamination by abrasive converter dust may suffer premature wear. To help prevent this, robust sealing accommodates the displacement of the shaft that results from trunnion ring thermal growth and deflection.

Additional considerations for trunnion bearing selection

Furnaces must tolerate the significant and sometimes violent vibration that occurs during furnace charging, melting and purification. Consider these factors during the design and selection of bearings and housings. For optimal bearing performance, we prefer light-to-tight bearing fits on the shaft and in the housing. However, it also is important to consider the ease of installation and removal.

Minimized bearing radial clearance limits risks of fretting corrosion (false brinelling) of the rollers and raceways. Minimizing operating clearances and applying light-to-tight fits also improves the seating of the bearing's inner and outer rings and maximizes the load zone within the bearing. These bearings are traditionally through-hardened but Timken also offers the bearings with case-carburized components for applications where shock loading is a particular concern.

In this application, the lubricant primarily functions to help prevent corrosion and to help keep contaminants out. To achieve this, we suggest 100 percent grease fill of the bearing and housing cavity. These furnaces use an extremely slow rotational speed. Rollers and raceways cannot generate a normal lubricant film. A heavy consistency, extreme-pressure (EP) grease with a very high base-oil viscosity can improve lubrication conditions. We suggest synthetic base oil, lithium complex types.

Timken also manufactures split and special bearing designs and can review your specific application needs. For more details, contact your Timken engineer.

CONTINUOUS CASTING

The continuous caster for producing steel slabs (fig. 43), blooms and billets represents the most significant development in steel production since the Bessemer converter. Compared to the traditional, individually poured cast ingot route, the continuous caster offers significant improvements in yield, consistency and energy efficiency as well as reduced emissions and waste products. In addition, the ability to cast thinner slabs (alloy dependent) may significantly reduce the subsequent hot rolling requirements.

Generally, the conventional slab caster produces slabs between 180 mm (7 in.) and 300 mm (12 in.) thick at speeds of 0.8 to 2.0 m/min. (2.6 to 6.5 ft./min.). The medium slab caster produces slabs between 100 mm and 180 mm (4 and 7 in.) thick at speeds of 1.0 to 3.0 m/min. (3.3 to 10 ft./min.). The thin slab caster produces slabs less than 100 mm thick at speeds of 3.0 up to 6.0 m/min. (10 to 20 ft./min.).

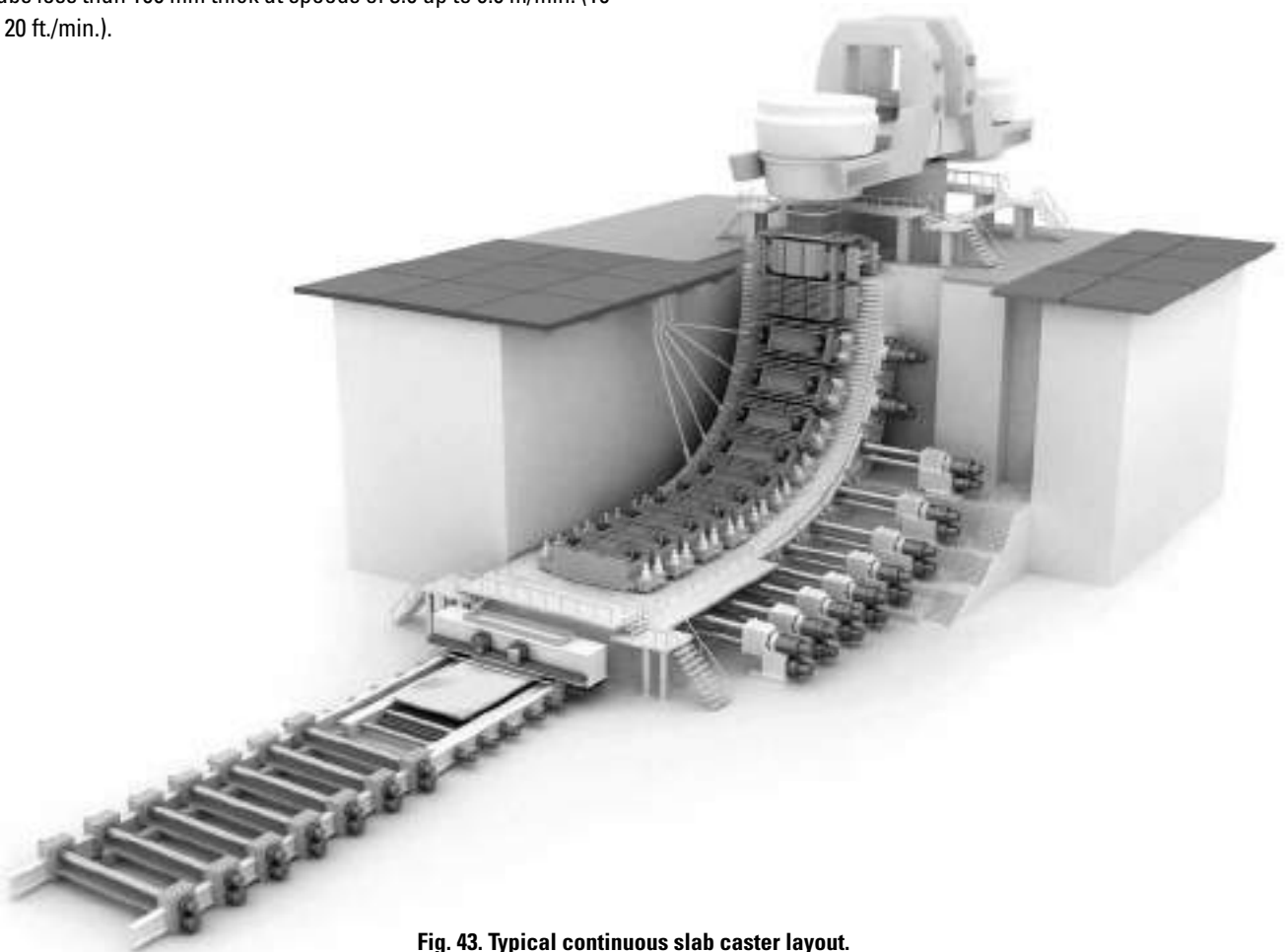

Fig. 43. Typical continuous slab caster layout.

CASTER DESIGN

Fig. 44 shows the main components of the continuous caster. Nearly all installations possess this overall configuration, although minor variations will exist depending on the original equipment manufacturer's technology, steel grade being cast, and end-user preferences.

The following description refers to slab casting but bloom and billet casters can receive similar considerations.

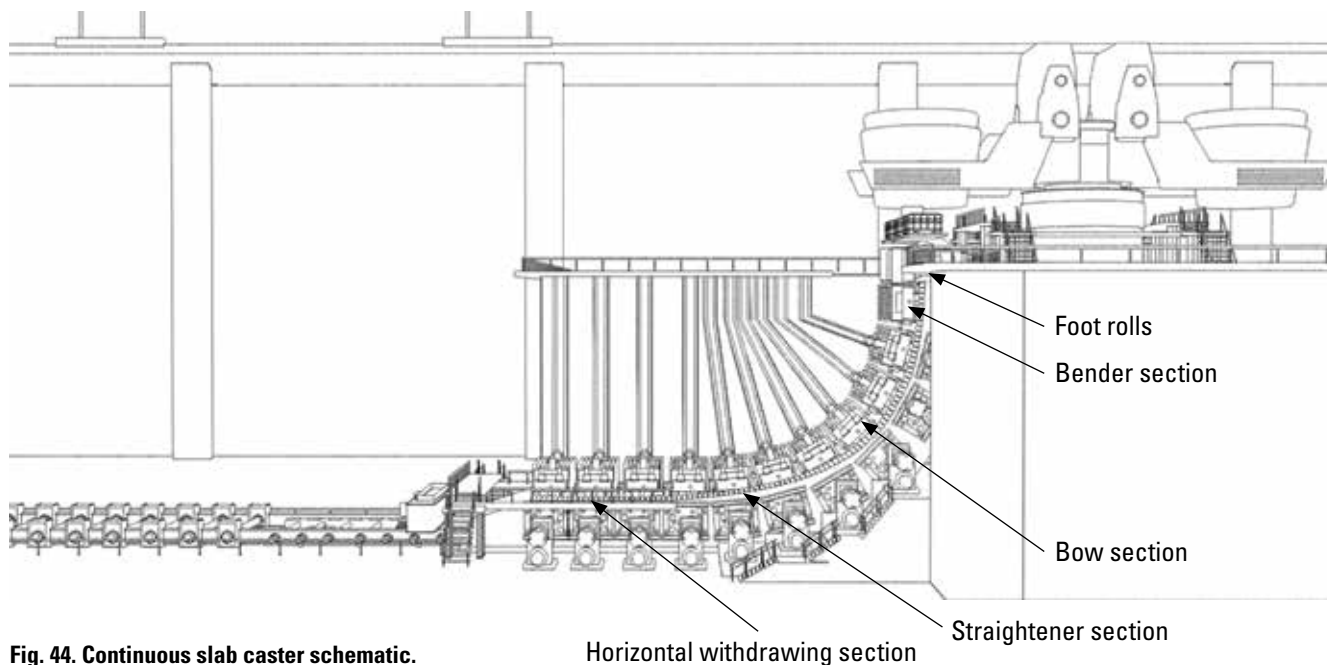

Fig. 44. Continuous slab caster schematic.

SEQUENCE OF OPERATIONS

First, molten steel transfers from the steelmaking furnace to the casting platform in a ladle.

Then the ladle pours the molten steel into the tundish through a shroud.

Another shroud takes the molten steel into the water-cooled mold. The mold lining, typically comprised of a copper alloy, oscillates to minimize the chance of the steel sticking to the mold. The steel solidifies at the surface to form its shape (slab, billet or bloom) before it emerges from the mold, attached to the dummy bar. The dummy bar detaches at the exit end of the caster.

Once the slab leaves the mold, it proceeds through the top zone (foot rolls) via the bender to the curved (bow) section through a straightener section and finally to the horizontal withdrawal section.

A straight-mold equipped caster includes a bender section that forms the slab to match the curvature of the bow section. Casters with a curved mold do not require the bender.

Below the mold, caster sections break down into eight to 12 discrete segments, each with five to seven roll pairs with one roll of each pair above and one below the slab. One of the roll pairs is a driven pair that controls the speed of the slab. The other, idler rolls, support the slab and maintain its thickness and shape. Many casters will make a small reduction in the slab thickness as it descends through the bow section. This is referred to as soft core reduction and is done for metallurgical reasons rather than for slab thickness control.

The top and bottom rolls are mounted on two separate frames and adjustment is provided to allow setting the position of the top rolls relative to the bottom rolls. Each of the individual roll segments can be removed from the caster as a complete assembly.

External, high-volume water sprays cool the slab. The support rolls also are water cooled via rotary couplings and internal passages. Cooling the rolls and bearing housings controls component temperature and the integrity of their mechanical properties.

After the slab exits the straightener segment(s) it passes through the horizontal withdrawal segments and is cut to length with a traversing gas torch. Finally, the slab is brought to a cooling yard where it is marked before being transferred to the hot rolling mill.

CASTER BEARING POSITIONS

LADLE TURRET

The rotating portion of the turret, supports the main bearing application in the ladle turret.

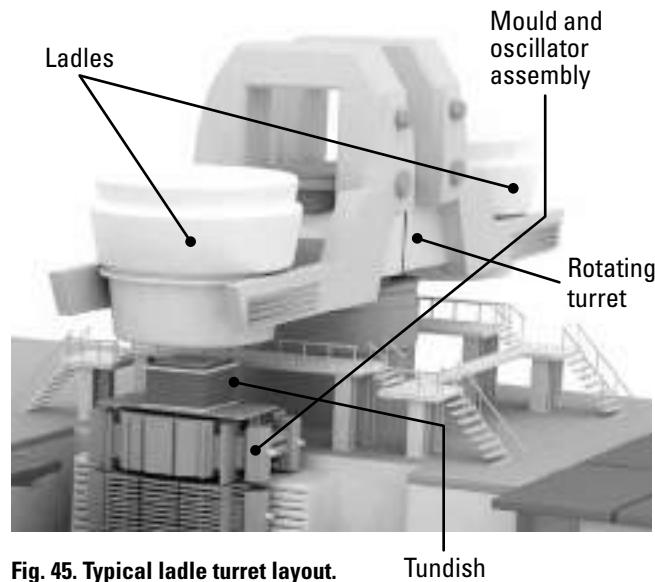

Fig. 45. Typical ladle turret layout.

Ladle turret bearings

The bearings must resist very high overturning moments resulting from the cantilevered loads. The highest overturning moments occur when one side supports a full ladle while the other side is empty. They also must tolerate shock loads that occur when a full ladle is loaded onto the support arms. The total weight of the ladle turret, ladles and molten steel can exceed 1000 metric tons, while the rotational speed reaches no more than 1 rev./min.

Two turret design styles exist. The first (fig. 45) uses a single turntable attached to both support arms. The turntable is mounted onto a large-diameter slewing ring bearing that can measure several meters in diameter. This is the most common design.

The second design utilizes a central column, or mast, around which sleeve-attached support arms rotate around the center column on radial and thrust bearings. This style can be configured to accommodate independent rotation of each ladle support arm.

Bearing types used in the mast-style ladle turret will vary according to the original equipment manufacturer. Generally, cylindrical roller bearings provide radial support and a dedicated thrust bearing provides the axial support. This thrust bearing can utilize a tapered-, spherical- or cylindrical-roller type.

MOLD OSCILLATOR

Oscillating the mold is critical to help minimize the sticking of the steel to the mold liner. Early caster styles achieved this oscillation through mechanical mechanisms using cams or eccentrics and an electric motor drive. Hydraulic resonant oscillators replaced most of these designs because they provide a more compact design and control flexibility. The hydraulic design also eliminates mechanical drive components that can wear quickly and require frequent maintenance.

Mold oscillator bearings

Casters that use mechanical oscillators require bearings specifically designed to handle the oscillating loads and vibrations. Cylindrical, spherical and tapered roller bearings commonly meet this need. They are generally specified with high-strength cages and are manufactured with tight control of internal clearances and run-out.

FOOT ROLL (TOP ZONE) AND BENDER SECTIONS

This is the first section of slab support rollers directly beneath the mold. The skin on the slab is thin and fragile so the support rollers are close together and small in diameter. These rolls are usually in the range of 120 to 160 mm (4.7 to 6.3 in.) in diameter and are idler (non-driven) rolls.

Roll construction utilizes a single, full-width arbor/axle built up with roll section sleeves and intermediate support bearings. More commonly, roll construction consists of individual roll sections, each with a support bearing at both ends. These rolls utilize external cooling with water sprays.

Caster bearings endure tough conditions in this environment, including heavy loads, high temperatures, low rotational speed as well as water, scale and steam contamination. The slab surface, which passes just a few millimeters (a fraction of an inch) from the bearing housing, reaches approximately 1000° C (2000° F).

Foot roll section and bender bearings

Due to these extreme conditions, bearings located at foot roll (fig. 46) and bender roll positions are usually removed from operation on a fixed schedule rather than on the basis of their condition at inspection. Replacement typically occurs every four to six months.

Sealing is usually achieved with the use of steel spiral rings or piston rings since the temperatures are too high for elastomeric seals. A continuous grease lubrication is typically used to keep contaminants from entering into the bearing.

Bearing types used here include single- and double-row needle roller bearings in the NA49, NA59 and NA69 series, as well as spherical roller bearings and cylindrical roller bearings of the toroidal or self-aligning type. Our specially heat-treated bearings offer dimensional stability during operation at elevated temperatures. These bearings are usually identified with a S2 or S3 as the suffix to the part number. This identifies the bearings as being dimensionally stable at temperatures up to 250° C and 300° C (482° F and 572° F) respectively.

Bearing loads in these applications vary by the number of rolls, the number of bearings per roll, roll position and the ferro-static pressure within the slab. Speeds often fall in the range of 2 to 15 RPM, depending on the thickness of slab being cast. The low rotational speed means that loading is considered static because a hydrodynamic lubricant film generates outside the rollers and the raceways of the bearing. The bearing's static capacity is, therefore, more important than the dynamic capacity. Generally, bearing selection revolves around a static capacity-to-load ratio of 3:1. However, the frequent replacement of the bearings means that many installations operate with a ratio of 2:1. This need for frequent maintenance, combined with low speeds prompt loose fits for both the inner and outer rings.

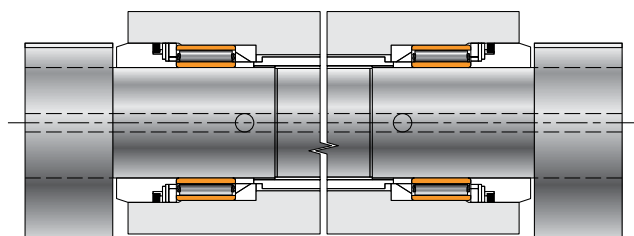

Fig. 46. Typical foot roll bearing arrangement.

SLAB SUPPORT SEGMENTS (BOW, STRAIGHTENER AND HORIZONTAL SECTIONS)

The slab support segments in the bow, straightener and horizontal sections of the caster all possess similar configurations, but with variations in the number of rolls and the roll diameters. Segment configuration provides for easy removal and replacement as complete assemblies.

The shell of the slab gets thicker as the slab moves down the caster, with complete solidification occurring somewhere in the lower half of the bow section. This means that the slab support rollers can be placed further apart and can be larger in diameter than those at the top of the caster. The number of rolls in each segment varies from 10 to 14, arranged in pairs, with one roll of each pair above and one beneath the slab.

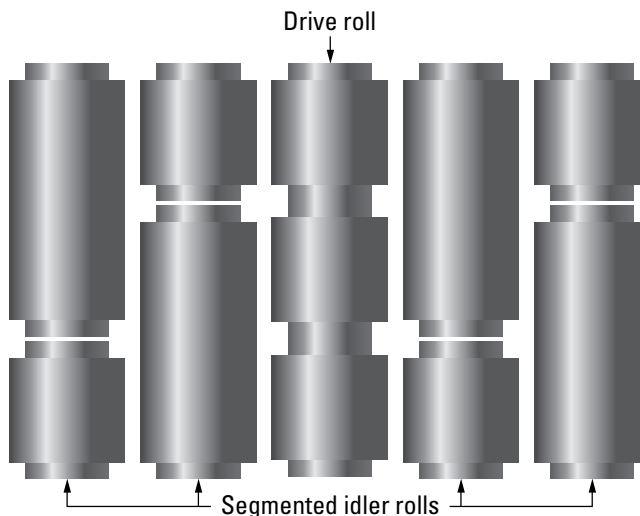

Fig. 47. Typical roll configuration.

Generally, the center pair of rolls drives and controls the speed of the slab through the caster (fig. 47). The remaining rolls are idler rolls. The loading on the segment rolls in slab casters requires intermediate support bearings along their lengths to minimize the roll deflection. Slab quality demands this key parameter.

The idler support rolls often include two or three short roll sections with each section having a bearing at either end. These rolls utilize internal cooling and use rotary couplings to bring the cooling water to and from the rolls.

Staggered positions of the intermediate bearings fall in the direction of material travel. This minimizes the effects to the unsupported portion of the slab where it passes over the bearings and housings.

Slab support segment bearings

Bearing selection and mounting must allow for one fixed and one or more float positions for each roll section. The spherical roller bearing usually achieves the fixed position selection.

The float position bearings must accommodate up to 6 mm (0.25 in.) of roll thermal-axial growth and up to 0.5 degrees misalignment. Float position solutions include self-aligning cylindrical bearings, toroidal roller bearings or Timken® ADAPT™ bearings (fig. 48) that combine the characteristics of both spherical and cylindrical roller bearings. These designs will accept axial float within the bearing as well as higher misalignment than a standard cylindrical bearing.

The spherical roller bearing also applies at the float position, but in this case, loose fits are employed for the outer ring to accommodate float in their housings.

Casters may use idler rolls that use a single, full-width arbor (shaft) and roll section sleeves. We may refer to this style as a stacked-arbor design (fig. 49). This stacked-arbor style uses a single bearing in the intermediate support position that reduces the width of an unsupported slab compared to the two bearings required with completely separate roll sections.

The bearing installation will usually follow standard fitting practice guidelines. Avoid heavy-duty tight fits because they complicate installation and removal and increase the risk of damaging the bearing during removal. In the case of spherical roller bearings, use C3 and C4 prevalent radial internal clearance.

We suggest G6 shaft fit for conventional (non-split) bearings and G7 or H7 for housing.

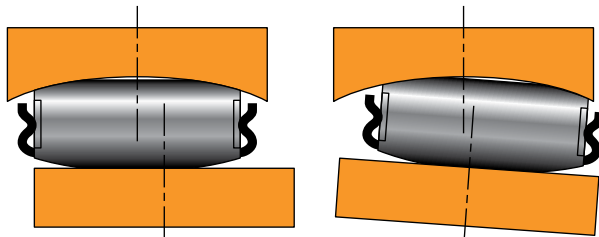

Fig. 48. The design of the ADAPT™ bearing allows for simultaneous axial float and misalignment. The rollers align with the inner ring regardless of axial displacement and misalignment.

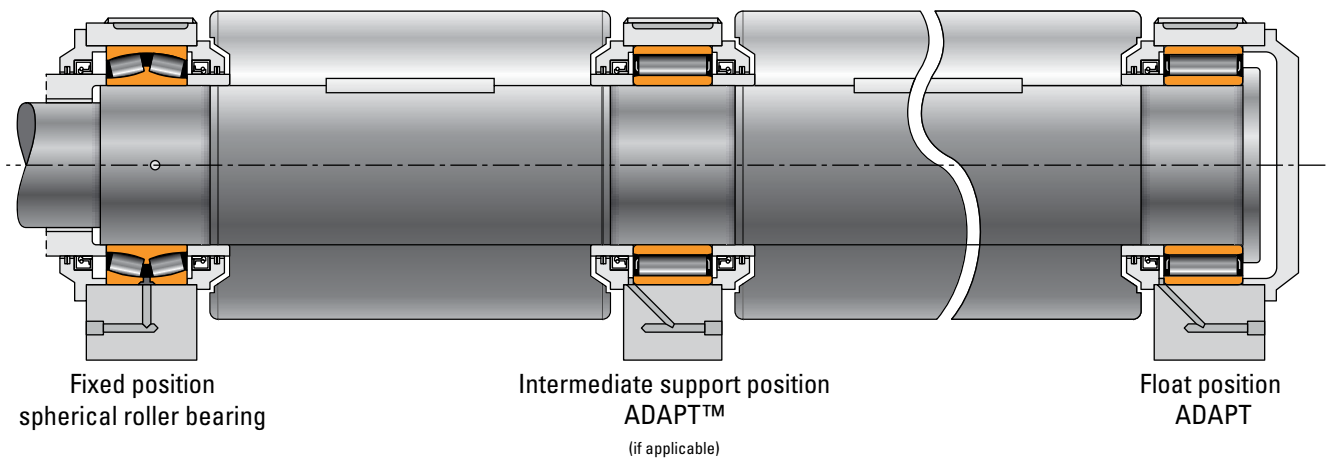

Fig. 49. Stacked arbor schematic with ADAPT bearing.

APPLICATION CONSIDERATIONS AND BEARING SELECTION

CONTINUOUS CASTING

The drive roll needs the intermediate support bearing(s) and needs to transmit drive torque across the full width. The traditional design achieves this with a one-piece roll with split bearings located at one or two positions (fig. 50). The bearing and housing assembly used in a one-piece roll design are split for mounting purposes.

These split bearing assemblies can utilize either spherical (fig. 51) or cylindrical roller bearing assemblies.

Split assemblies are usually designed as a complete system with the bearing and housing designed together to suit a particular caster roll configuration. Special bearings are required that do not conform to International Standard Organization (ISO) envelope dimensions or tolerances. Spherical assemblies require a loose shaft fit to allow axial float of the shaft. Cylindrical assemblies can use a transition fit on the shaft. Use loose housing fits for both the cylindrical and spherical roller bearing assemblies.

These assemblies must utilize split elements, including the bearing inner and outer rings, cages (when used), seals and the housing itself. Just like the conventional bearings and one-piece housings used in the end positions, the assemblies used here must also allow for water cooling of the housing caps and grease supply to the bearing.

Common key features to both spherical and cylindrical roller bearing types include the half outer ring, water-cooled housing cap and triple or double sealing elements. Timken uses a patented serpentine cooling chamber (fig. 52) in the cap to optimize the coolant velocity for maximum heat removal and minimum scale build up.

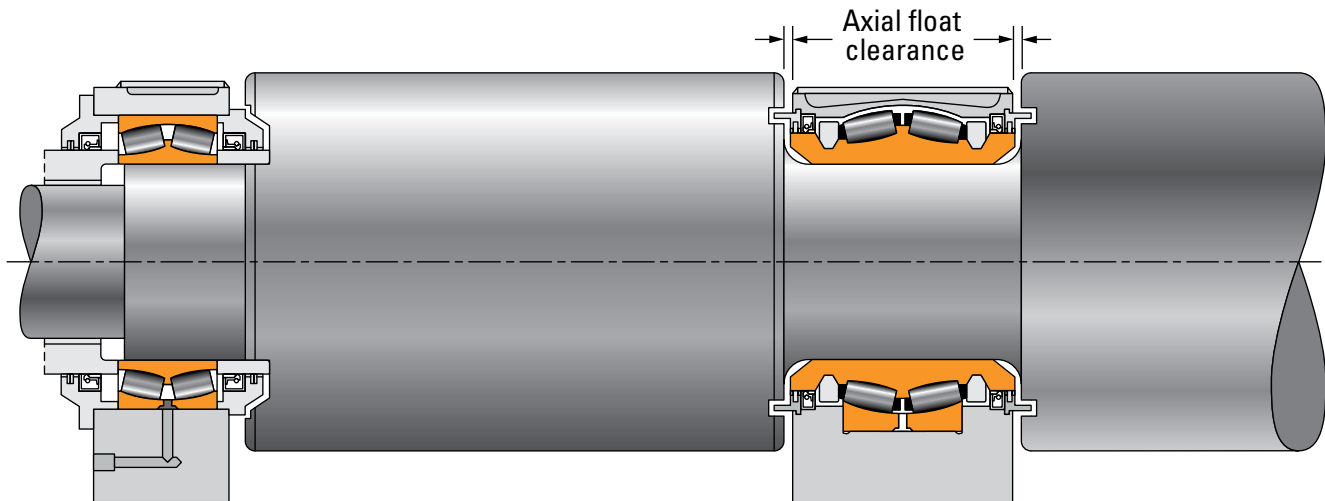

Fig. 50. Solid drive roll with split intermediate bearing.



Fig. 51. Split spherical roller bearing and water-cooled housing.

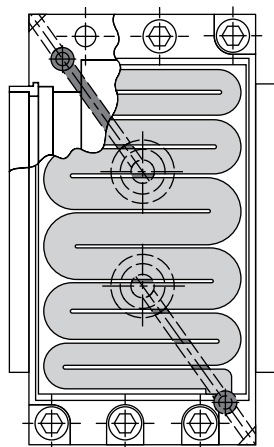

Fig. 52. Patented serpentine cooling chamber.

ROLLING MILL

FLAT PRODUCT ROLLING

While there will be variations to the product flow resulting in cold rolled strip, the process flow generally begins with material that either comes from a continuous caster, slabbing mill or directly from an ingot. In this section, we focus on the bearings and their relationship to the rolls they support (fig. 53).

The rolling mill is an extremely demanding application for bearings, which must perform under high operating temperatures, loads up to 8000 metric tons for the heaviest plate mills, and linear speeds in excess of 2000 m/min. (6500 ft./min.) for the fastest cold mills.

In addition, instantaneous changes in speed and direction can create punishing combinations of radial and thrust loads. When choosing a bearing for your rolling mill application, you must consider all operating parameters.

Several significant differences exist between hot rolling and cold rolling:

- Mill speeds are significantly higher in cold rolling than hot rolling.
- The strip exiting the cold mill is controlled to much tighter tolerances and higher surface quality.
- The cold mill will typically have extended run times during operation relative to the hot mill, particularly when the design of the mill calls for continuous operation, where coil ends are joined together upstream; or in foil mills, where final passes through the mill may last several hours.

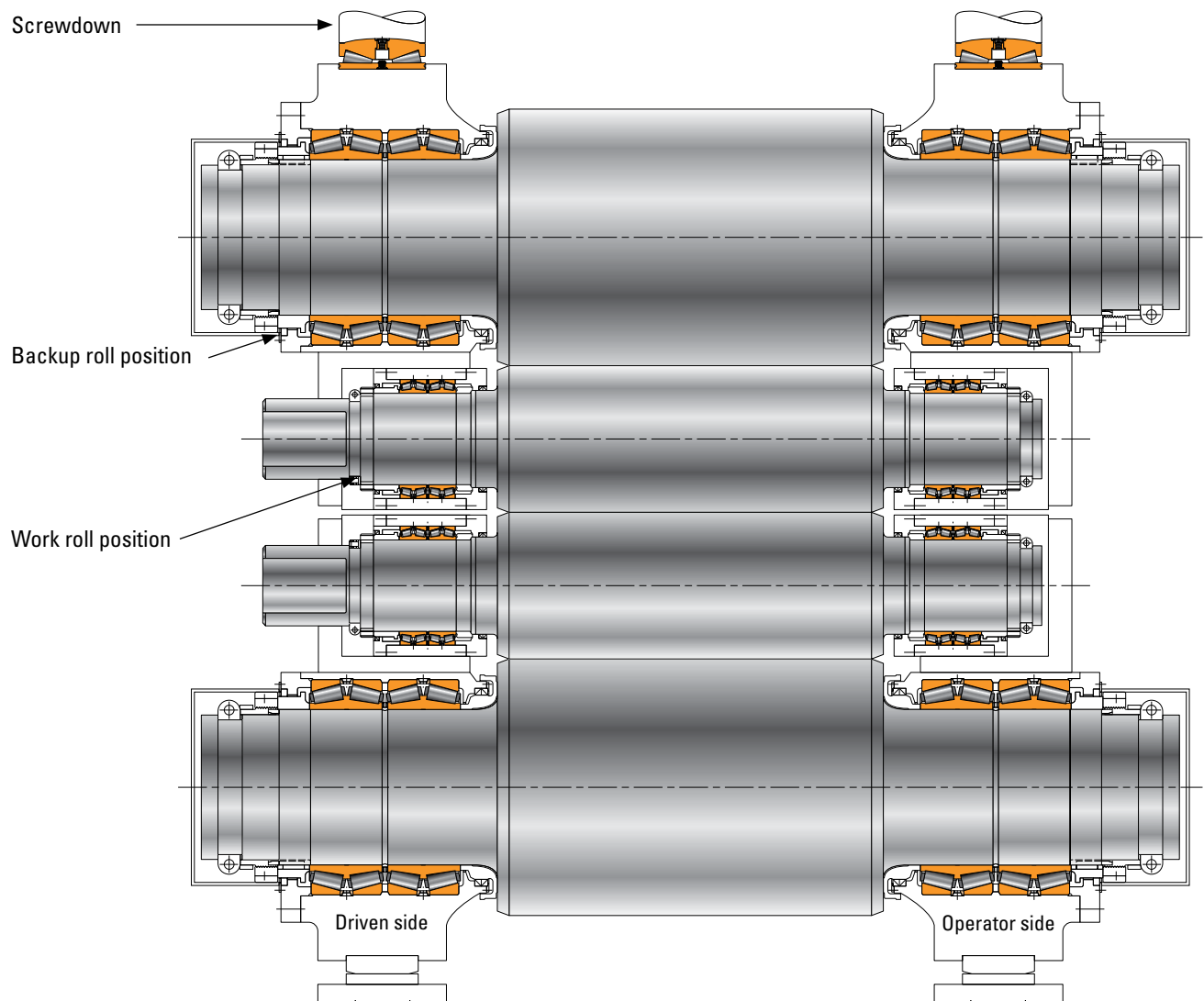

Fig. 53. Rolling mill applications 4-Hi mill stand.

PLATE MILL AND HOT MILL ROUGHING STANDS

Roughing stands are used for rolling heavy slabs supplied from a slabbing mill, continuous caster or sometimes rolled directly from an ingot. Finished material thickness varies greatly in dimensions. Mills can roll plates above 200 mm (8 in.) thick, 5 m (197 in.) wide, and 35 m (115 ft.) long. These three dimensions are determined by the slab or ingot weight as well as the rolling mill's size.

Mill speed: less than 300 m/min. (1000 ft./min.)

Roll neck bearings:

- **Backup roll radial position:**
TQOW, 2TDIW, multi-row cylindrical (RX), oil-film bearings
- **Backup roll thrust position:**
TDIK, 2TSR required with cylindrical bearing and oil-film bearings
- **Work roll radial position:**
TQOW, 2TDIW
- **Work roll axial position:**
TDIK, 2TSR (in case of axial shift)

HOT MILL

Hot rolling is primarily intended to reduce the thickness of the material that leaves the roughing stand or the continuous caster. In modern hot strip mills, the dimensional control of the finished strip is critical and affected by important strip characteristics such as thickness, profile and flatness. The product from the finishing stands is coiled and, subsequently used as feed stock for cold rolling or used directly by fabricators.

Mill speed: generally less than 1000 m/min. (3300 ft./min.)

Roll neck bearings:

- **Backup roll radial position:**
TQOW, 2TDIW, multi-row cylindrical (RX) or oil-film bearings
- **Backup roll thrust position:**
TDIK, 2TSR, TTDWK required with cylindrical and oil-film bearings
- **Work roll radial position:**
TQOW, 2TDIW
- **Work roll axial position:**
TDIK, 2TSR (in case of axial shift)

COLD MILL

The cold rolling process, unlike hot rolling, deforms metal at temperatures below its recrystallization temperature. This results in cold working of the material and an increase in its strength and hardness. While cold rolling increases the hardness and strength of a metal, it also results in a large decrease in ductility. Therefore, most ferrous products exiting the cold mill must go through both annealing (heating) and temper rolling operations.

Mill speed: 1000 m/min. (3300 ft./min.) to above 2000 m/min. (6500 ft./min.)

Roll neck bearings:

- **Backup roll radial position:**
Multi-row cylindrical (RX), TQIT or oil-film bearings
- **Backup roll thrust position:**
TDIK, 2TSR required with cylindrical and oil-film bearings
- **Work roll radial position:**
TQOW or 2TDIW
- **Intermediate roll radial position:**
TQOW or 2TDIW
- **Work roll and intermediate axial positions:**
TDIK, 2TSR (in case of axial shift systems)

TEMPER MILL

The temper mill, also referred to as skin-pass mill, is a cold rolling mill used for tempering the strip by making a small thickness reduction (about two percent). The design of the rolling mill can be 2-Hi, 4-Hi or 6-Hi. The physical properties that are enhanced by the temper pass due to slight elongation of the product include:

Dimensional trueness and repeatability,

Suppression of yield point elongation,

Improved surface finish, and

Improved shape and flatness.

Mill speed: generally <1200 m/min. (3950 ft./min.)

Roll neck bearings:

- **Backup roll radial position:**
Multi-row cylindrical (RX), TQIT
- **Backup roll thrust position:**
TDIK, 2TSR required with cylindrical
- **Work roll radial position:**
TQOW, 2TDIW
- **Intermediate roll radial position:**
TQOW, 2TDIW

LONG PRODUCT ROLLING

The long products description applies to a wide variety of semi-finished and finished products. These include round, rectangular and hexagonal bar, seamless and welded tubes, structural sections such as channels and beams, rails, rod and wire.

Despite the wide range of products, the overall process is similar to that for flat products. The starting point is a cast billet, bloom or cast bloom that is processed through roughing and finishing mills using both hot and cold rolling. After rolling the product moves on to finishing operations such as straightening, reeling and sizing.

The wide range of long products is reflected in the many styles of rolling mills used by their manufacturer. They include, but are not limited to:

- 2-Hi and 3-Hi reversing bar mills.
- Multi-stand 2-Hi bar mills with overhung (cantilevered) rolls.
- Piercing and sizing mills with inclined rolls for seamless tube.
- Forming and welding lines for welded tube.
- Universal mills combining horizontal and vertical rolls for sections and rails.
- High-speed, multi-stand mills for rod and wire products.

Like flat product mills, these are extremely demanding applications for the rolling mill bearings. In addition, the rolling of asymmetrical shapes can introduce axial loads that are higher, relative to the radial loads, than seen in flat product mills. For this reason the roll neck bearing configuration (fig. 54) usually includes a separate thrust bearing.

Roll neck bearing selection criteria are similar to those for flat products but the variety of mill types and designs means that there will be variations, due to dimensional constraints.

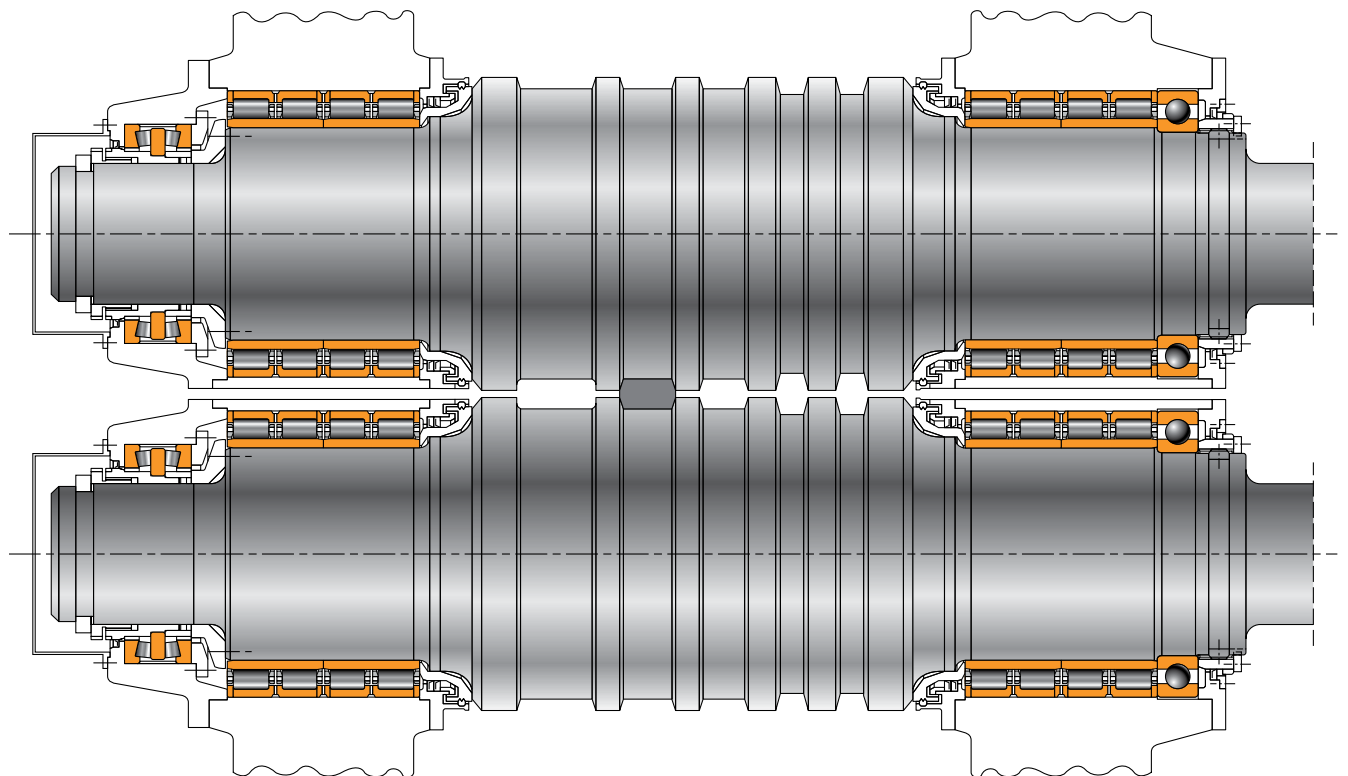

Fig. 54. Typical roll and bearing arrangement for a bar mill.

BEARING SOLUTIONS: RADIAL POSITIONS

WORK AND INTERMEDIATE ROLLS: FLAT PRODUCT MILLS

Work roll bearings have a smaller section height and a much narrower width than a backup roll bearing (see page 46 for backup roll solutions), because loads are significantly lower at this position.

The work roll bearing is sized as a function of the work roll's neck and body diameters. The neck diameter is influenced by the coupling diameter necessary to transmit the required torque.

The shape of the strip's cross-sectional profile can be adjusted dynamically by shape (or flatness) control systems. These systems adjust the shape of the roll gap across the mill width, such that flat strip can be produced. The need for closer tolerances, improved strip flatness and increased productivity all put increased demands on the work roll bearings. Several of the techniques used for controlling strip flatness are discussed below.

FLATNESS CONTROL TECHNIQUES

Roll bending: Roll bending was first introduced as a means of improving the strip profile and flatness. Later, roll bending (fig. 55) was introduced to hot strip mills to improve upstream product quality (profile).

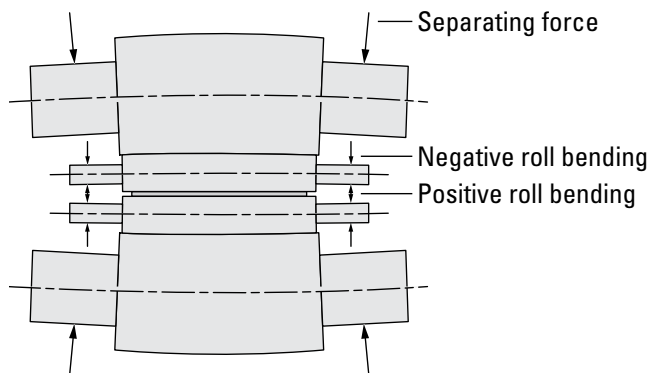

Fig. 55. Roll bending.

The roll bending technique induces significantly higher radial loads on the work roll bearings than are seen in conventional mill stands. Bending loads (per chock) in excess of 80 metric tons on cold mills and above 200 metric tons on hot mills are typical. These higher loads combined with smaller chock sections require careful consideration. A Finite Element Analysis (FEA) of the chock/bearing system may be needed in order to validate the catalog L_{10} life calculation due to the chock bore deformation resulting from the high applied loads. An example of how the loading may be distributed among the rollers around the circumference of the bearing is illustrated below (see fig. 56). This load distribution often is referred to as rabbit ears – where the roller loading at the center of the load zone is lower than at the adjacent quadrants where the chock section is larger.

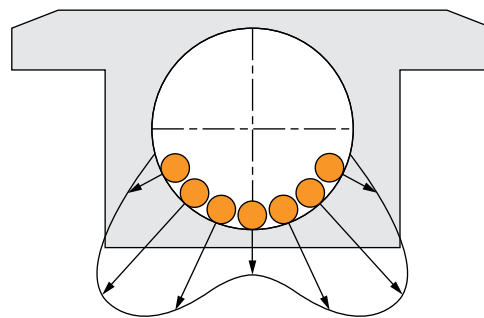

Fig. 56. Rabbit ears shaped roller load distribution.

These analysis have shown that both vertical and horizontal chock sections (a and b) in fig. 57 are critical to chock deflection and bearing performance.

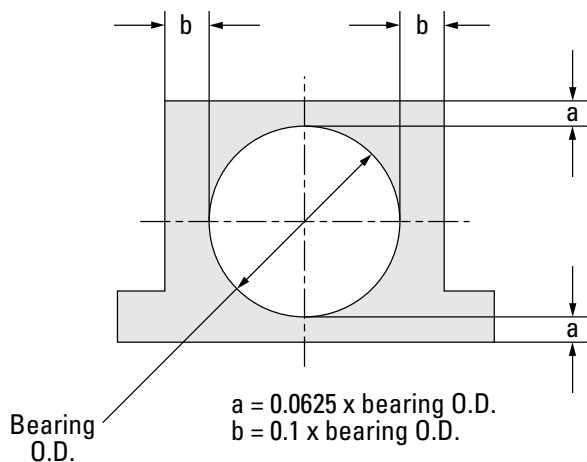

Fig. 57. Work roll chock sections (symmetrical chock).

Axial roll shifting and roll crossing: Roll shifting can be used in addition to roll bending to further increase control of the roll gap profile. Axial roll shifting (fig. 58) combined with a special roll body profile is used to change the shape of the effective roll gap. Roll shifting is generally applied without loads to the work rolls of a 4-Hi mill or to the intermediate rolls of 6-Hi mills.

In roll-crossing systems (fig. 59), additional mechanical actuators displace the roll ends in opposite directions in the horizontal plane resulting in crossing of the rolls. This crossing also results in a change of the effective roll-gap profile.

Both of these flatness control systems generate higher roll thrust loads than are seen in a conventional mill stand and typically require a separate thrust bearing. With this configuration, radial loads are absorbed strictly by the four-row bearing, while the thrust loads are absorbed by the thrust bearing. There are exceptions where relatively steep angled four-row tapered roller bearing (TQOW type) assemblies accommodate both the radial and axial loads. However, these exceptions require detailed analysis to ensure appropriate bearing selection.

Thrust bearing selection is discussed later in this chapter.

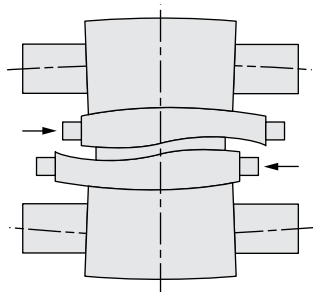

Fig. 58. Axial roll shifting.

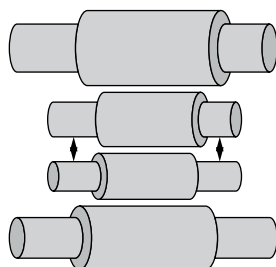

Fig. 59. Cross rolling.

BEARING SELECTION: DIMENSIONAL CRITERIA

Work roll: The size of the work roll bearing assembly is constrained by the roll neck diameter, the chock outside dimensions, and the position of the balancing and bending cylinders. These constraints will limit the minimum allowable bearing bore, the maximum allowable outside diameter (O.D.) and the proper position of the bearing rows.

Bearing bore per roll neck size requirement: The neck diameter can vary greatly according to the material used for the rolls. The neck-to-barrel ratio range is approximately 45 to 50 percent for cold mills where steel rolls are used and approximately 55 to 60 percent for hot mills where various grades of cast iron rolls are used.

Bearing O.D. per chock section requirement: Work roll bearing selection requires careful analysis of the space available between the mill pass line and the backup roll chock. The minimum radius of the work roll body must exceed the height of the work roll chock from the chock's center-line to the pass line to ensure roll contact without chock interference.

The work roll chocks are either symmetrical (fig. 60) or non-symmetrical (fig. 61) versus the chock's center-line. The non-symmetrical chock (with a smaller section height toward the pass line) allows for a smaller minimum work roll O.D. for the same bearing O.D.

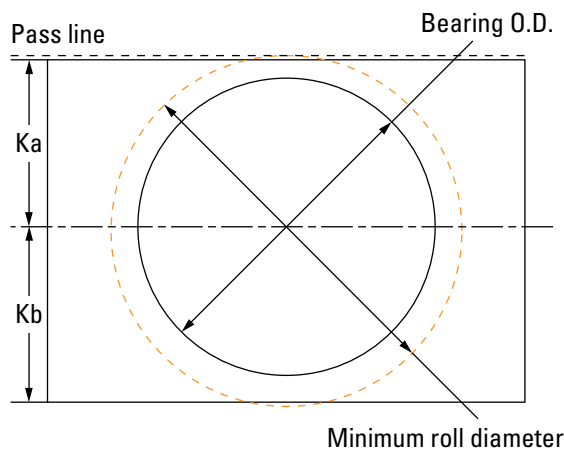

$$\begin{aligned} \text{Minimum roll diameter} &= 1.125 \times \text{bearing O.D.} + 2 \text{ mm (0.078 in.)} \\ K_a \text{ (min.)} &= K_b \text{ (min.)} = 0.562 \times \text{bearing O.D.} \end{aligned}$$

Fig. 60. Symmetrical work roll chock.

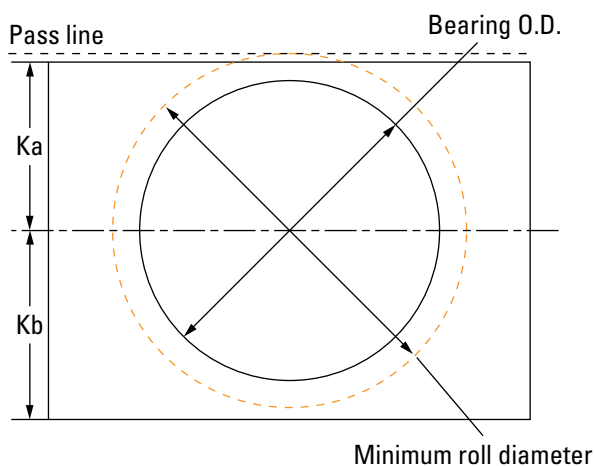

$$\begin{aligned} \text{Minimum roll diameter} &= 1.100 \times \text{bearing O.D.} + 2 \text{ mm (0.078 in.)} \\ K_a \text{ (min.)} &= 0.550 \times \text{bearing O.D.} \\ K_b \text{ (min.)} &= 0.575 \times \text{bearing O.D.} \end{aligned}$$

Fig. 61. Non-symmetrical work roll chock.

UNSEALED ROLL NECK BEARINGS

The four-row tapered roller bearing, TQOW type or 2TDIW type, is the preferred solution for flat product work and intermediate rolls as it offers many advantages:

- Unitized construction, once assembled in the chock, facilitates installation and removal from the roll neck.
- Rolling elements are protected against handling damage during chock removal and installation on the roll neck.
- Ability to handle both axial and radial loads simultaneously. A separate thrust bearing is typically not required.
- The bearing's internal clearance can be reset, if necessary, after a period of use by regrinding spacers.
- 2TDIW with reduced axial tolerances enables more compact and simpler mounting arrangements without adjustable retaining system (see fig. 62).

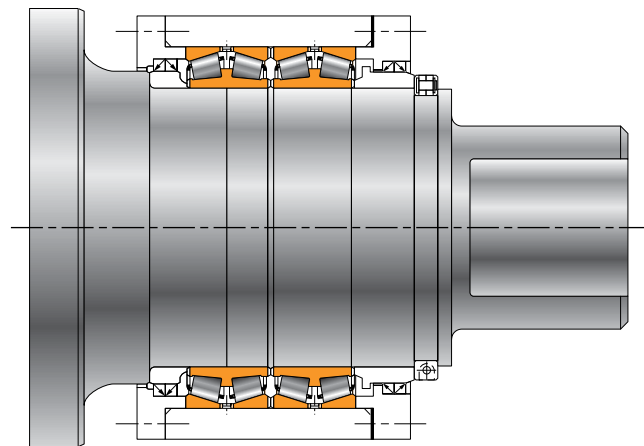

Fig. 62. 2TDIW simplified mounting arrangement.

Bearing types: Many existing mills have been designed with steeper angle work roll bearings compared to the backup roll bearings to cope with axial loads caused by poor mill alignment. This situation may be encountered in older mills with worn chocks, housings and liners. Although steeper angle designs increase the bearing's thrust capacity, the radial capacity is reduced.

Type TQOW: Widely used in the work roll position. This bearing consists of two double cones, two single cups and one double cup. The two cup spacers and hardened cone spacer are needed to establish internal clearance at the factory.

Type 2TDIW with cone and cup spacers: Similar to the above TQOW arrangement, but with the double cup replaced by two single cups.

Type 2TDIW without cone spacer: Simplest and most compact design. Tighter width tolerances allow simplified mounting arrangement (fig. 62).

Type 3TDIW: The six-row tapered roller bearing also can be considered in order to achieve an even higher radial capacity when the bearing's cross section is particularly constrained. Six-row bearings are in use on the work rolls of some hot and cold aluminum mills and also are designed into 4-Hi steckel mill work rolls.

Type extra-wide 2TDIW: Extra-wide central cone and cup spacers (fig. 63) are provided to separate the inboard two rows from the outboard rows where roll shifting causes the radial load from the bending cylinders to shift with respect to the bearing center-line. The wide spread allows for improved distribution of load among the four rows.

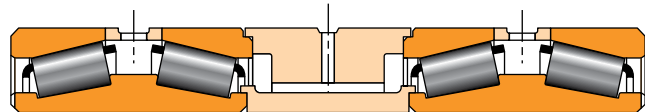

Fig. 63. 2TDIW extra wide.

Extended ribs for added sealing (TQOWE or 2TDIWE): The space necessary for an integral seal often requires a slight decrease in bearing rating due to the seal's space requirement. An alternative to avoid any capacity decrease is to install, at the original equipment manufacturer's stage, a four-row bearing with extended small ribs on the double cones (fig. 64). Here, the chock seal rides on the plunge-ground surface of these extended ribs and provides a more efficient chock-bearing sealing system. In addition to improved sealing, this configuration also protects the seal from potential damage during chock assembly and disassembly.

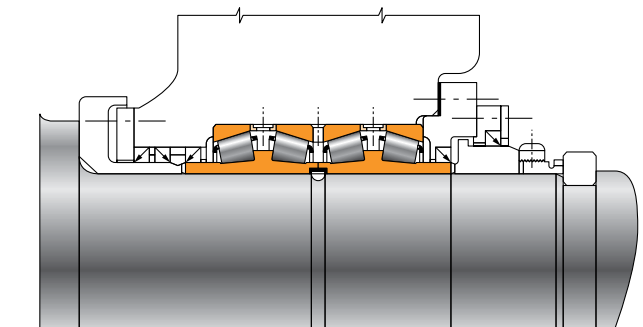

Fig. 64. TQOWE extended ribs.

SEALED ROLL NECK BEARINGS

Sealed roll neck bearings are popular due to the need to reduce costs associated with grease consumption and disposal, simplifying bearing maintenance and maximize bearing life. The sealed roll neck bearing does not require regreasing at each roll change, allowing for cleaner mills and less contamination of roll coolants.

In addition to reduced contamination and improved lubricant retention, enhanced greases have been developed. These greases can further improve bearing performance. The sealed roll neck bearing is available non-greased or pregreased with one of a range of enhanced mill greases to suit your particular application.

The space requirements for the seal are kept to a minimum in order to maximize the bearing's capacity. Timken sealed roll neck bearings typically have the same capacity as the equivalent sized open bearing (see product tables for further details).

The benefits of using sealed roll neck bearings include:

- Reduced risk of contamination ingress and related damage, which increases bearing reliability and life.
- Minimized maintenance costs through reductions in grease consumption and disposal charges.
- Reduced risk of strip staining and rolling solution contamination.
- Extended maintenance intervals reducing the number of inspections required per year.
- Reduced grease contamination of cooling water and/or rolling solution resulting in cleaner environment.

Integrated seal design

The integrated configuration features two main seals that are mounted within counterbores in the extended outer cups. The integrated seal design (fig. 65) is typically supplied according to the configuration below.

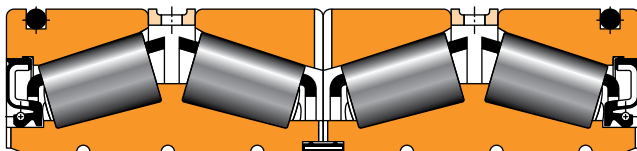

Fig. 65. Integrated seal design.

The main seal lip rides on the extended inner-ace small rib and functions to exclude contaminants and retain grease (fig. 66).

The bore seal (fig. 67) is a static seal that prevents ingress of rolling solution from the cone bore, while allowing venting of excess internal pressure.

When used with an air-oil system, the bore seal can be omitted to help with venting and bore/roll neck lubrication. O-rings are incorporated in the O.D. of the outboard cups to keep contamination from entering at the bearing's outside diameter.



Fig. 66. Main seal.

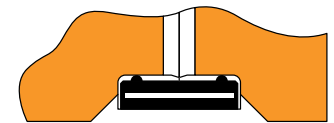

Fig. 67. Bore seal.

The sealed roll neck bearing can be supplied with allowance for in-chock regreasing. In this configuration, grease inlets are provided in the cup spacers and vent slots between the two central cups as shown in fig. 67. Alternatively, sealed roll neck bearings can be supplied with solid cup spacers and without vent slots for those applications where in-chock regreasing is not a requirement.

Other features include:

- Face slots on all cone faces (inboard and outboard) for enhanced lubrication or to reduce face wear caused by cone creep.
- Spiral bore grooves that act as a neck lubrication reservoir to reduce roll neck wear.
- The single cups provide optimal load sharing across the four rows, however a center double cup also can be provided.
- Tight width tolerances simplify chock and roll neck design, assembly and maintenance.

Seal carrier design

The seal carrier design includes heavy-duty main seals in independent seal carriers. O-rings are incorporated in the seal carrier O.D. to prevent contamination entering at the carrier's outside diameter. The bore seal is similar to the design used in the integrated seal design.

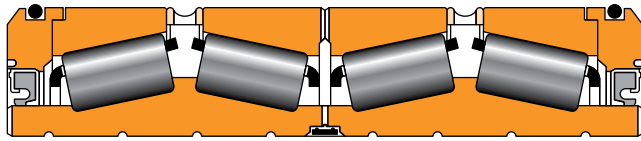

Fig. 68. Seal carrier design.

The seal carrier design configuration above (fig. 68) features the same basic internal design features as the standard TQOW bearing, but includes separable extended inner rings and main seal carrier rings. This bearing is wider than the equivalent open bearing and the roll neck/chock must be designed accordingly.

OPTIONAL ROLL NECK BEARING FEATURES

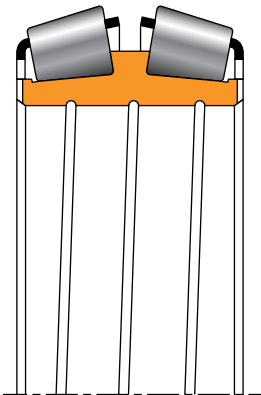

Fig. 69. Spiral groove in bearing bore.

The TQOW assembly is the most popular four-row assembly. However, there are variants to this basic assembly that may be specified to suit a specific application.

1. Spiral bore grooves in double cone bore (TQOGW): Spiral grooves in the cone bores (fig. 69) help to retain and distribute lubricant between the neck and inner ring. However, Timken suggests that the contact pressure between the roll neck and cone bore be less than 15 MPa (2175 psi) to minimize the risk of

premature neck scuffing. There are exceptions, however, where mills running at slow speed have been able to increase this neck contact stress limit up to 20 MPa (2900 psi).

2. Reduced assembly width tolerance (2TDIW): Assembly on the roll consists of a thrust ring, adjusting assembly (normally thread ring and nut) and a split ring. Typically, at assembly, the adjusting nut is tightened so that all components are axially seated against the fillet ring or roll neck shoulder. It is essential to then back off the adjusting nut to leave an axial clearance of between 0.25 to 1 mm (0.010 to 0.040 in.) or even more for large bearings. This axial clearance allows the cone to creep relative to the roll neck without additional friction from axial clamping forces.

In the case of the 2TDIW concept, the tolerance on overall inner ring width is controlled so that it makes it possible to eliminate the adjustment system. The only components needed to locate the bearing on the neck are the thrust ring (used also for seal seat) and the split-hinged ring. The 2TDIW assembly affords the opportunity of shortening the roll neck considerably by eliminating the need for threaded adjustment rings (fig. 70).

This retaining system further ensures the cones are kept free axially with the suggested clearance.

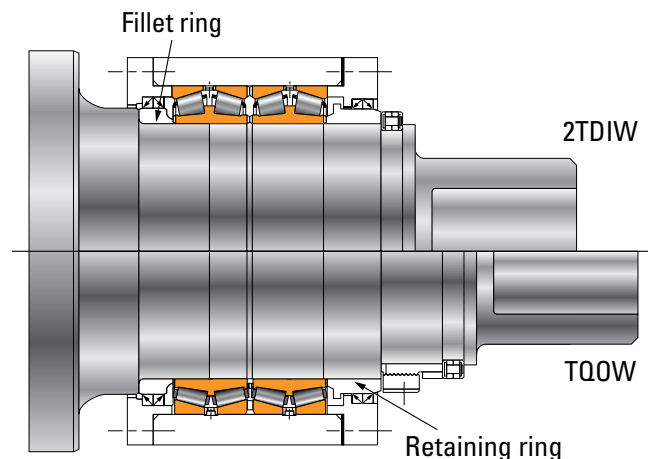

Fig. 70. Shorter roll neck possible with 2TDIW versus TQOW.

APPLICATION CONSIDERATIONS: FOUR-ROW TAPERED BEARINGS

1. Mounting practice: Quick mounting and removal of the chock-bearing system is mandatory due to the requirement for frequent work roll changes. Therefore, a loose fit on the roll neck is standard practice at the work and intermediate roll positions regardless of the rolling speed.

Given that the roll neck diameter is smaller than the cone bore, there will be a natural tendency for the double cones to creep circumferentially on the neck. The roll neck and cone bore essentially have the same linear velocity where they are in contact with each other. The cone's RPM is slightly less than the RPM of the roll neck as illustrated in fig. 71, due to the small diameter difference between roll neck and cone bore. Therefore, it is essential that:

- Axial clearance is provided between the cones and abutting faces to allow the two cones to creep freely and avoid face wear.
- The minimum roll neck diameter guidelines are respected to avoid excessive neck wear due to this creep.

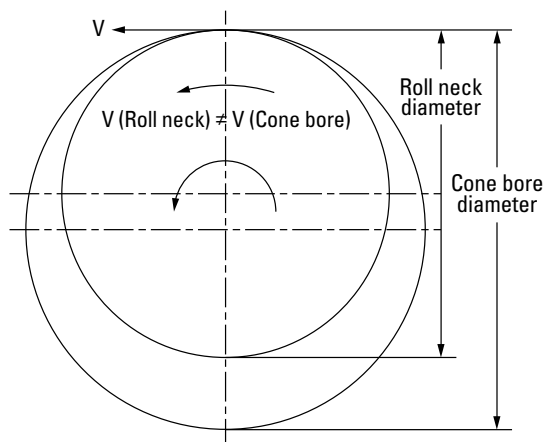

Cone RPM = (roll neck diameter/cone bore diameter) roll RPM
NOTE: Diameter differences are exaggerated here for illustrative purposes.

Fig. 71. Cone creep.

2. Neck lubrication: The roll neck must be coated with a lubricant to minimize roll neck scuffing due to the creep phenomenon. This lubricant is normally the same that is used in the bearing assembly. In applications where neck wear may be excessive, the use of specialized lubricants can be investigated.

When air-oil systems are used, the oil can be supplied to the neck through slots in the cone faces and radial holes in the ribs of the inner rings. This supplements the initial roll neck/cone bore lubrication supplied at roll mounting.

3. Unclamped inner rings: The cone contact faces should be hardened to approximately 55 to 60 HRC in order to help prevent excessive wear.

4. Clamped outer rings: The end cover must clamp the cups tightly in the chock with specified bolt torque to ensure that the established clearance in the bearing assembly is maintained.

5. Roll neck hardness: The preferred minimum hardness level is 45 shore C (33 HRC) to reduce wear at the cone bore to roll neck interface.

6. Roll neck undercuts: To accommodate potential wear, an undercut is required on the roll neck. The undercut depth is typically 0.8 mm (0.032 in.) on diameter and extending 1.6 mm (0.063 in.) beyond the tangency points of the front face radius beneath the cone spacer (fig. 72) and 3.2 mm (0.125 in.) beyond the tangency point at the outer cone face.

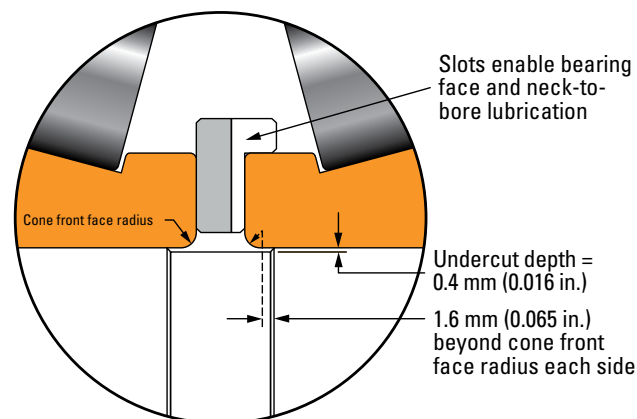

Fig. 72. Roll neck undercut at center of bearing assembly (applies to loose-fit assemblies only).

7. Chock bore undercuts: Undercut 0.8 mm (0.032 in.) on diameter and 1.6 mm (0.063 in.) beyond the tangency points of the cup backface radii beneath each cup spacer and 3.2 mm (0.125 in.) at the end of the outer single cup. These undercuts are only required in the backup roll chocks.

8. Retaining ring: The retaining ring is keyed to the roll neck and sometimes includes an O.D. shoulder so that it will remain with the chock and bearing assembly when removed from the roll neck (fig. 72). The suggested fit of the retaining ring on the roll neck is similar to the fit used for the TQOW cone fitting practice.

9. Fillet ring design: The fillet ring (fig. 70) should have a press-fit on the roll neck with a minimum tight fit of $0.00025 \times$ bearing bore. The length of the cylindrical seat piloting the fillet ring must provide sufficient press fit to prevent movement on the roll neck. The seal seat should be plunge ground to a 0.25 to 0.50 μm (10 to 20 $\mu\text{in.}$) surface roughness. The seal seat should be 35 HRC minimum to reduce wear caused by seal lip-pressure.

10. Cone backing (provided by fillet ring and retaining ring):

- The cone backing diameter should be the maximum possible. All Timken assemblies have minimum suggested backing diameters that should be considered in the design of the mating components (fillet ring and retaining ring).
- Most roll neck bearings include double cones that include slots in the cone front faces (DW suffix) and therefore, no slotting is required of the mating surfaces.
- When using double cones with no face slots (D suffix), the face of the fillet ring and retaining ring must include lubrication slots. The edge of the slot and face should be well blended to minimize wear with respect to the mating cone front face.
- Face hardness of both the fillet ring and retaining ring should have a minimum hardness of 50 HRC and a preferred hardness of 55 to 60 HRC.

11. End covers: In multi-row tapered roller bearings, the end covers and screws need to resist the induced axial load and must be sized accordingly.

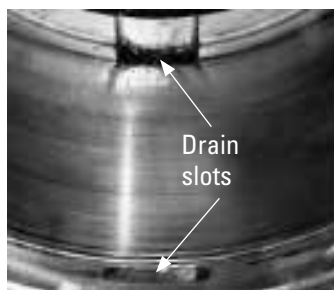

Fig. 73. Sealed work roll bearing – drain slots.

We suggest to correctly size drain slots or holes, depending on the application. They should be inspected and cleared of trapped grease when necessary at each roll change.

12. Chock drainage (sealed roll neck bearings):

Chock drainage slots (fig. 73) or holes (fig. 74) are a requirement between the chock seals and the bearing, on both sides, when sealed roll neck bearings are used. This minimizes pooling of rolling solution or water against the bearing's main seals.

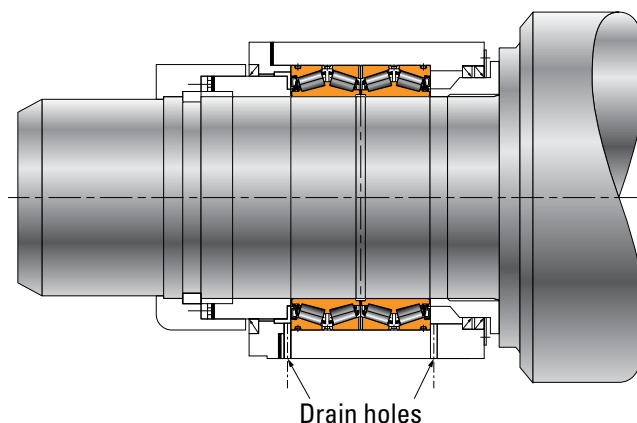

Fig. 74. Machine two slots through the bottom dead center of chocks and cover plates to prevent water damming.

WORK ROLLS: LONG PRODUCT MILLS

Long product mills are typically a 2-Hi construction, as compared to the 4-Hi or 6-Hi constructions found in flat product mills. In some cases a 3-Hi reversing mill also may be used in the roughing stands of long product mills.

In the 2-Hi construction the rolling loads are transferred directly to the mill frame through the work roll bearings. The dimensional constraints are only dictated by the work roll chocks and the roll neck because the bearings are not typically supported by a backup roll position. The radial bearings are either four-row cylindrical bearings with a separate thrust bearing or two- or four-row tapered roller bearings.

TAPERED ROLLER BEARING

Two-row assemblies for bar and rod mills

Two-row tapered roller assemblies often are used when space limitations (width constraints) would make it impossible to integrate the wider four-row assembly. These two-row matched assemblies are suitable for low to medium radial and thrust loads. The selection of either the loose-fit TDIW assembly or tight-fit TDIT assembly is dependent on the anticipated speed of the mill.

TDIW or TDIGW assembly for lower speed stands: The TDIW assembly (fig. 75) is mounted on the neck with a loose fit and is suitable for roll speeds approaching 760 m/min. (2500 ft./min.). The loose fit permits quicker roll changes. These bearing assemblies are typically found in roughing stands and follow similar maintenance guidelines to the TQOW assembly, such as greasing the neck before installing the bearing and chock assembly. Spiral bore also are available in the double cone for additional lubrication access to the roll neck.

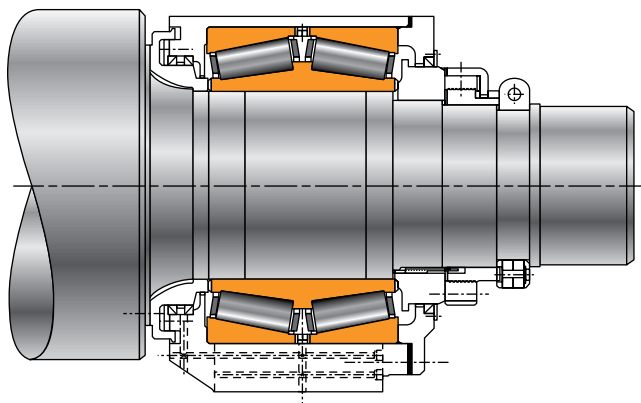

Fig. 75. TDIW mounting.

TDIT assembly for high-speed stands: The TDIT assembly (fig. 76) is mounted tight using a 1:12 taper on the roll neck and the bearing bore for accurate control of the interference fit. The tight fit allows higher roll speed mills of up to 1800 m/min. (6000 ft./min.). The bearing setting is preset prior to installation while the cone fit is established by the fillet ring adjacent to the roll body. The roll neck is drilled to allow removal of the cone with hydraulic fluid pressure. As the cups are axially clamped within the chock at both ends of the roll, the chock must float in the stand to accommodate the roll's thermal expansion.

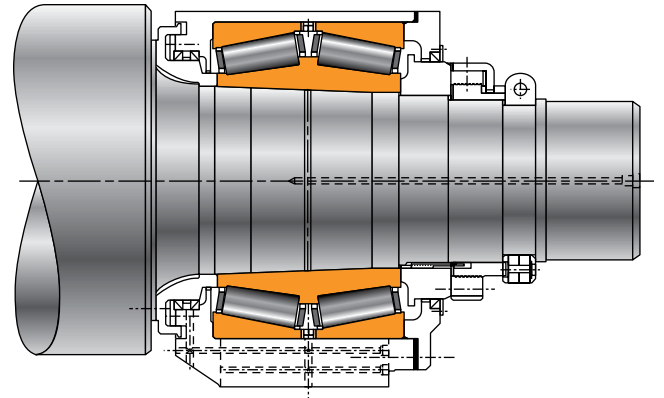

Fig. 76. TDIT mounting.

TNAT assembly for high-speed pre-stressed mills: The TNAT assembly (fig. 77) is mounted tight using a 1:12 taper on the roll neck and bearing bore. The clearance is preset prior to mounting in order to establish the needed running clearance during mill operation. This arrangement is used in the case of pre-stressed chocks where both chocks are fixed. As noted in fig. 77, the fixed bearing at the operator side of the mill dictates that the double cup be clamped axially, whereas the opposite chock includes a gap between the chock's shoulder and cover spigot to permit floating of the cup within the chock bore.

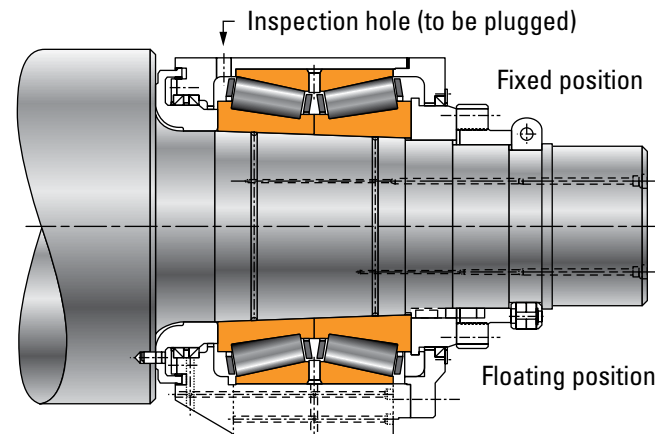

Fig. 77. TNAT mounting.

FOUR-ROW CYLINDRICAL ROLLER BEARING

Timken offers a wide range of four-row cylindrical roller bearing sizes used in long products starting at 145 mm (5.709 in.) bore. The most common designs are finger-type cages of the RY or RYL type. The RX-type configuration is also used for the larger sizes.

The fixed chock (normally at the operator side) requires an additional thrust bearing outboard of the cylindrical bearing assembly. The thrust bearing type varies by mill type and builder but is typically a two-row thrust ball bearing to absorb external thrust loads inherent in the rolling process. For larger mills or mills with higher axial loads, spherical thrust or tapered thrust type TTDWK are used (fig. 78). The floating chock requires an additional thrust bearing (generally a deep-groove ball bearing) except when the floating chock is connected to the fixed chock.

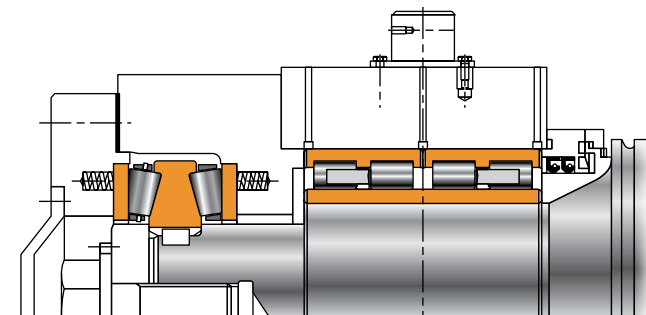

Fig. 78. Bar mill with TTDWK thrust bearing.

The housing fitting practice for the radial bearing usually results in a loose fit to facilitate easy removal at regular maintenance intervals. The preferred roll neck fitting practice is to tight fit the inner ring on the roll neck. There are occasions where loose roll neck fits are applied, such as on some roughing-mill equipment. In the cases where the roll neck fit is loose, inner ring spiral bore grooves are incorporated. In order to facilitate the dismounting, face slots can be added on the inner rings (W30B modification code).

Inner rings can be ordered separately from the outer assembly in order to equip additional spare rolls.

Type RY

The RY bearing style incorporates two outer rings with triple flanges (solid ribs). The inner ring is usually of single-piece construction. The outer assemblies consist of the outer ring, rollers and cages that create a unitized construction. A loading slot is used for roller insertion. Lubrication is generally accomplished via slots in the faces of the outer ring or lubrication groove and holes in the outer ring ribs (modification code W33). The cage is a single piece, fully machined brass or steel finger-type construction. The roller pockets are staggered between the races.

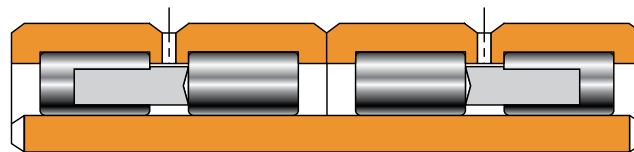

Fig. 79. RY construction with single inner ring (ARVS).

Cylindrical part numbering system (RY type): The first three or four digits representing the bore size (in. mm); RYS designates the outer assembly with the first three or four digits representing the diameter under roller (DUR); ARVS is used to designate the one-piece inner ring design (fig. 79), and ARYS denotes the two-piece inner-ring configuration.

It also is important to note that the clearance designation (typically C3 or C4) will only be shown for the inner-ring set (ARYS or ARVS) and the complete assembly (RY).

Type RYL

The most recent RYL designs are available in sizes up to 340 mm (13.39 in.) bore and specifically designed for long product mills. Standard steel cage and enhanced design features are included to maximize bearing life, reduce roller drop and optimize bearing handling.

The RYL bearing style is similar to the RY except the standard lubrication is accomplished via slots in the faces of the outer ring (fig. 80). Lubrication holes and groove in the outer- race ribs can be specified by modification code W33. The cage is a single piece, fully machined steel finger-type construction.

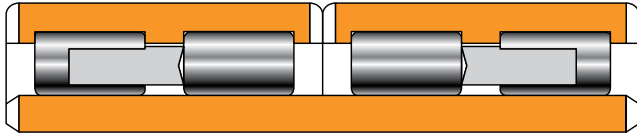

Fig. 80. RYL construction with single inner ring (ARVSL).

The part number designation is similar to the RY type with the addition of an L suffix to the assembly. RYSL designates the outer assembly and ARVSL or ARYSL is used to designate the inner ring set.

The standard RYL features are:

- Finger-type machined steel cages.
- Single- or two-piece inner ring.
- Lubrication slots on the outer-ring faces.
- Profiled inner ring chamfers.
- Reduced roller drop.

For mill operators with frequent roll changes, the RYL type is preferred. The inner ring chamfer and reduced roller drop decrease the common risk of bearing damage caused by collision damage between the inner ring and the rollers during the roll change operations.

Complete outer assemblies are interchangeable with inner ring assemblies and can be purchased separately.

Application considerations: four-row cylindrical roller bearings

1. Fitting practice: Cylindrical bearings used in long products rolling mills are generally mounted with a tight fit of the inner rings on the roll neck.

The inner rings must be heated prior to installing on the roll neck (see page 162 for details).

2. Radial internal clearance (RIC): Four-row cylindrical roller bearings are available with radial clearances according to DIN 620-4. Most long product applications use C4 or sometimes C3 radial internal clearance values.

The RIC is established by two parameters: the diameter under rollers (DUR) and the inner ring O.D. (IROD). The DUR is fixed for the bearing assembly, while the IROD is determined by the RIC value, depending upon the amount of tight fit of the latter. Both the DUR and IROD will have an inherent tolerance on their respective diameters. This results in a range of internal clearance (RIC).

$$\begin{aligned} \text{Minimum DUR} - \text{Maximum IROD} &= \text{Minimum RIC} \\ \text{Maximum DUR} - \text{Minimum IROD} &= \text{Maximum RIC} \end{aligned}$$

Four-row cylindrical roller bearings also are available with a tapered bore.

3. Lubrication configuration: Timken bearings can be used with grease, air-oil, oil-mist or circulating-oil systems. The bearings must be correctly lubricated for maximum performance through either lubrication grooves and holes in the outer-ring O.D. (W33 modification code) or through integrated face slots on the outer-ring faces.

BACKUP ROLLS

The first step in bearing selection is determining the amount of space available for the bearing, which is dictated by both the roll and chock design requirements.

Bearing selection criteria: Initial bearing selection is based on envelope requirements, including bore and O.D. constraints. Roll neck bearings are first selected using the following parameters:

- Ratio of roll neck diameter to maximum roll body size.
- Roll body size (minimum diameter).
- Allowable roll neck stresses.
- Distance between mill screwdowns.

These considerations dictate the minimum remaining space for the chock and bearing. It is important to balance the bearing section (cup O.D. – cone bore) against the minimum chock section requirements. The mill builder is seeking to maximize chock section and neck diameter, which directly impacts the bearing's size and capacity. According to the mill builder's expertise, the space for the bearing is specified.

After a review of the bearing's dimensional constraints, an evaluation must be made of the bearing capacity as a function of the rolling schedule for each mill stand to determine design requirements. This is an interactive design process that establishes the best balance between all mill components, including the roll, chock and bearing that takes into consideration:

- Roll neck to roll body ratio.
- Minimum allowable chock sections.
- Roll neck fillet radius.

Roll neck to roll body ratio: The normal backup roll neck-to-barrel ratio is approximately 60 percent (between 58 percent and 62 percent). However, there are some exceptions, such as heavily loaded plate mills, where the required roll neck-to-barrel ratio may be as high as 68 percent. In these cases, a lighter section bearing may be required since the bearing O.D. is limited by the chock section requirements. In these cases, an enhanced steel material (MAP) can be used to increase the bearing's capability.

Backup chock section guidelines: The chock section guidelines can be applied to all backup roll bearings that will be discussed in this section including four-row cylindrical assemblies, loose-fitted tapered roll neck (TQOW) and tight-fitted tapered roll neck bearings (TQITS).

Timken's heavy-duty backup bearings usually allow a neck-to-barrel ratio between 58 and 62 percent, and a roll turndown from new roll diameter of about 10 percent provided the chock section dimension C is satisfied as shown below (fig. 81).

For highly loaded mills, Timken engineers can use FEA to better evaluate the stresses and deflections at minimum chock sections (A, B and C) in the vertical and horizontal planes.

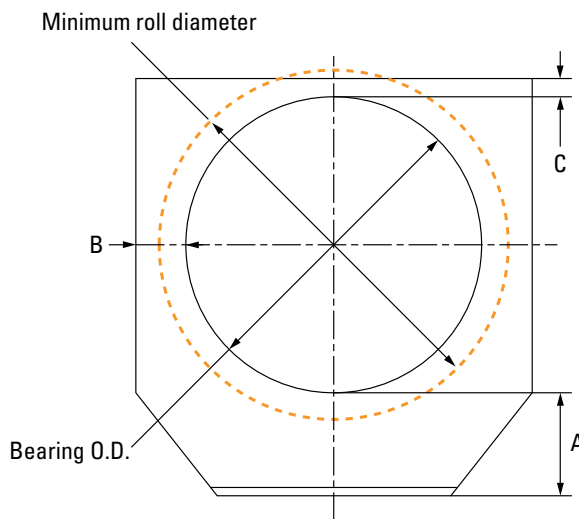

- A minimum = 0.2 x bearing O.D.
- B minimum = 0.1 x bearing O.D.
- C minimum = 0.038 x bearing O.D.
- Minimum roll diameter = 1.075 x bearing O.D. + 2 mm (0.078 in.)

Fig. 81. Critical backup chock sections.

A good approximation for calculating the maximum allowable bearing O.D. is to use the following equation:

$$\text{Percent turndown} = \frac{\text{Max. roll dia.} - \text{Min. roll dia.}}{\text{Max. roll dia.}} \times 100$$

Roll neck compound fillet radius: The use of a roll neck fillet with a conventional single radius is not desired due to strength and space limitations. Compound or two-radii fillets are a practical solution because they offer a design similar to the optimum elliptical fillet contour, and are easier to machine.

Fig. 82 shows the development of the compound radii fillet from two predetermined fillet length and height dimensions: r_a and r_b , respectively. Knowing the length and height (r_a and r_b) of the fillet radii, you can then determine r_c and r_d using the following formulae:

$$r_c = r_a + \frac{(r_a - r_b)^2}{2(r_b - r_d)} \quad r_d = \frac{4r_b - r_a}{3}$$

where:

- r_a = Fillet length (r_a is less than 2.5 r_b for practical purposes)
- r_b = Fillet height
- r_c = Major radius of compound fillet
- r_d = Minor radius of compound fillet

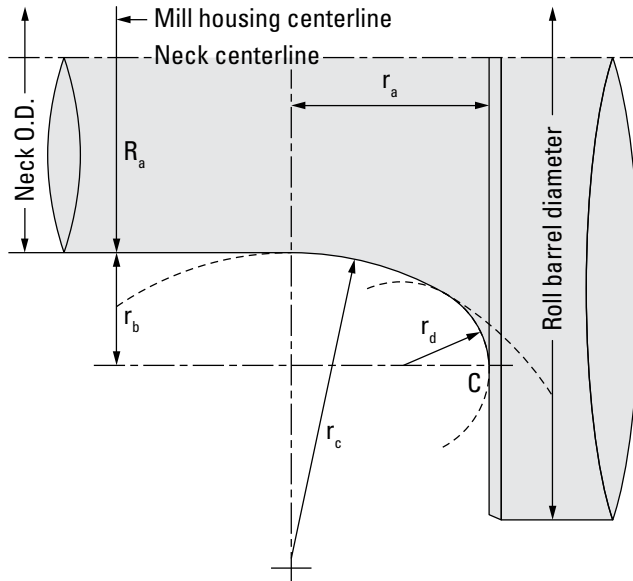

Fig. 82. Compound fillet radius.

Calculating maximum roll neck bending stress: Fig. 83 shows the working diameter, D_E , and the working length, L , of the neck, which are used in calculating maximum bending stress. An equal stress curve is plotted to pass from $R_a/3$ to be tangent to the major radius (r_c) of the fillet. The equivalent neck diameter (D_E) and effective working length of the neck (L) can then be conveniently determined by the graphical solution (fig. 83).

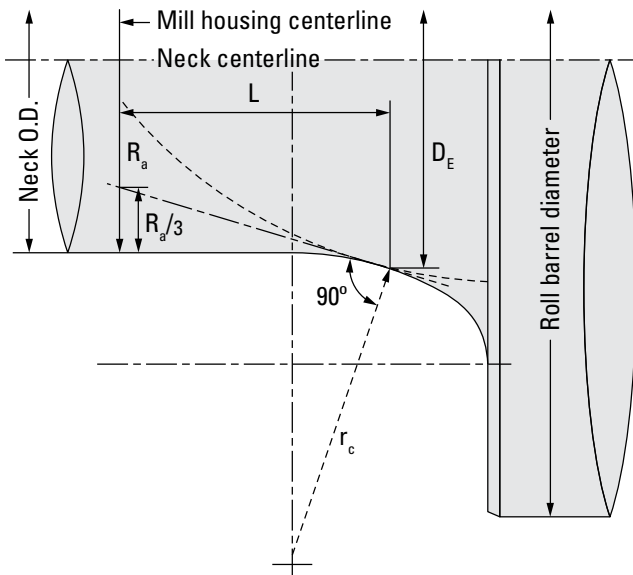

Fig. 83. Graphic solution.

Note that D_E and L can be approximated by the following equations:

$$D_E = \text{Cone bore (d) or neck O.D.}$$

$$L = B/2 + d/12$$

where:

$$B = \text{Bearing width}$$

$$d = \text{Cone bore}$$

$$R_a = \frac{1}{2} \text{ neck O.D.}$$

After D_E and L have been determined, the maximum roll neck bending stress can then be calculated by the following equation:

$$\sigma = \frac{10.2 \times SF_{(\max.)} \times L}{[2 \times (D_E)^3]}$$

where:

$$\sigma = \text{Maximum bending stress daN/mm}^2$$

$$SF_{(\max.)} = \text{Maximum mill separating force daN}$$

$$L = \text{mm}$$

$$D_E = \text{mm}$$

$$10.2 = \text{Constant}$$

General guidelines for roll material selection, as a function of maximum bending stress, are given below. However, it is the mill designer's responsibility to make the final decision on roll material selection and acceptable stress limits:

Roll Material	Maximum Bending Stress
Cast iron	5.5 daN/mm ²
Alloy iron	9.6 daN/mm ²
Cast steel	10.3 daN/mm ²
Alloy cast steel	13.8 daN/mm ²
Forged steel	17.2 daN/mm ²
Forged alloy steel	20.7 daN/mm ²

For particularly highly loaded mills, Timken can run a FEA to better evaluate the true bending stress in the fillet radius area of the neck, where the bending stresses are highest. The final roll neck design is a compromise between reducing the distance between the bearing and roll face to reduce roll neck stress, and increasing the distance for better sealing and/or bearing width to build in more capacity.

BEARING SELECTION: DIMENSIONAL CRITERIA

The first step in making your bearing selection is to understand the bore and O.D. requirements relative to the roll and chock size. The cylindrical roller bearing offers maximized radial capacity, but requires a separate thrust bearing and needs larger internal bearing clearance. Alternatively, the tapered roller bearing accommodates both radial and thrust loads without the need for a separate thrust bearing. Careful consideration must be given to the advantages that can be offered by both the cylindrical and tapered bearing solutions before making a final selection.

Example:

Select either cylindrical or TQITS solution for a cold strip mill running at 1000 m/min. rolling speed, having a maximum backup roll body diameter of 1200 mm and 10 percent roll body turndown.

Step 1: Calculate minimum allowable roll neck diameter at 60 percent of maximum roll body diameter:

$$\text{Roll neck diameter (minimum)} = 0.6 \times 1200 \text{ mm} = 720 \text{ mm}$$

Step 2: Calculate maximum allowable bearing O.D. based on a minimum roll body diameter at 10 percent turndown

$$\text{Minimum roll body @ 10 percent turndown} = 0.9 \times 1200 = 1080 \text{ mm}$$

$$\text{Bearing O.D. (maximum)} = 1080 \text{ mm} / 1.075 = 1000 \text{ mm}$$

Step 3: Select bearing from product tables

For this cold mill example, both the TQITS type or cylindrical-type assembly are viable alternatives.

FOUR-ROW CYLINDRICAL ROLLER BEARINGS

Four-row cylindrical roller bearing assemblies are available in sizes up to the 1040 mm (40.94 in.) bore. The RX type is typically used in flat product mills where the bore size exceeds 300 mm (11.81 in.). The cylindrical bearing assembly is used in both hot and cold mills due to its high-speed and precision capabilities, as well as its high radial capacity within a given bearing envelope.

The fixed chock (normally at the operator side) requires an additional thrust bearing outboard of the cylindrical bearing assembly to absorb external thrust loads inherent in the rolling process (fig. 84). This thrust bearing often is a spring-mounted two-row TDIK assembly. The external bearing mounted in the drive-side chock is referred to as a locator bearing, since it is required to only position the chock relative to the roll neck. However, the same thrust bearing often is used at both ends of the roll for bearing commonality.

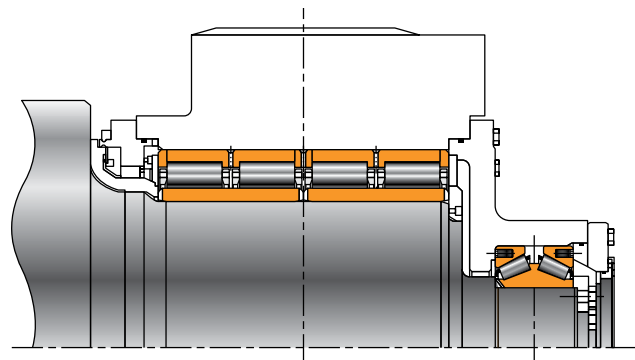

Fig. 84. Backup roll neck with four-row cylindrical roller bearing and thrust bearing.

RX configuration

The RX-style bearing (fig. 85) features two outer rings with an integral center flange. The two outermost flanges and the center flange are separate components. The cages are pin-type construction. The cage-roller assemblies are removed from the double-row outer ring for routine race inspections. Tapped holes are included in the cage rings for lifting purposes.

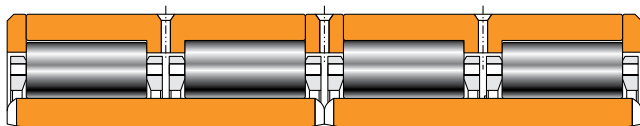

Fig. 85. RX construction.

The inner rings are normally a two-piece assembly except for very large sizes. The inner rings will typically include slots in both faces for dismounting of the rings. However, these rings can be provided without slots for specific applications where a static seal (O-ring) is used between the inner-ring face and adjacent roll neck components.

The RX bearing is generally supplied with semi-finished inner rings that allow finish grinding to a specified size after installation on the roll neck. This practice minimizes inner ring race to roll body eccentricity and permits tighter control of the bearing's mounted RIC.

Complete outer assemblies are interchangeable with inner ring assemblies and can be purchased separately.

In the cylindrical assembly part numbering (RX type): the first three or four digits represents the bore size (mm); RXS designates the outer assembly with the first three or four digits representing the DUR. ARXS is used to designate the inner ring set. The first three or four digits also represent the bore size in millimeters.

It also is important to note that the clearance designation (for example: CF1) will only be shown for the inner ring set (ARXS) and the complete assembly (RX).

Example:

Part number description of 900 mm bearing with customer finished clearance

Bearing Assembly: 900RX3444CF1

Inner ring: 900ARXS3444CF1

Outer Assembly: 989RXS3444

Optional bearing features

1. Oil-mist nozzle integration: The outer rings may be supplied with O-rings and oil-mist reclassifiers (fig. 86) for older mills using oil-mist lubrication. This eliminates the need for integrating the reclassifiers into the chock bore. The number of nozzles and holes per nozzle are dependent on the size of the bearing and required air/oil flow to the bearing assembly.

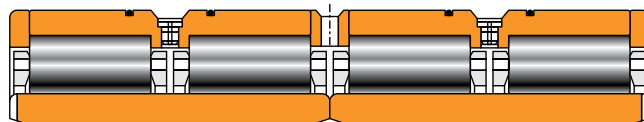

Fig. 86. RX bearing with integrated oil-mist reclassifiers and O-rings.

2. Four-row cylindrical roller bearing with tapered bore (RXK): Tapered bore versions of these assemblies are available and designated as RXK assemblies. The standard bore taper is 1:12, but a 1:30 taper is used on particularly wide assemblies. The tooling used for gauging the roll neck for proper taper and size includes sine bars and ring gages. These tools are required for all tapered bore roll neck applications.

Application considerations: RX bearings

1. Fitting practice: Cylindrical backup bearings used in strip rolling are mounted with a tight fit of the inner rings on the neck.

Straight bore inner rings must be heated (expanded) for installing on the roll neck (see page 162 for details).

2. RIC: Four-row cylindrical roller bearings are available with radial clearances according to DIN 620-4. Most long product applications use C4 or sometimes C3 radial internal clearance values.

The RIC is established by two parameters: the DUR and the IROD. The DUR is fixed for the bearing assembly, while the IROD is determined by the RIC value and also dependent upon the amount of tight fit of the latter. Both the DUR and IROD will have an inherent tolerance on their respective diameters. This results in a range of RIC.

Minimum DUR – Maximum IROD = Minimum RIC

Maximum DUR – Minimum IROD = Maximum RIC

3. Inner ring finishing options: The cylindrical assembly is supplied either with semi-finished inner rings for finish grinding after mounting, or finished inner rings and preset RIC.

In the case of finished inner rings, it is very important that the roll neck diameter is controlled for runout and that it is concentric with the roll body diameter.

FOUR-ROW TAPERED ROLLER BEARING WITH TAPERED BORE (TQITS)

TQITS configuration

The TQITS assembly (fig. 87) is a tapered bore roll neck assembly, with two single-row cones, one double-row cone, four single cups, and three cup spacers. All TQITS assemblies use a 1:12 bore taper and may be provided with either a uniform fit or a stepped fit. Bearing clearance (BEP) is established by controlling the widths of the three cup spacers. There are no cone spacers included with the TQITS assembly.

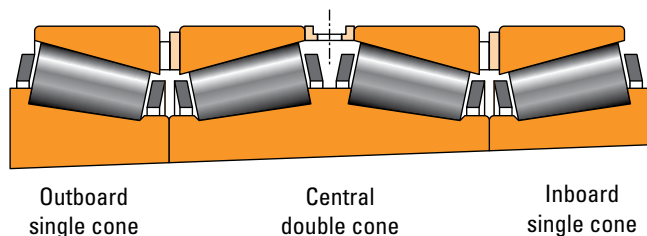

Fig. 87. TQITS construction.

The TQITS tapered roller bearing meets the requirements for high-speed mills. The tight fit and indirect mounting arrangement provide high stability between the cones and the neck. This results in excellent load sharing across the four rows of the assembly. Air-oil systems are typically used on more recent mills for lubricating these backup roll assemblies.

Minimizing backup roll runout is key to the mill's precision capabilities. The TQITS assembly is normally provided with tightly controlled runout to accommodate precision rolling requirements. Therefore, tight control of the concentricity of the roll neck to the roll body is important.

Optional bearing features

1. **Oil-mist nozzle integration:** See comments for cylindrical bearings on page 49.
2. **Higher precision:** Lower runouts (Timken code 359) are provided when end products require very small thickness tolerances.
3. **Sealed chock-bearing concept:** To improve the running surface accuracy of the inboard chock seal, the inboard cone outer rib can be extended (Type: TQITSE).

Application considerations: TQITS bearings

1. Cone fitting practice – stepped versus uniform bore:

- **Uniform bore:** The bores of the three cones are matched so that the fit on the roll neck is equal across the three cones. However, this approach results in contact pressures at the bore/neck interface that are higher for the outboard cones relative to the inboard cone (adjacent the fillet ring) because the cone cross sections are thicker at the central and outboard cones.
- **Stepped bore:** The outboard cone has the largest section thickness. In order to reduce the push-up force required to mount the assembly as a unit, the stepped bore-fitting practice is suggested to equalize the contact pressure for all three cones. When considering a stepped fit across the three cones, the total push-up force to install the bearing on the neck is reduced by approximately 20 percent.

2. **Axial clamping through cones:** The cones of the TQITS assembly must remain clamped after mounting to maintain proper fit and internal clearance.

3. **Fixed and float positions:** The cups of the TQITS assembly are only clamped on the fixed position of the mill (normally the operator side). On the floating side (fig. 88), the cups are permitted to float axially in the chock bore. Suggested axial gap between cup faces and adjacent chock shoulder/cover face is 3 mm (0.120 in.) on each side. The float side is not only permitted to float through the cups within the chock bore, but also through the chocks in the mill housing's window. This arrangement permits free expansion and contraction of the roll caused by variation in roll temperatures.

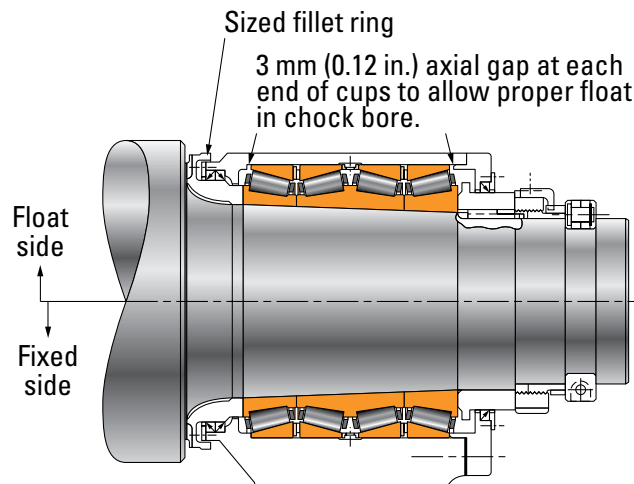

Fig. 88. TQITS bearing arrangement.

4. Tapered roll neck parameters: Hardness, surface finish and surface cleanliness.

- Roll neck surface hardness for tapered necks should be minimum of 27 to 37 HRC.
- Roll neck surface finish should be no greater than 0.80 μm (32 $\mu\text{in.}$).
- The TQITS assembly requires a very clean and dry roll neck to maintain the maximum grip due to the interference fit between the cone and neck.

5. Tapered roll neck measurement: Special tools are used for measuring roll neck taper, roll neck size and fillet ring length. These tools are essential to control proper assembly fit and mounted internal clearance, once the lead cone is seated against the fillet ring. Use of the sine bar and optional ring gage are covered on page 160.

6. Tools used for mounting and dismounting the TQITS assembly:

- **Mounting:** The bearing and chock assembly is mounted on to the roll neck using a hydraulic ring jack. The hydraulic ring jack is used to push the bearing up the tapered roll neck until the inner cone seats against the fillet ring.
- **Dismounting:** The roll neck must include axial and radial holes leading to the interface of the roll neck O.D. and each of the three cones. These holes supply high-pressure hydraulic fluid or oil to the cone bore/roll neck interface to release them from their tight fit on the neck. Each cone is released in succession starting with the outboard cone.

See the Bearing Storage, Handling and Installation section on pages 143-174 for further details on mounting and dismounting.

7. Roll interchangeability: Tight control of the large end cone bore diameter and of the roll neck size (controlled by the fillet ring length) permits interchangeability of the bearing from one roll neck to another.

8. Lubrication: The primary system used for lubricating the TQITS arrangements is air oil.

9. Fillet ring fit: For tapered bore bearing assemblies, the fillet ring should be tight-fitted on the roll neck with a minimum interference fit ratio of 0.00050 x bearing bore.

ROUGHING PLATE AND HOT FINISHING MILL

Roughing plate mills operate at slow speed and often are reversing, with several passes normally used to reduce the slab thickness. The mill stand requires extremely high separating forces in order to take the large thickness reductions on slabs that may be in excess of 300 mm (12 in.) in thickness. The rolling mill may use one or several roughing stands, typically of a 4-Hi configuration. Backup roll body diameters may be as large as 2500 mm (100 in.) and bearing bores as large as 1500 mm (59.06 in.).

Typically, the roughing plate and hot mill backup rolls use four-row tapered roller bearings.

The TQOW (fig. 89) has been selected and applied successfully over many decades on roll necks in all types of mills operating at low to medium speeds. The loose fit on the roll neck limits the acceptable mill to approximately 800 m/min. (2600 ft./min.). Timken also has experience with mills running at 1000 m/min. (3300 ft./min.), but this requires a more detailed review of the application (eg. provisions for bore to roll neck lubrication).

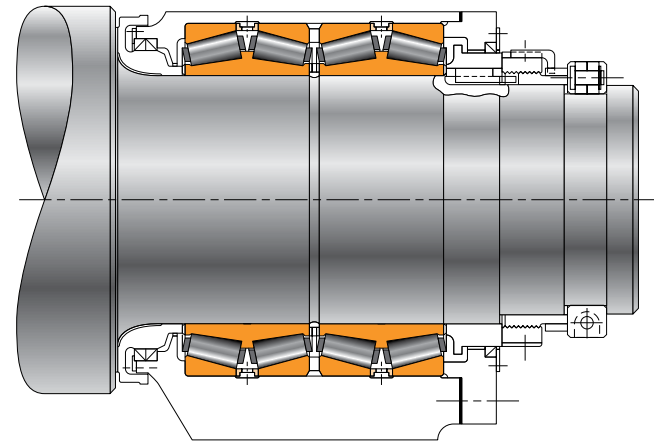

Fig. 89. Typical backup roll assembly with TQOW assembly.

The four-row cylindrical assembly (RX type) also might be a viable choice used in hot rolling, finishing stands.

OPTIONAL BACKUP ROLL BEARING FEATURES

The TQOW and the 2TDIW assemblies are the most popular four-row assemblies. However, there are variants to this basic assembly that may be specified to suit a specific application.

1. Radial holes through double cone's large rib (fig. 90): This feature is used with oil lubrication to feed the oil between the roll neck and cone bore. Plate mills with large bore bearings running under relatively low speed but with high radial load can benefit from this feature. Alternatively, the roll neck can be rifle drilled to lubricate the neck and cone bore contact.

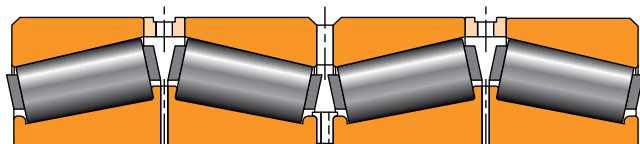

Fig. 90. TQOW bearing with oil holes through the large rib.

Plate mill backup roll bearings are subject to high loads. To minimize the contact stress between the roll neck and the bearing bore, spiral grooves in the cone bore are not suggested.

2. Increased neck diameter for extreme high-load applications: In heavily loaded backup rolls, which often run at slow speeds (example: plate mills or roughing stands), a larger neck diameter is needed to cope with the higher bending stress. Based on this need, the conventional heavy-duty bearing size, represented by bearing A (fig. 91), may not be suitable.

For these high-load applications, lighter section bearings are suggested (represented by bearing B in fig. 91) with approximately the same outer diameter as the heavy-duty bearings, but with a larger bore. These lighter bearings offer an increased neck-to-barrel ratio ($d/D \sim 68$ percent) and a smaller bearing width, that reduces the axial distance between the screwdown and the barrel face.

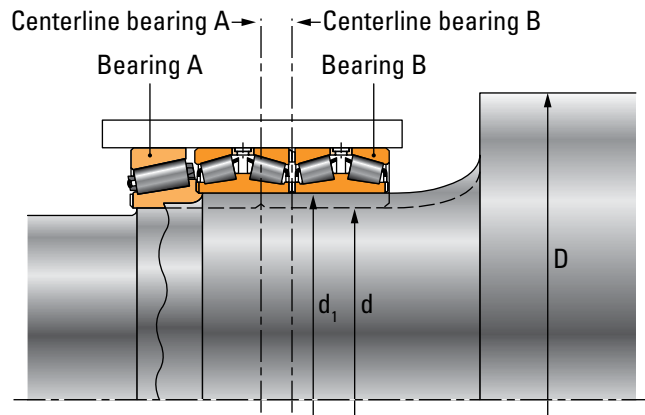

Fig. 91. Optimizing roll neck diameter.

The decrease in the bearing rating due to its smaller size is offset by incorporating one or more of the following product enhancements:

- Ultra-clean steel.
- Enhanced raceway profiles.
- Enhanced surface finish properties.

Another alternative to consider is the six-row tapered roller bearing instead of four-row. In this case, attention has to be given to the position of the bearing relative to the screwdown position.

INCREASED STRIP ACCURACY

There are several different mill configurations and control systems used to control both the longitudinal thickness of the strip and its transverse profile.

Controlling strip transverse profile: The strip's profile is primarily controlled by systems that are linked to the work roll (and also to the intermediate roll in the case of 6-Hi mills). These systems often are referred to as shape control.

Controlling strip longitudinal accuracy: An essential element in the cold rolling process is the roll gap adjustment system.

Most modern mills use a hydraulic adjusting system because it provides much faster and accurate control than the traditional electro-mechanical screwdown system.

One of the factors contributing to longitudinal thickness variation (also referred to as gage accuracy), is the eccentricity of the backup roll's rotation. It is influenced by both the bearing type and precision.

The gage accuracy can be improved by selecting either four-row cylindrical or four-row tapered bearings (TQITS type) that are tight-fitted on the roll neck. The tight-fitted inner race also eliminates the wear that can occur between the roll neck and bearing bore with the loose fitted bearing assembly.

Bearing precision for optimized gage accuracy is discussed in further detail on page 126.

BEARING SOLUTIONS: AXIAL POSITIONS

WORK AND INTERMEDIATE ROLLS

Both axial roll shifting and cross-rolling systems exert large thrust forces on work rolls and intermediate rolls. In these cases, a dedicated thrust bearing is needed (fig. 92). Axial positions always are mounted with a clearance fit in the housing to avoid any interference with radial load. The inner rings are loose fitted to the shaft to enable easy chock removal from the neck, and keyed to avoid rotation between the inner rings and the neck.

There are several bearing options to consider:

- Spring-loaded TDIK
- Spacer-type TDIK
- 2TSR assembly or
- Double-directional/heavy duty axial bearing (TTDWK or TTDFLK)

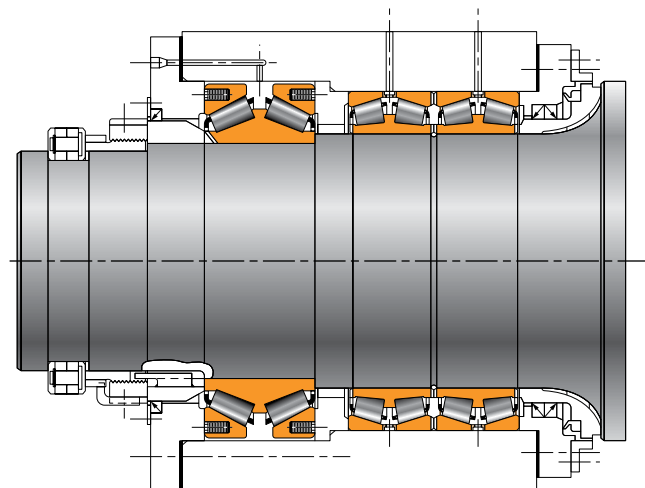

Fig. 92. Separate axial position accommodates high axial loads. Timken TDIK (double-row tapered roller bearing with spring-loaded cups).

TDIK WITH SPRINGS

Timken offers a variant of the standard TDIK assembly that includes spring-loaded thrust pistons integrated into both single cup large faces. These thrust pistons apply preload to the bearing assembly after final installation into the housing (fig. 92).

The TDIK version, with integrated springs, is considered for new mills to simplify the overall design, or for retrofitting to existing mills. This bearing has two primary advantages with respect to an externally preloaded TDIK mounting.

- The surrounding mounting arrangement is simplified since springs are no longer required in either the housing shoulder or follower. This minimizes the potential for either losing or damaging the external springs needed for the standard TDIK assembly.
- The spring size, stiffness and quantity per cup are selected to provide the appropriate preload force.

The gap between the spring-loaded cup face and housing is 0.15 mm (0.006 in.) and 0.30 mm (0.012 in.) on each side (fig. 93). This ensures spring preloading of the system and that springs remain with the bearing upon its removal.

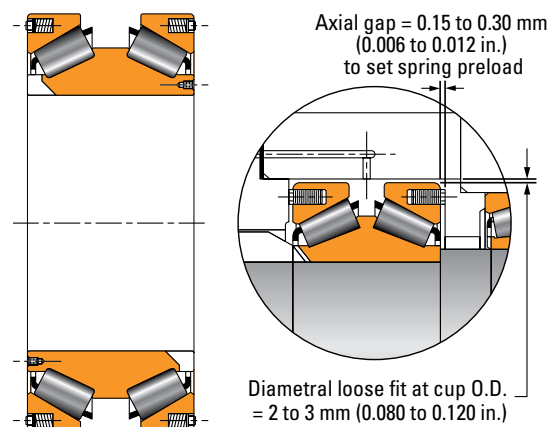

Fig. 93. TDIK with integrated springs; simplifies design and mounting.

SPACER-TYPE TDIK

Timken offers an alternative to the spring-loaded TDIK bearing. This bearing does not include the spring system, but instead uses a more conventional cup spacer to control bearing setting. Either a T-shaped or standard cup spacer can be used. The T-shaped cup spacer should be keyed to the chock cover to prevent rotation and the cups mounted tight within the T-shaped spacer.

This bearing assembly is typically set with a small axial clearance of approximately 0.05 mm (0.002 in.) endplay to minimize the risk of damage to the unloaded row.

2TSR THRUST BEARING ASSEMBLY

The 2TSR thrust assembly includes two single-row spherical bearings. Typically, the mill builder will mount two single-row bearings back-to-back in a cartridge (fig. 94). These TSR assemblies are best suited for applications where accommodation of heavy roll bending and high misalignment is required. These assemblies are capable of handling misalignment between the inner and outer ring of up to 2.5 degrees in either direction. Spring preload is used in the same manner as the spring-loaded TDIK bearing.

Bearing outer rings must be mounted with a generous loose fit to insulate them from radial loads and allow axial float. This avoids transmitting radial loads to the bearing under bending conditions.

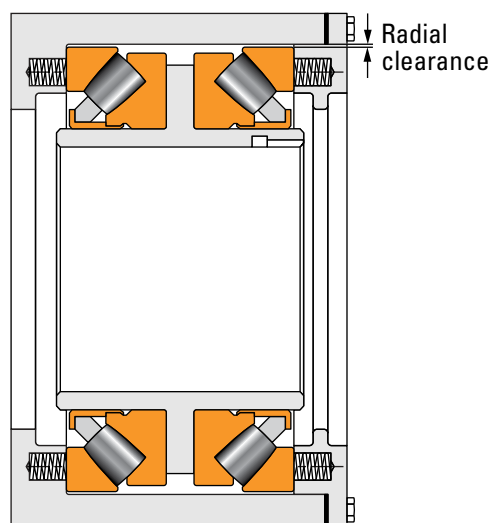

Fig. 94. Double-directional 2TSR.

DOUBLE-DIRECTIONAL, HEAVY-DUTY AXIAL BEARINGS (TTDWK OR TTDFLK)

For strip mills that generate particularly large thrust forces, such as cross rolling systems, the double-directional axial tapered roller bearing assembly should be considered. The TTDWK (fig. 95) bearing includes two flat washers – one on each side and one double-race thrust ring at the center of the bearing, as well as two sets of rollers that are retained as a unit in a pinned cage.

The TTDFLK (fig. 96), a variant to this TTDWK configuration, uses two tapered washers (one on each side) and a flat, double-race thrust ring at its center.

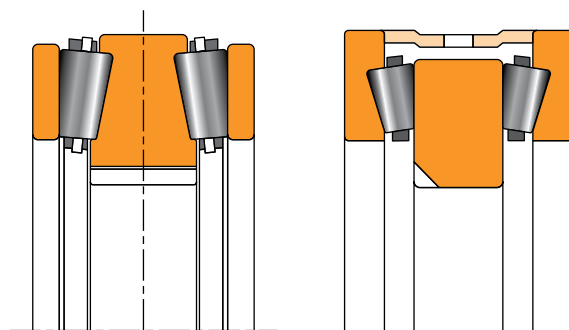

Fig. 95. TTDWK assembly (with flat outer washers).

Fig. 96. TTDFLK assembly (with flat double inner).

The TTDWK offers a narrower width for identical bearing capacity due to its center-tapered race design.

Roll neck mounting: A spring mounting (figs. 97 and 98) for the flat races is normally used to provide proper seating force on the unloaded row of rollers (similar to the TDIK mounting).

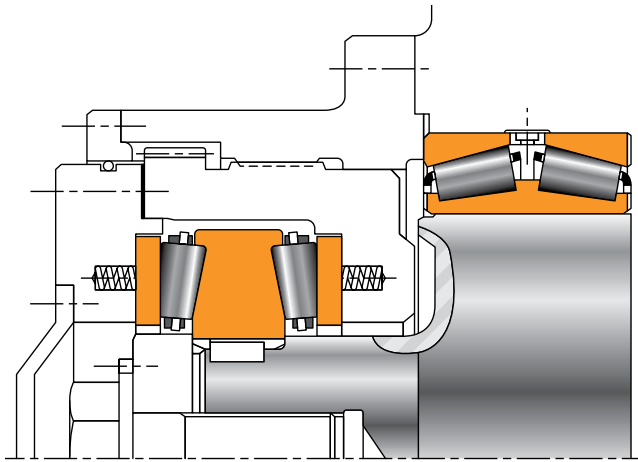

Fig. 97. TTDWK thrust assembly typical mounting.

The TTDFLK thrust bearing assembly can be provided with an outer spacer. However, it is generally preferred to include a spring mounting in the chock shoulders to ensure the rollers of both rows remain properly seated.

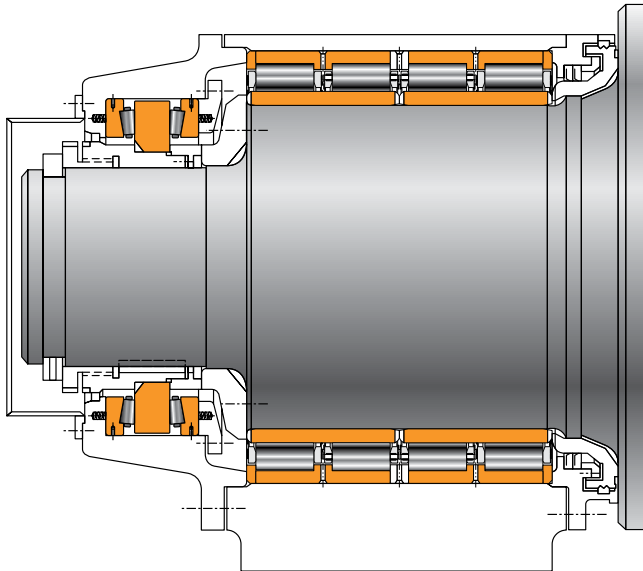

Fig. 98. TTDFLK thrust assembly typical mounting.

ANGULAR-CONTACT BALL BEARING ASSEMBLY



For higher rolling speeds and light axial loads, the angular-contact bearing is commonly used to accommodate the thrust loads. As the angular-contact ball bearing type can only accept axial loads in one direction, they are used in pairs (fig. 99), with the contact angles mounted in opposite directions. Typical applications include foil mills and high-speed wire mills where they are used at the axial position in combination with a four-row cylindrical roller bearing at the radial position (fig. 100).

Fig. 99. Angular-contact ball bearing assembly.

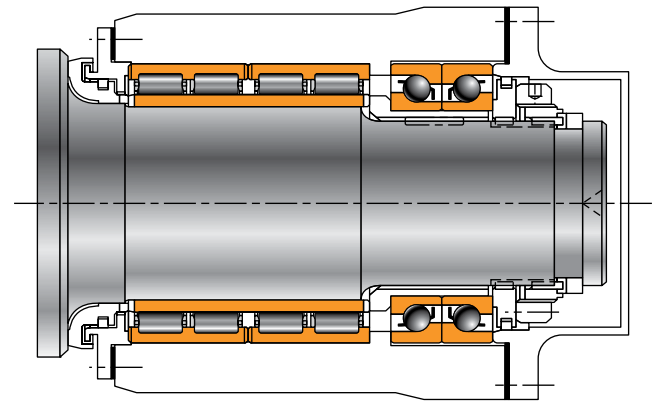

Fig. 100. Angular-contact ball bearing assembly typical mounting.

BACKUP ROLL

When the backup roll employs either a cylindrical roller or an oil-film type bearing, a separate heavy-duty thrust bearing must be incorporated at the fixed side of the mill (normally the operator side). At the float side, the same thrust bearing may be used for commonality of design, but a lighter-duty locator bearing, such as a deep-groove ball bearing also is suitable.

In conventional mills (with no roll shifting or crossing), these thrust loads are typically the result of roll misalignment or a wedge profile on the incoming strips.

If the design of the mill includes roll crossing or roll shifting, these thrust loads may be significantly higher and require higher capacity thrust bearings to be selected.

TDIK FOR FIXED CHOCK

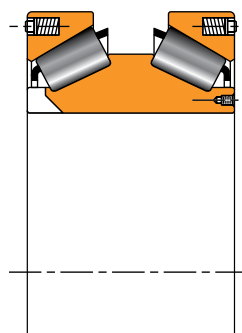

The thrust bearing most often used in the fixed chock is the TDIK assembly. This bearing assembly will absorb external roll thrust in either direction and normally features a spring preloaded system (fig. 101). The spring force needed to seat the rollers against the large rib is typically less than two percent of the bearing's axial capacity, C_{a90} .

Fig. 101. TDIK assembly.

The standard TDIK assembly includes one double cone and two single cups.

The double cone is typically keyed to the roll neck on the outboard face. The keyways are provided in both faces of the double cone so that the bearing assembly can be reversed to extend its life if roll thrust is predominately in one direction during mill operation. While keyways are normally located in the faces, bore keyways also can be provided.

The fitting practice for the outer rings is always loose to ensure that the thrust bearing is only absorbing thrust loads and is isolated from radial loading. This loose cup fit should have a 2 to 3 mm (0.08 to 0.12 in.) clearance on diameter. The fitting practice for the inner rings (cones) is a loose fit on the roll neck with positive axial clamping.

LOCATING BEARING FOR FLOAT CHOCK

The cylindrical assembly at the float side of the mill also requires a thrust bearing to locate and retain the chock on the roll end. This locator bearing is not required if spreader bars are used to locate the float chock relative to the fixed chock. A deep-groove ball bearing is usually sufficient to provide axial location of the float side chock as noted in the illustration below (fig. 102).

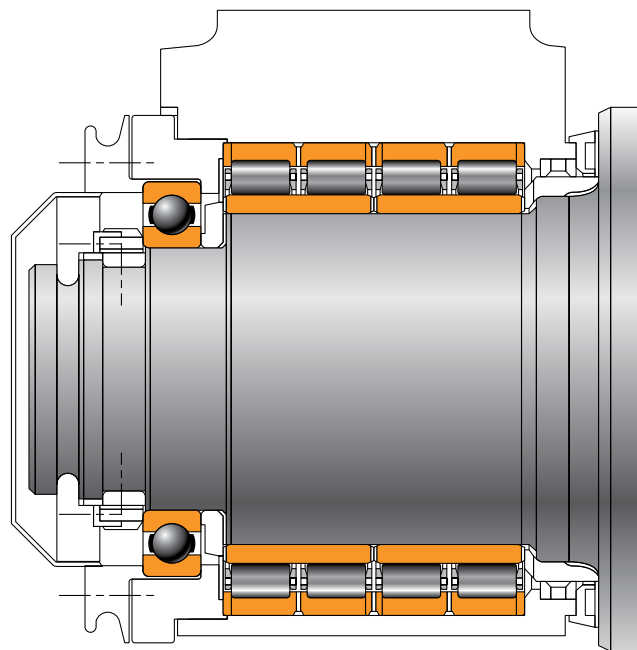

Fig. 102. Float chock with deep-groove ball bearing at thrust position.

SCREWDOWN SYSTEMS

The operating speed of screwdown systems is very low during gap adjustment. Modern mills will either use the electromechanical screwdown system in conjunction with a hydraulic roll force cylinder, or will solely use the hydraulic roll force cylinder. The primary benefit of hydraulic roll force cylinders is their fast response time compared to the electro-mechanical screwdown systems, but the mechanical system gives more precise location with small displacements.

When the mechanical system is used, the screwdown thrust bearing is applied between the main mill screw and top chock. The loads transmitted through these screwdown bearings are extremely high, typically equivalent to half of the mill's separating force that can be several thousand tons. The operating speed is basically zero as the screw's rotational speed is very slow during adjustment. For this reason, the bearing selection is based on its static capacity (C_0).

Timken offers a wide range of these heavy-duty thrust bearings as follows:

TTHDFLSX

The traditional screwdow assembly uses a flat-bottom race and a tapered-top race. The top race is provided with a special convex profile (fig. 103) to match the end of the screw or its aligning washer. Both upper and lower races are supplied with threaded lifting plugs to facilitate handling. These assemblies are a full-complement design (cageless) to maximize bearing capacity.

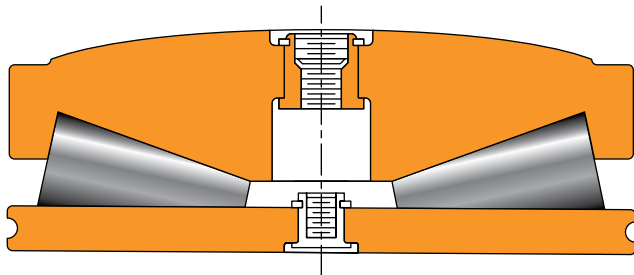

Fig 103. TTHDFLSX convex upper race design.

TTHDFLSV

The TTHDFLSV assembly is the same as the above TTHDFLSX except that the upper race has a concave profile (fig. 104) to match the screw or its aligning washer. This design is less common than the convex version due to the thinner sections of the tapered race.

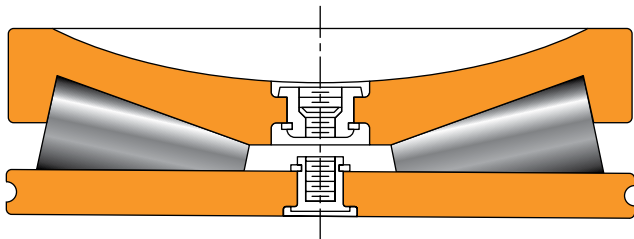

Fig. 104. TTHDFLSV concave upper race design.

APPLICATION CONSIDERATIONS: SCREWDOWN BEARINGS

- 1. Bearing cartridge:** The bearing is mounted in a cartridge primarily to contain the lubricant needed for the assembly, but also to unitize the entire bearing assembly.
- 2. Tapered-bottom race:** If the bottom race is tapered (TTHDSX) as illustrated in fig. 105, then a 3 mm (0.120 in.) radial clearance is suggested relative to the O.D. of the race to ensure that the bottom race will self-align with respect to the upper tapered race. Otherwise, the roller ends will not be properly seated against both the upper and lower large ribs simultaneously. A piloting bushing is pressed into the cartridge and is used for centering the upper race and rollers. The bottom race will be centered by the upper race and roller set.
- 3. Flat-bottom race:** If the bottom race is flat (TTHDFLSX), then apply close fit as per fitting practice guidelines. The flat race permits radial self-aligning of the rollers and conical washer.
- 4. Sealing:** An oil seal is mounted in the upper plate that is bolted to the cartridge to keep contaminants from entering the bearing assembly.
- 5. Lubrication:** Adequate lubrication is maintained by filling the bearing with high-quality EP grease having a viscosity of approximately 450 cSt at 40° C (104° F).

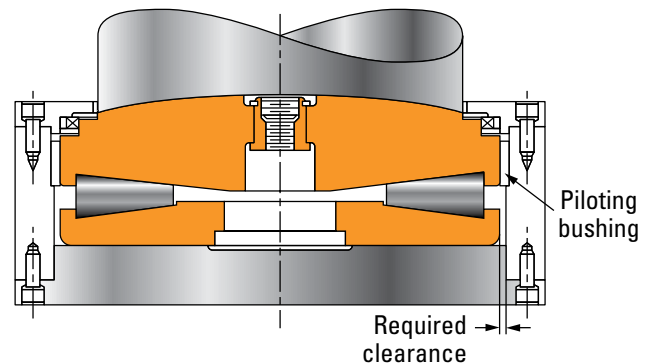

Fig. 105. TTHDSX assembly with tapered-bottom race.

AUXILIARY EQUIPMENT

MAIN MILL DRIVE AND PINION STAND GEARBOXES

Mill drives are generally comprised of a speed reducer or increaser and a pinion stand. The pinion stand splits the drive into two counter rotating elements for connecting to the mill rolls. The reducer and pinion stand can be either separate units or a single, combined unit.

These drives can range in power from a few hundred to more than 10000 kW at output speeds up to 1200 RPM or more. For example, a light gage aluminum mill may operate at a higher speed while a hot-roughing steel mill would operate at a lower speed.

BEARING SELECTION

There is tremendous variety of gearbox configurations, including single reduction and double reduction. Despite the variations, all these gearboxes are considered heavy-duty and are designed for high reliability, with a typical target bearing L_{10} life of 50000 hours or more (see Bearing Life Calculations and Related Analysis section on pages 67-93 for more details).

Single-helical gearing

Single-helical gears (fig. 106) generate opposing thrust loads that must be absorbed by one of the bearings supporting each gear shaft. The bearing configuration is typically designed so each shaft in the gearbox has one fixed and one float position bearing. Single-helical gearing is generally used in the smaller mill drives.

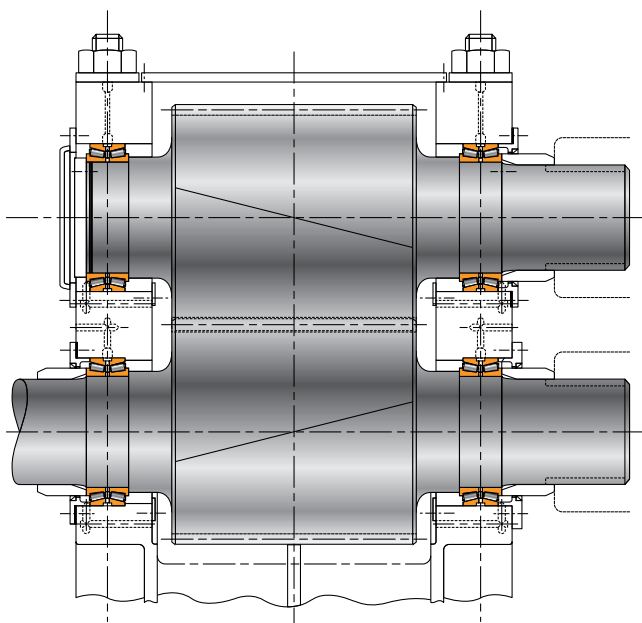

Fig 106. Single-helical gearbox.

Double-helical gearing or herringbone

Double-helical gears (fig. 107) do not generate external thrust loads. The thrust loads from one half of the gear are cancelled out by those of the other half. A requirement of these gears is the freedom to allow mating gears to align themselves axially to allow loading across both halves of each gear.

The resulting bearing selection must fix one end of only one shaft and allow all other positions to float. The fixed bearing positions the whole gear and shaft system within the gearbox housing. Double-row tapered roller bearings often are selected at the fixed position due to the combined radial and thrust load capacity.

The floating bearings must accommodate the relative axial movement between the shaft and housing. The cylindrical roller design supports relatively heavy loads and permits free axial displacement. Spherical roller bearings, or TDO tapered roller bearings may be used if the sliding pressures between the outer ring and housing bores are not excessive.

Main drives for larger mills may be subject to high-inertial load accelerations and decelerations. The speed changes that originate at the mill rolls are amplified by the reducer that is in the drive system. As a result, the drive input shaft will see even higher speed changes in the same time span.

The above high-inertial load situation can give rise to torsional vibration in the drive as the many elements involved combine to create a complex torsional spring-mass system. In extreme cases, this can result in torque reversals.

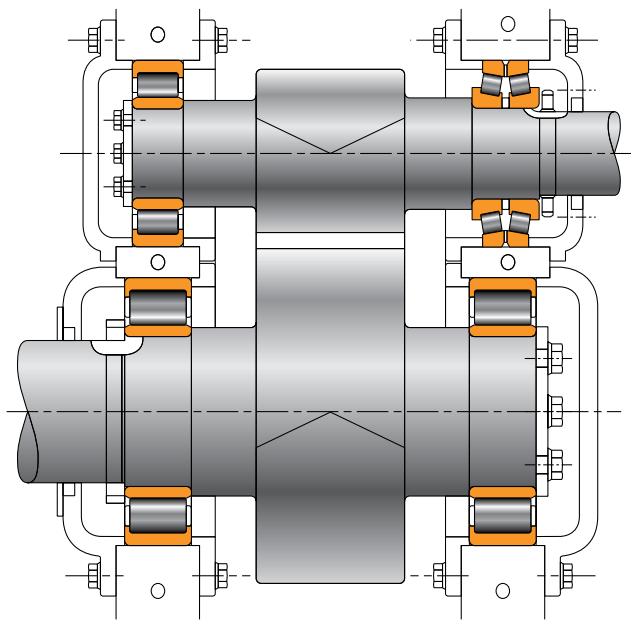

Fig 107. Double-helical gearbox.

The factors on the previous page mean that bearings must be selected with consideration of cage strength and internal clearances.

Cage strength must be sufficient to withstand roller impact outside of the load zone while simultaneously accommodating the inertial loads originating from the rollers within the load zone.

Application considerations

The gearing type and the operating parameters of the mill are important when selecting bearings for these drives. The following factors must be considered: loads and speeds, shaft and housing fits, operating temperature range and lubrication.

1. **Operating conditions:** The bearing loads are a function of the gearbox torque that is being transmitted and are a result of the tangential, separating and axial forces developed at the gear meshes. The formulae for deriving these forces are included in the Bearing Life Calculations and Related Analysis section on pages 67-93. The specific gearing type results in quite different bearing requirements. The operating speed range and load cycles are required to determine fatigue life time, heat generation, lubricant flow rate and bearing setting.
2. **Fitting practice:** Shaft and housing fits influence bearing performance and must be selected with care to give correct and adequate journal support. By convention, inner rings are tight fitted and outer rings loose fitted, although each application must be reviewed on its merits. Contact your Timken engineer for more information.
3. **Lubrication:** As with all rolling-element bearings, the lubricant specification is paramount when striving to maximize performance. Mill drives conventionally utilise the gear lubricating oil for the bearings. The lubricant must have adequate viscosity at the operating temperature to generate an EHL and supplied at a rate to aid heat transfer.
4. **High speed:** For high-speed applications, double outer rings of tapered roller bearings are available with a locking pin recessed in the outer ring. This eliminates any creep of the outer ring in its housing, as well as the accompanying wear and debris. The recess is combined with a lubrication hole and is used with a hollow dowel pin.
5. **High acceleration and deceleration:** Regardless of gearing type and gearbox configuration, there are many factors in addition to basic radial and thrust capacity that must be considered when selecting bearings, including high inertial loads and their impact on vibration in the drive.
6. **Operating bearing clearance:** Selection also must consider the influence of operating clearances. A low operating clearance is beneficial as it increases the load zone and reduces the number of unloaded rollers free to impact the cage. Smaller clearances also reduce the backlash in the drive system and give better guidance to the unloaded rolling elements within the bearing.

The factors that most impact the bearing's operating clearance include:

- The fitting practice that is used, as tight fits result in reduced clearances.
- The temperature gradient that will exist across the bearing from inner ring to outer ring is largely a function of operating speed more so than load.
- The desired minimum running clearance at normal operating temperatures.

Radial, cylindrical and spherical roller bearings require a positive running clearance, but tapered roller bearings can operate well with much smaller clearance up to light, preloaded condition.

Cylindrical and spherical roller bearings' initial radial clearances are preset by the manufacturer. The clearances for these bearings are normally selected from industry standard ranges, however, special clearances are available to suit particular applications.

The initial clearance of two-row tapered roller bearings can be further optimized to obtain the desired running clearance. The axial clearance in a tapered roller bearing is adjustable. The most accurate method is to custom grind the bearing spacer at the time of assembly based on actual component and seating dimensions. This removes the effect of tolerances for shaft diameter, bearing bore and spacer width on the final mounted clearance (or preload), leading to a narrower setting range.

PAY-OFF AND REWIND REELS

Strip mills or process lines generally include a coil process as part of the rolling or processing function. Therefore, they have a minimum of one reel to either pay-off or rewind the strip. These reels go by a variety of names, including uncoilers, unwinders, coilers, winders and tension reels.

An integrated hot-strip mill may have up to three heavy-duty reels to allow continuous or semi-continuous rolling. Each reel uses a mandrel to support the coil.

Two common reel styles are twin-stub mandrels and full-face expanding mandrels.

Twin-stub mandrels are mounted on each side of the coil and only engage the coil bore at each end. The stub mandrels can be either solid cones with drive keys or the expanding type, and are generally used for light-gage aluminum strip and foil mills because the coil itself is built upon a steel tube. This facilitates coil handling that does not support the coil on its outside diameter, thus reducing the chance of damage to the soft and often surface-critical material.

Full-face expanding mandrels engage the full length of the coil. The expand and collapse function allows the coil to be loaded and unloaded (collapsed) but also to transmit considerable torque (expanded). These reels are prevalent in hot- and cold-strip mills where strip tensions and coil weights are relatively high. When coil weights are high, as for large and wide steel strip, an outboard bearing is usually added in order to minimize mandrel deflection (fig. 108).

The expand and collapse feature in modern mills is actuated by a rotary hydraulic cylinder mounted on the back of the mandrel shaft. The mandrel shaft is usually incorporated into the drive gearbox as the output shaft. A variation on this utilizes a gearbox with a hollow output shaft that the mandrel assembly is plugged into. This design facilitates rapid change of the mandrel assembly.

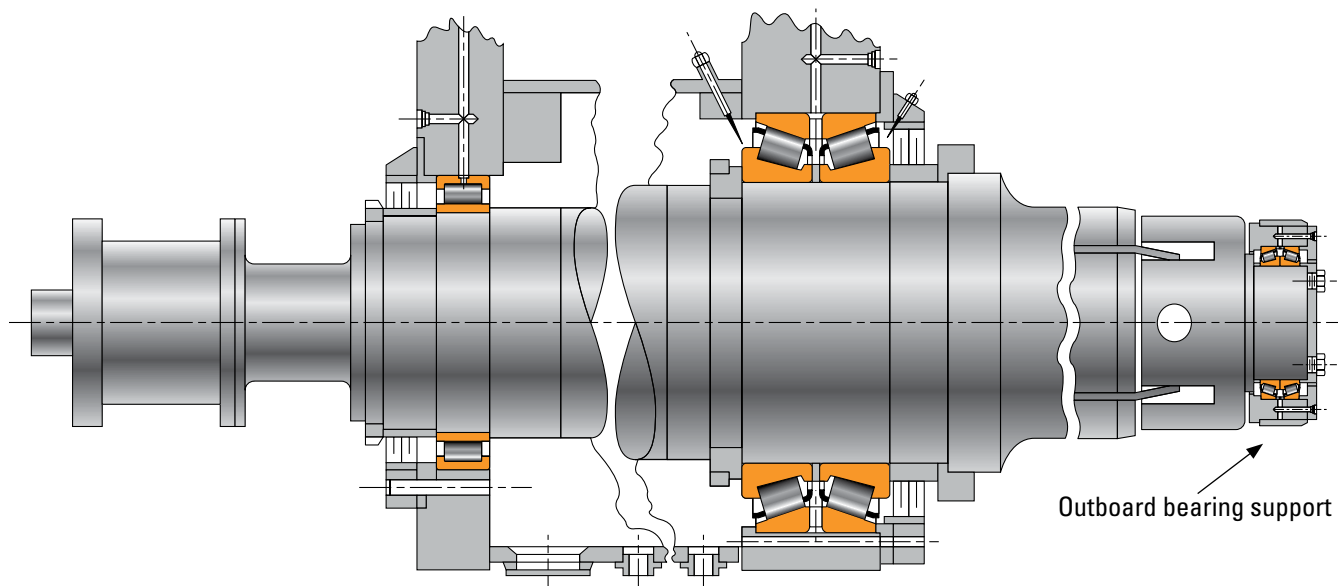

Fig. 108. Full face mandrel with outboard bearing.

APPLICATION CONSIDERATIONS: REELS

Duty cycle

The duty cycle of bearings in pay-off and rewind reel applications needs special consideration as the load/speed are constantly changing during coiling and uncoiling. The pay-off reel starts with the full coil weight but at low speed. As the coil is rolled, the coil weight steadily decreases while the speed steadily increases. The opposite applies to a rewind reel. The weight of the mandrel shaft also must be included with the loads resulting from the strip tension.

Load and life analysis for the bearings can be done in one of two ways. The easiest method is to use weighted average coil weight and speed values. A selection of coil weight and associated diameters and speeds also can be used. These must represent the conditions at various times during the rolling of a coil and are used to calculate a mean life for the bearings. Refer to the Bearing Life Calculations and Related Analysis section on pages 67-93 for bearing load and life calculations.

Bearing selection

Bearing selection criteria is similar to main drives, including the normal considerations for fixed and float positions, operating clearances and speed capabilities. However, the loading of these bearings needs special consideration. Preferred bearing arrangements include:

- Two-row tapered roller bearings in both fixed and float positions.
- Two-row tapered roller bearings in the fixed positions and cylindrical roller bearings in the float positions.
- The two-row TDO-type bearing is the preferred selection for the front (closest to coil) position on the output/mandrel shaft because of high radial and axial load capability and high stiffness. Spherical bearings also are used for fixed and float positions where significant shaft deflections need to be accommodated.

SHEARS AND SHEAR DRIVES

The operating conditions of shears and their drives can generate challenging loading conditions for bearings. Special attention is required when making bearing selections.

There are a variety of shear designs used in rolling mills and process lines. Most are either stationary shears or flying shears. A stationary shear requires that the material being cut is stationary, whereas a flying shear makes cuts while the material is moving.

HIGH-SPEED STATIONARY SHEARS

These shears typically use a low power drive motor that continuously drives a flywheel through a gearbox. The flywheel is connected to the shear by a clutch and brake. When a cut is made, the clutch is engaged and the shear draws energy from the flywheel. Engagement and disengagement of the clutch only takes a fraction of a second and results in a shock load being transmitted back through the drive. Bearing loads are relatively high for a brief period of time.

FLYING SHEARS

The type of flying shear considered here is the drum shear, but similar considerations apply to other types as well. The drum shear is comprised of two parallel drums with one located above the strip and one below the strip (fig. 109). The drums are a fixed distance apart and each drum is fitted with either one or two blades positioned 180 degrees from each other. The drums are geared together so that their rotation causes the blades to come together and make a cut. They are driven by a high-power motor through a gearbox. The rotational speed of the drums at the time of the cut is controlled so that the blades are moving at the same speed as the material being cut. However, the shear and its drive are static between cuts.

Operation of the shear involves rapid acceleration of the drums from the parked position up to a speed that matches blade speed to material speed. For single-blade drums this must occur within less than one revolution of the drum. For two-bladed drums, it must occur in less than one half rotation.

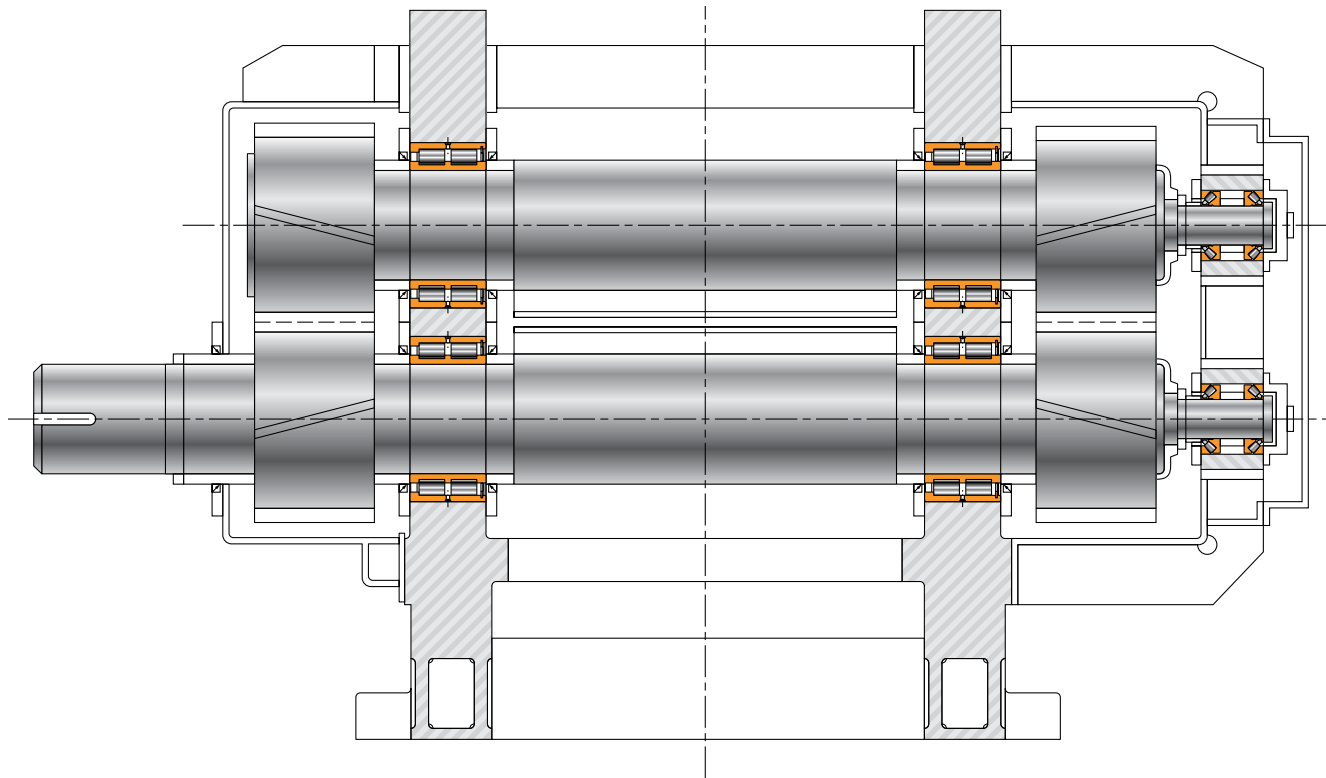

Fig. 109. Drum type flying shear.

APPLICATION CONSIDERATIONS: SHEARS

- 1. Operating conditions:** The duty cycle on the bearings involves rapid changes in speed and load that can be higher than those seen in the main mill drive. These can result in high-inertia/impact loads on the bearing components particularly between the retainers (or cages) and the rolling elements.
- 2. High acceleration and deceleration:** It's important to note that accelerations and decelerations originating at the shear itself are amplified as they are transmitted back through the drive gearbox (reducer) to the input shaft. Therefore, it is the input shaft bearings that will see the most abrupt speed changes (acceleration and deceleration effect).

Bearing selection must consider high-inertial and impact loads within the bearing itself. Special attention needs to be paid to the bearing cage, especially on the input shaft. In addition, bearing internal clearances should be as low as possible in order to lower these inertial/impact loads and reduce the chance for roller skidding during the light load portions of the duty cycle.
- 3. Bearing selection:** Bearings used in the shear itself do not normally experience speed changes that require special considerations, but bearing loads can be very high at the instant the cut is made. Multi-row tapered and cylindrical roller bearings are generally used in the high-load positions. Heavy-duty drum shears often use multi-row, full-complement cylindrical roller bearings in order to maximize capacity within a given space. These bearings require a separate thrust bearing that often is incorporated into the axial adjustment mechanism for the drums. Tapered, spherical and cylindrical roller thrust bearings can all be used in this position.

TABLE ROLLS

All rolling mills and process lines contain rolls that support, pinch, deflect or tension the material being processed (figs. 110 and 113). These rolls can be solid or hollow, driven, or non-driven and there are a variety of bearings and bearing combinations that can be used to support them. The most commonly used bearings are spherical and two-row tapered roller bearings. Cylindrical roller bearings also are used but only on float positions and are paired with a tapered or spherical roller bearing in the fixed position.

The spherical roller bearing offers high radial capacity, moderate thrust capacity and can accept high degrees of misalignment. A practical guideline for thrust-load capability is that it should not exceed one-third of the applied radial load. Thrust loads greater than this introduce the risk of unloading one of the two rows of rollers. The misalignment capability varies depending on the series.

The flexibility of the spherical roller bearing for these applications is further enhanced when they are mounted in a housed unit or pillow block (fig. 111). The housed unit assembly offers a unitized and sealed assembly that can be used with grease or oil lubrication and that can be configured for use in a fixed or float position. The unitization facilitates installation.



Fig. 110. Hot-strip mill roller tables.

For particularly demanding applications such as reheat furnace discharge tables, the Timken solid-block housed units can be considered. They offer spherical roller bearings mounted in extremely strong one-piece housings.

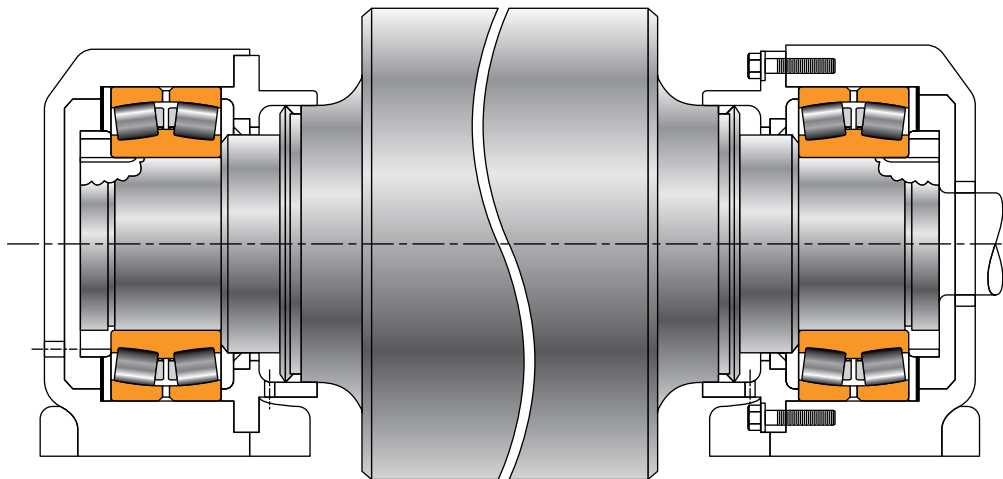

Fig. 111. Table roll supported by spherical roller bearings mounted in a housed unit.

The two-row tapered roller bearing offers higher load capacity, but it's wider for a given bore size than the spherical roller. For table roll applications, the two-row tapered roller bearings is commonly used as an AP™ type assembly (fig. 112). The AP assembly is supplied with seals and seal wear rings together with a wide range of mounting accessories. All AP bearings feature case-carburized rings and rollers that offer higher fracture toughness than through-hardened material. This can be a consideration when significant impact loads are anticipated.

Tapered roller bearing solutions do not offer the same tolerance to misalignment as the spherical roller bearings. If the roll deflection is such that the slope of the shaft through the bearing exceeds 0.5 mrad then the tapered roller bearing is generally not suggested.

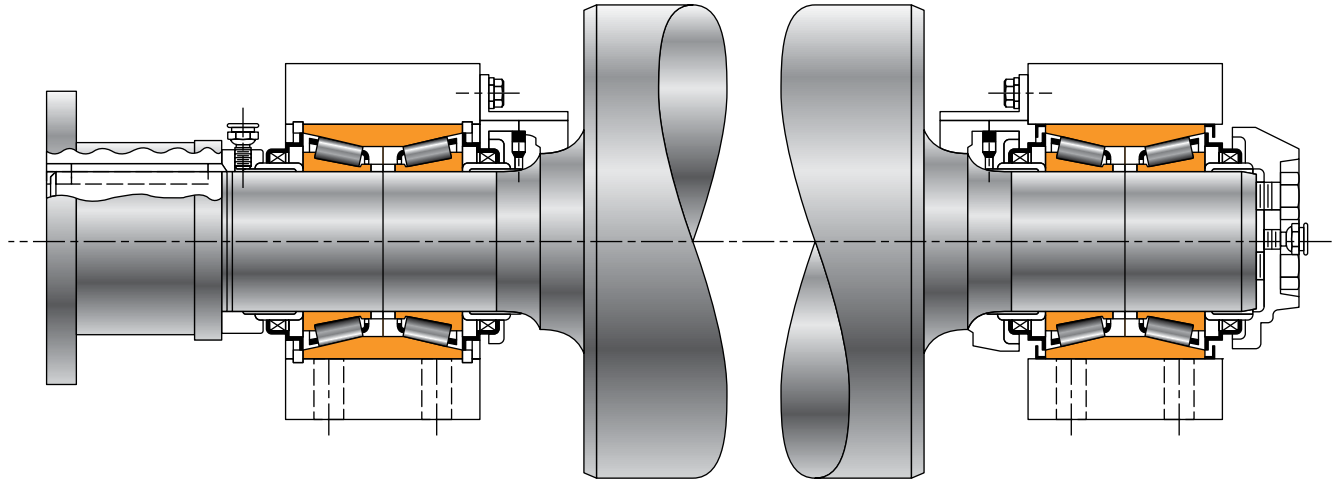

Fig. 112. Table roll supported by AP™ type tapered roller bearing assemblies.



Fig. 113. Hot-strip mill transfer roller table.

BEARING LIFE CALCULATIONS AND RELATED ANALYSIS

The following topics are covered in this section:

- Summary of symbols.
- Fatigue life.
- Bearing ratings.
- Applied loads.
- Bearing life equations.
- Bearing internal clearance.
- Advanced analysis.

NOTE

Further information can be found in the Timken Engineering Manual (order no. 10424).

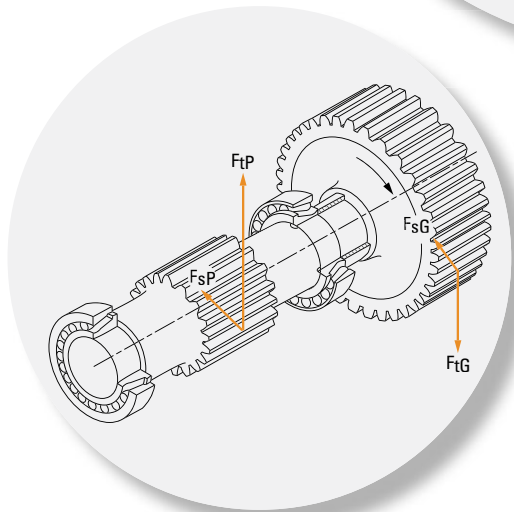
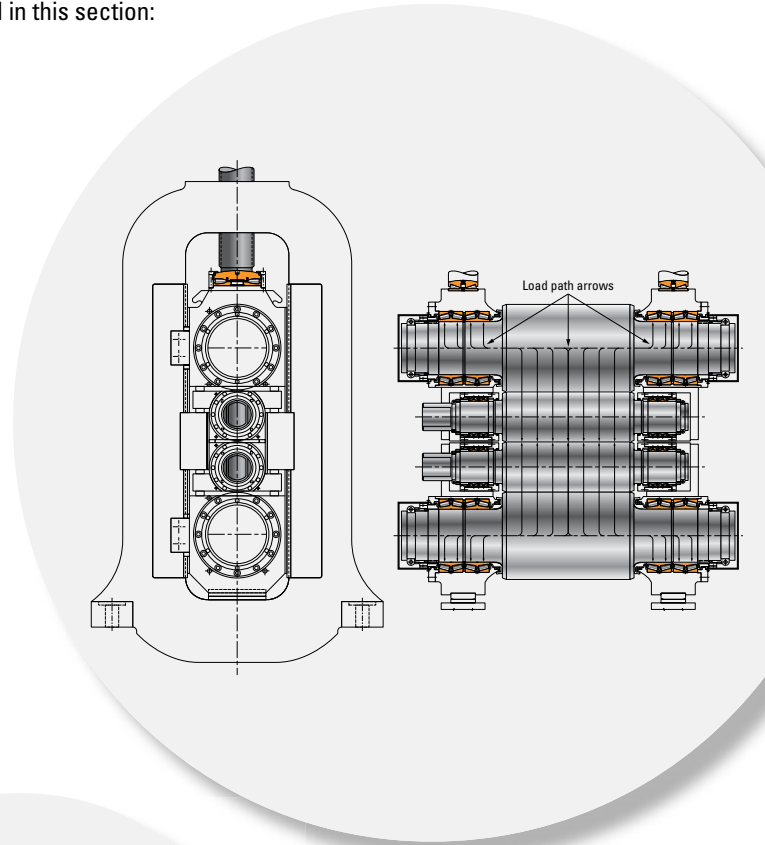

SUMMARY OF SYMBOLS USED TO DETERMINE APPLIED LOADS AND BEARING ANALYSIS

Symbol	Description	Units (Metric/Inch System)	Symbol	Description	Units (Metric/Inch System)
a_1	Reliability Life Factor	unitless	F_{aP}	Thrust Force on Pinion	N, lbf
a_2	Material Life Factor	unitless	F_S	Separating Force on Gear	N, lbf
a_3	Operating Condition Life Factor	unitless	F_{sG}	Separating Force on Gear	N, lbf
a_{3d}	Debris Life Factor	unitless	F_{sP}	Separating Force on Pinion	N, lbf
a_{3k}	Load Zone Life Factor	unitless	F_t	Tangential Force	N, lbf
a_{3l}	Lubrication Life Factor	unitless	F_{te}	Tractive Effort on Vehicle Wheels	N, lbf
a_{3m}	Misalignment Life Factor	unitless	F_{tG}	Tangential Force on Gear	N, lbf
a_{3p}	Low-Load Life Factor	unitless	F_{tP}	Tangential Force on Pinion	N, lbf
b	Tooth Length	mm, in.	γ_G	Bevel Gearing – Gear Pitch Angle	deg.
C_1	Basic Dynamic Load Rating of Timken Single-Row Assembly at One Million Revolutions Converted from its C_{90} Rating, Which is Based on 90 Million Revolutions	N, lbf	γ_P	Bevel Gearing – Pinion Pitch Angle	deg.
$C_{1(2)}$	Basic Dynamic Load Rating of Timken Double-Row Assembly at One Million Revolutions Converted from its C_{90} Rating, Which is Based on 90 Million Revolutions	N, lbf	H	Timken's Geometry Dependent Factor For C_{90} Rating Equation	unitless
$C_{1(4)}$	Basic Dynamic Rating of Timken Four-Row Assembly at 1 Million Revolutions Converted from its C_{90} Rating, Which is Based on 90 Million Revolutions	N, lbf	H	Power	kW, hp
C_{90}	Basic Dynamic Radial Load Rating of a Single-Row Bearing for an L_{10} of 90 Million Revolutions or 3000 Hours at 500 RPM	N, lbf	i	Number of Rows of Rollers in a Bearing	unitless
$C_{90(2)}$	Basic Dynamic Radial Load Rating of a Double-Row Bearing for an L_{10} of 90 Million Revolutions or 3000 Hours at 500 RPM	N, lbf	K	Tapered Roller Bearing K-factor; Ratio of Basic Dynamic Radial Load Rating to Basic Dynamic Thrust Rating in a Single-Row Bearing	unitless
$C_{90(4)}$	Basic Dynamic Radial Load Rating of a Four-Row Bearing for an L_{10} of 90 Million Revolutions or 3000 Hours at 500 RPM	N, lbf	L	Distance Between Bearing Geometric Center Lines	mm, in.
C_{a90}	Basic Dynamic Thrust Load Rating of a Single-Row Bearing for an L_{10} of 90 Million Revolutions or 3000 Hours at 500 RPM	N, lbf	L_{10a}	Adjusted Life of Bearing with 90 Percent Reliability for Given Condition...Multiplies Factors Such as A_{3l} and A_{3m} To L_{10}	hours
C_o	Basic Static Radial Load Rating	N, lbf	L_{10wt}	Weighted Life of Bearing Over Given Set of Conditions	hours
C_r	Basic Dynamic Radial Rating of Single-Row Bearing as Defined by ISO/ABMA Rating Equation for an L_{10} of One Million Revolutions	N, lbf	L_{10}	Bearing Life	millions of revolutions
d	Bearing Bore Diameter	mm, in.	L_{eff}	Roller Effective Length	mm, in.
D	Bearing Outside Diameter	mm, in.	M	Bearing Operating Torque	N-m, N-mm, lb.-in.
d_o	Mean Inner Ring Diameter	mm, in.	M_c	Timken Material Constant For C_{90} Rating Equation	unitless
D_h	Housing Outside Diameter	mm, in.	m	Gearing Ratio	unitless
D_{mG}	Mean or Effective Working Diameter of the Gear	mm, in.	n	Bearing Operating Speed or General Term for Speed	RPM
D_{mP}	Effective Working Diameter of the Pinion	mm, in.	n_G	Gear Operating Speed	RPM
D_o	Tapered Roller Bearing Outer Ring Mean Raceway Diameter	mm, in.	n_P	Pinion Operating Speed	RPM
D_{pG}	Pitch Diameter of the Gear	mm, in.	N_G	Number of Teeth in the Gear	unitless
D_{pP}	Pitch Diameter of the Pinion	mm, in.	N_P	Number of Teeth in the Pinion	unitless
d_S	Shaft Inside Diameter	mm, in.	P_a	Dynamic Equivalent Axial Load	N, lbf
D_{we}	Mean Roller Diameter	mm, in.	P_r	Dynamic Equivalent Radial Load	N, lbf
F_a	Applied Thrust (Axial) Load	N, lbf	R	Percent Reliability, Used in the Calculation of the A_1 Factor	unitless
F_{ac}	Induced Thrust (Axial) Load Due to Centrifugal Loading	N, lbf	T_X	Percent Time for Condition, See Weighted Life Formula	0 to 100 percent
F_{ae}	Net External Thrust Acting on the Shaft	N, lbf	γ	Dynamic Thrust (Axial) Load Factor	unitless
F_{aG}	Thrust Force on Gear	N, lbf	Z	Number of Rolling Elements	unitless
F_{ai}	Induced Thrust (Axial) Load Due to Radial Loading	N, lbf	α	Ball Bearing Nominal Contact Angle	deg.
			δ_H	Interference Fit of Outer Ring in Housing	mm, in.
			δ_S	Interference Fit of Inner Ring on Shaft	mm, in.
			ΔT	Temperature Difference Between Shaft/Inner Ring/Rollers and Housing/Outer Ring	°C, °F
			ϕ_G	Normal Tooth Pressure Angle for the Gear	deg.
			ϕ_P	Normal Tooth Pressure Angle for the Pinion	deg.
			Ψ_G	Helix (Helical) or Spiral Angle for the Gear	deg.
			Ψ_P	Helix (Helical) or Spiral Angle for the Pinion	deg.

FATIGUE LIFE

Bearing selection involves analyzing several different performance criteria including bearing fatigue life, rotational precision, power requirements, temperature limits and speed capabilities. This section focuses on bearing life as it relates to material-associated fatigue. Here we define bearing life as the length of time, or number of revolutions, until a fatigue spall of 6 mm² develops. Due to the large size of rolling mill bearings, bearings commonly operate beyond this limit and greater life can be expected.

Because metal fatigue is a statistical phenomenon, bearings that may appear to be identical can exhibit considerable differences in life when tested under identical conditions. Therefore, it is necessary to base life predictions on a statistical evaluation of a large number of bearings operating under similar conditions. The Weibull distribution function is commonly used to predict the life of a population of bearings at any given reliability level. For rolling mill bearings, where it is impractical to test a large number of bearings, Timken engineers can help you in your bearing life calculation.⁽¹⁾

A bearing's recorded life depends on factors such as load, speed, lubrication, fitting, internal bearing clearance, operating temperature, contamination, maintenance and many other environmental factors. It is important to note that, statistically, the life of a system with multiple rows will always be less than the life of any given row in the system.

Rated life (L_{10}), as shown in fig. 114, is the life that 90 percent of a group of apparently identical bearings will complete or exceed before a fatigue spall reaches a defined limit. L_{10} is associated with 90 percent reliability for a single bearing under a certain load. The median life, or L_{50} , is approximately 3.5 times the L_{10} life.

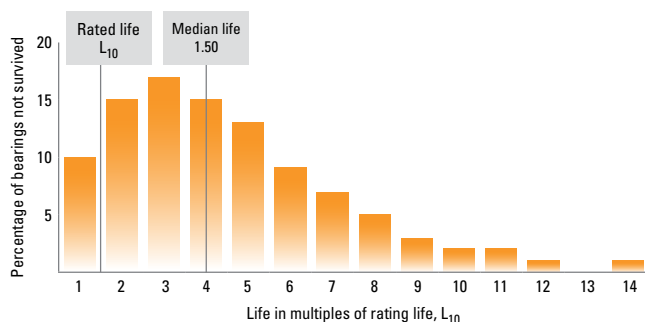

Fig. 114. Theoretical life frequency distribution of one hundred apparently identical bearings operating under similar conditions.

BEARING RATINGS

Bearing manufacturers assign load ratings to bearings that permit designers to calculate bearing life expectancy. Two standard reference ratings are widely used. C_{90} is the reference load rating for 90 million revolutions and C_1 is a standard reference for one million revolutions. The C_{90} rating is predominantly used for tapered roller bearing life calculations, while C_1 is more commonly used for spherical and cylindrical roller bearings. Since bearings operate at loads other than either of the standard references, it is important that the proper life equation is used with the respective rating.

⁽¹⁾ NOTE

The life of an individual bearing cannot be precisely defined.

TIMKEN DYNAMIC RATINGS C_{90}

Timken developed and validated a specific rating method for roller bearings, taking into account continuous improvements in material cleanliness and manufacturing technology.

RADIAL LOAD RATINGS

The published Timken C_{90} ratings are established on a basic rated life of 90 million revolutions, or 3000 hours at 500 rev/min. To ensure consistent quality worldwide, Timken conducts extensive bearing fatigue life tests in our laboratories. These audit tests result in a high level of confidence in our ratings.

To estimate the life of a rotating bearing, we use basic dynamic load rating, which is formulated as:

$$C_{90} = M_c H (i L_{\text{eff}} \cos \alpha)^{4/5} Z^{7/10} D_{\text{we}}^{16/15}$$

where (fig. 115):

- C_{90} = Radial rating (est.)
- M_c = Material constant
- H = Geometry-dependent factor
- i = Number of rows within an assembly
- L_{eff} = Roller effective length (in.)⁽¹⁾
- α = Bearing half included outer-race angle in degrees
- Z = Number of rollers per row
- D_{we} = Mean roller diameter (in.)

⁽¹⁾ Roller effective length is the roller-raceway length able to take the load. It is a function of roller body length L and the geometry of the roller radii and the corresponding raceway.

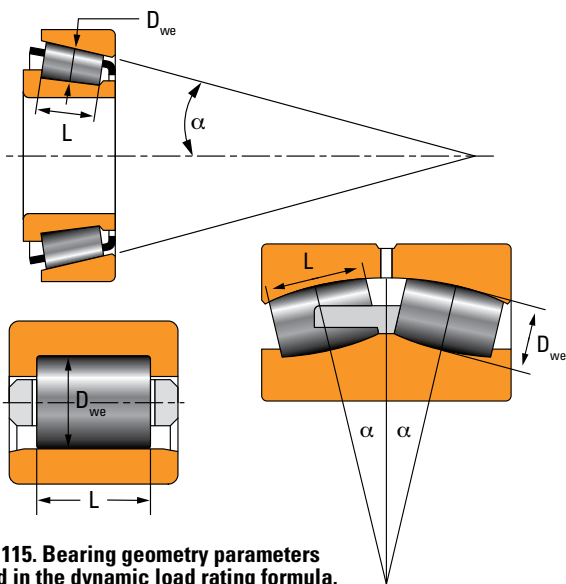

Fig. 115. Bearing geometry parameters used in the dynamic load rating formula.

The system life of both rows determines the rating for double-row bearings in which both raceways have the same geometry.

$$C_{90(2)} = 2^{4/5} \times C_{90} \quad \text{or} \quad C_{90(2)} = 1.74 \times C_{90}$$

Two times the double-row rating is the basic radial load rating of a four-row assembly.

$$C_{90(4)} = 2 \times C_{90(2)}$$

Three times the double-row rating is the basic radial load rating of a six-row assembly.

$$C_{90(6)} = 3 \times C_{90(2)}$$

TIMKEN DYNAMIC RATING C_1

Our Timken rating for one million revolutions is:

$$C_1 = C_{90} \times 90^{3/10} = C_{90} \times 3.857$$

The Timken C_1 rating enables you to make a direct comparison between Timken bearings and other manufacturers using ratings evaluated on a basis of one million revolutions. However, a direct comparison between ratings of various manufacturers may be misleading due to differences in rating philosophy, material, manufacturing, design and validation testing.

In order to make a true geometrical comparison between the ratings of different bearing suppliers, only use the rating published by the International Standards Organization (ISO) equation. However, by doing this, it does not account for differences in steel qualities from one bearing manufacturer to another.

DYNAMIC AXIAL LOAD RATING FOR RADIAL ROLLER BEARINGS

The specific bearing type determines the axial load-carrying capability of radial roller bearings. In tapered roller bearings, where the design is particularly suited for combined loading, the race angle of the bearing's outer ring primarily determines the axial load rating. For every tapered roller bearing, Timken publishes a K-factor, which is the ratio of the dynamic radial-load rating to the thrust-load rating of a single-row bearing:

$$K = \frac{C_{90}}{C_{a90}}$$

where:

C_{90} is the basic dynamic radial load rating and C_{a90} is the basic dynamic thrust load rating, based on a rating life of 90 million revolutions (3000 hours at 500 rev/min.).

The smaller the K-factor, the steeper the bearing cup angle and the greater the axial load-carrying capability of the bearing (fig. 116).

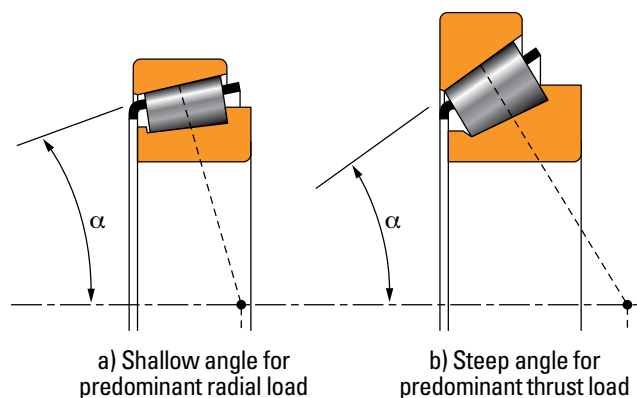

Fig. 116. Shallow-angle versus steep-angle configuration.

The relationship also is geometrically expressed as:

$$K = 0.389 \times \cot \alpha$$

where:

$$\alpha = \text{Half included outer-race angle}$$

We design spherical bearings for either pure radial or radial-and axial-combined loading. The axial load limit is not published because spherical bearings are not intended for pure axial loading.

Axial load-carrying capacity of cylindrical bearings is principally determined by the ability of the flanges on the inner and outer rings to support a load, as well as by the thermal conditions at the roller/flange contact area. The sliding contact between the roller end and flange, which is influenced by bearing operating temperature, lubrication, misalignment and loads, regulates thermal conditions. Under normal operating conditions, the axial load should not exceed 10 percent of the applied radial load.

STATIC LOAD RATING C_0

Standard bearing fatigue life is calculated in terms of bearing revolutions. However, for static applications, the concept of fatigue life is not appropriate. In this case, we determine bearing selection by the maximum permissible load we can apply. We define this as the load that we can apply without altering the physical properties in a way that degrades bearing performance. For static conditions, the maximum contact stress at the bearing raceway must be less than 4000 MPa (580 ksi), which is considered to be the Brinnell limit for bearing steel. Stress levels above this value may plastically deform the contact surfaces and create initiation sites for future spalling, even under lighter loads.

C_0 is the basic static load rating for Timken bearings. We base this on a maximum contact stress of 4000 MPa (580 ksi) at the center of contact on the most heavily loaded rolling element.

If sound, vibration or torque is critical, or if a pronounced shock load is present, apply a lower load limit.

For more in-depth knowledge on these ratings, please contact your Timken engineer.

APPLIED LOADS

The traditional approach to bearing life calculation begins with the determination of applied forces and calculation of a bearing's dynamic equivalent load. From there, the expected catalog life is calculated for single- or multiple-row bearings.

In rolling-mill applications, the determination of the applied forces depends on the mill configuration and a wide range of conditions given by the rolling-mill schedules. It would, therefore, not be adequate to develop a standard calculation based only on the maximum load and/or speed. Only through a close partnership with your engineering department and a per-project basis can you make a realistic estimation of bearing life. Experience with similar applications provides a good starting point for initial evaluation.

Common bearing applications within rolling mills include mill drives, pinion stands, backup, intermediate and work-roll positions, screwdown systems and auxiliary equipment. To determine applied forces developed by machine elements in the applications, we use the following equations:

Additional gearing types can be found in the Timken Engineering Manual (order no. 10424).

GEARING

SPUR GEARING

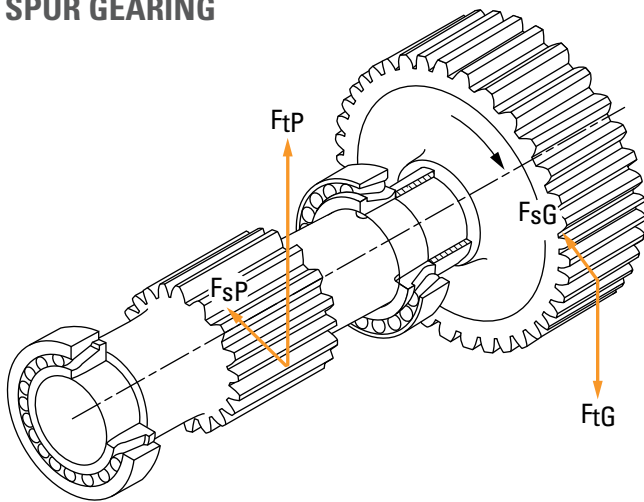

Fig. 117. Spur gearing.

Tangential force

$$F_{tG} = \frac{(1.91 \times 10^7) H}{D_{pG} n_G} \text{ (metric system)}$$

$$= \frac{(1.26 \times 10^5) H}{D_{pG} n_G} \text{ (inch system)}$$

Separating force

$$F_{sG} = F_{tG} \tan \phi_G$$

SINGLE-HELICAL GEARING

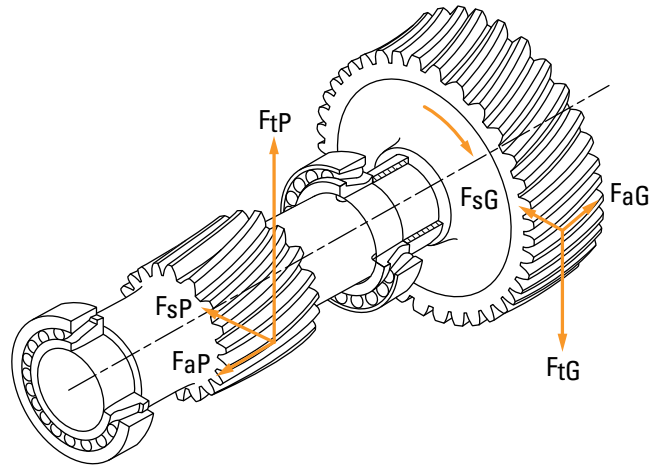

Fig. 118. Single-helical gearing.

Tangential force

$$F_{tG} = \frac{(1.91 \times 10^7) H}{D_{pG} n_G} \text{ (metric system)}$$

$$= \frac{(1.26 \times 10^5) H}{D_{pG} n_G} \text{ (inch system)}$$

Separating force

$$F_{sG} = \frac{F_{tG} \tan \phi_G}{\cos \psi_G}$$

Thrust force

$$F_{aG} = F_{tG} \tan \psi_G$$

STRAIGHT BEVEL AND ZEROL GEARING WITH ZEROL DEGREES SPIRAL

In straight bevel and zerol gearing, the gear forces tend to push the pinion and gear out of mesh, such that the directions of the thrust and separating forces are always the same, regardless of direction of rotation (fig. 119). In calculating the tangential force (F_{tP} or F_{tG}) for bevel gearing, use the pinion or gear mean diameter (D_{mP} or D_{mG}) instead of the pitch diameter (D_{pP} or D_{pG}). Calculate the mean diameter as follows:

$$D_{mG} = D_{pG} - b \sin \gamma_G$$

$$D_{mP} = D_{pP} - b \sin \gamma_P$$

In straight bevel and zerol gearing:

$$F_{tP} = F_{tG}$$

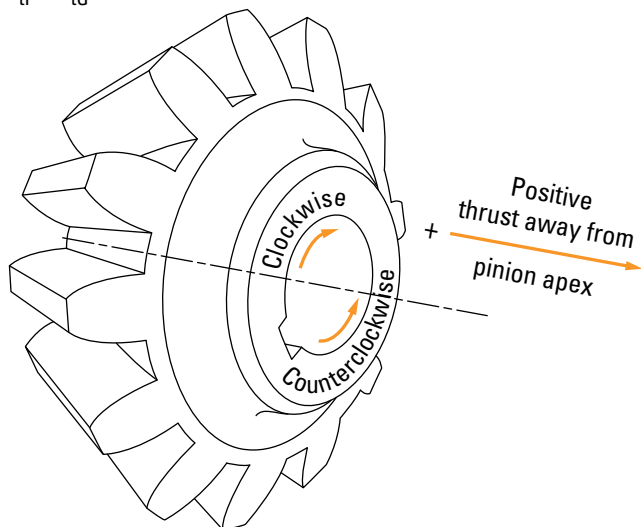

Fig. 119. Straight bevel and zerol gears – thrust and separating forces are always in same direction regardless of direction of rotation.

Pinion

Tangential force

$$F_{tP} = \frac{(1.91 \times 10^7) H}{D_{mP} n_p} \text{ (metric system)}$$

$$\frac{(1.26 \times 10^5) H}{D_{mP} n_p} \text{ (inch system)}$$

Thrust force

$$F_{aP} = F_{tP} \tan \phi_P \sin \gamma_P$$

Separating force

$$F_{sP} = F_{tP} \tan \phi_P \cos \gamma_P$$

Straight Bevel Gear

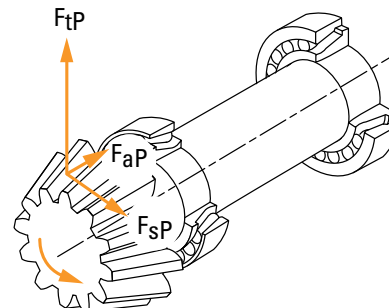
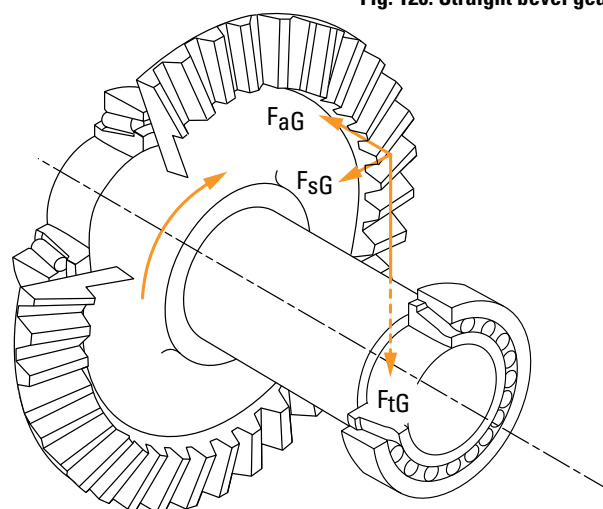

Fig. 120. Straight bevel gearing.



Tangential force

$$F_{tP} = \frac{(1.91 \times 10^7) H}{D_{mP} n_p} \text{ (metric system)}$$

$$= \frac{(1.26 \times 10^5) H}{D_{mP} n_p} \text{ (inch system)}$$

Thrust force

$$F_{aG} = F_{tG} \tan \phi_G \sin \gamma_G$$

Separating force

$$F_{sG} = F_{tG} \tan \phi_G \cos \gamma_G$$

SPIRAL BEVEL AND HYPOID GEARING

In spiral bevel and hypoid gearing, the direction of the thrust and separating forces depends upon the spiral angle, hand of spiral, direction of rotation and whether the gear is driving or driven (see table 1 on next page). To determine the hand of the spiral, note whether the tooth curvature on the near face of the gear (fig. 121) inclines to the left or right from the shaft axis. Viewing toward the gear or pinion apex will determine direction of rotation.

In spiral bevel gearing:

$$F_{tP} = F_{tG}$$

In hypoid gearing:

$$F_{tP} = \frac{F_{tG} \cos \psi_P}{\cos \psi_G}$$

Hypoid pinion effective working diameter:

$$D_{mP} = D_{mG} \left(\frac{N_P}{N_G} \right) \left(\frac{\cos \psi_G}{\cos \psi_P} \right)$$

Tangential force

$$F_{tG} = \frac{(1.91 \times 10^7) H}{D_{mG} n_G} \text{ (metric system)}$$

$$= \frac{(1.26 \times 10^5) H}{D_{mG} n_G} \text{ (inch system)}$$

Hypoid gear effective working diameter:

$$D_{mG} = D_{pG} - b \sin \gamma_G$$

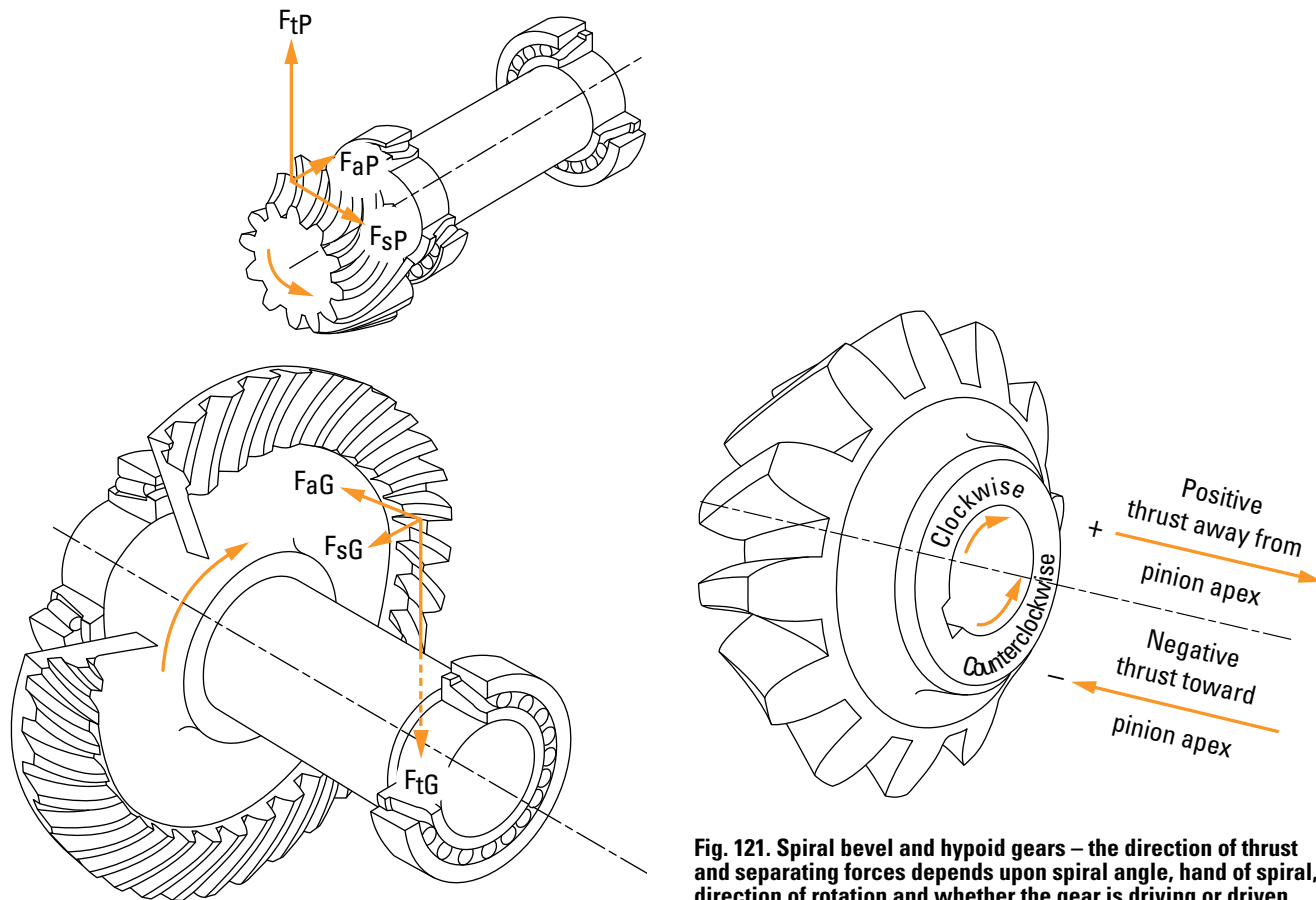

Fig. 121. Spiral bevel and hypoid gears – the direction of thrust and separating forces depends upon spiral angle, hand of spiral, direction of rotation and whether the gear is driving or driven.

TABLE 1. SPIRAL BEVEL AND HYPOID GEARING EQUATIONS

Driving Member Rotation	Thrust Force	Separating Force
Right-hand spiral clockwise or Left-hand spiral counterclockwise	Driving Member $F_{aP} = \frac{F_{tP}}{\cos \psi_P} (\tan \phi_P \sin \gamma_P - \sin \psi_P \cos \gamma_P)$	Driving Member $F_{sP} = \frac{F_{tP}}{\cos \psi_P} (\tan \phi_P \cos \gamma_P + \sin \psi_P \sin \gamma_P)$
	Driven Member $F_{aG} = \frac{F_{tG}}{\cos \psi_G} (\tan \phi_G \sin \gamma_G + \sin \psi_G \cos \gamma_G)$	Driven Member $F_{sG} = \frac{F_{tG}}{\cos \psi_G} (\tan \phi_G \cos \gamma_G - \sin \psi_G \sin \gamma_G)$
Right-hand spiral counterclockwise or Left-hand spiral clockwise	Driving Member $F_{aP} = \frac{F_{tP}}{\cos \psi_P} (\tan \phi_P \sin \gamma_P + \sin \psi_P \cos \gamma_P)$	Driving Member $F_{sP} = \frac{F_{tP}}{\cos \psi_P} (\tan \phi_P \cos \gamma_P - \sin \psi_P \sin \gamma_P)$
	Driven Member $F_{aG} = \frac{F_{tG}}{\cos \psi_G} (\tan \phi_G \sin \gamma_G - \sin \psi_G \cos \gamma_G)$	Driven Member $F_{sG} = \frac{F_{tG}}{\cos \psi_G} (\tan \phi_G \cos \gamma_G + \sin \psi_G \sin \gamma_G)$

NOTE

Please refer to page 68 for a summary of symbols used in the equations.

ROLLING LOAD PATHS

BACKUP AND WORK-ROLL POSITIONS

For a conventional 4-Hi mill stand, the roll stand and rolled material transmits the basic loads on the bearings as shown in fig. 122. These bending forces may add or subtract from the larger roll-separating force used for strip thickness reduction, depending on the location of the roll balance and/or bending cylinders.

Generally, backup roll bearings take the rolling load, commonly referred to as separating force, plus all the other loads generated in the system. The work-roll and intermediate-roll bearings take the balancing load and bending forces if they exist. Depending on the mill design, there will be some parasitic axial loads created from misalignment, roll geometry, etc., which can represent 0.5 percent to two percent of the total rolling load. In some new mills, backup and work-roll bearings also take the axial loads induced by the roll crossing and/or by the axial shift systems that require a separate thrust bearing position.

When the applied loads on the bearings are known and have a defined duty cycle, the more accurate the predicted bearing life calculation will be with the actual bearing performance.

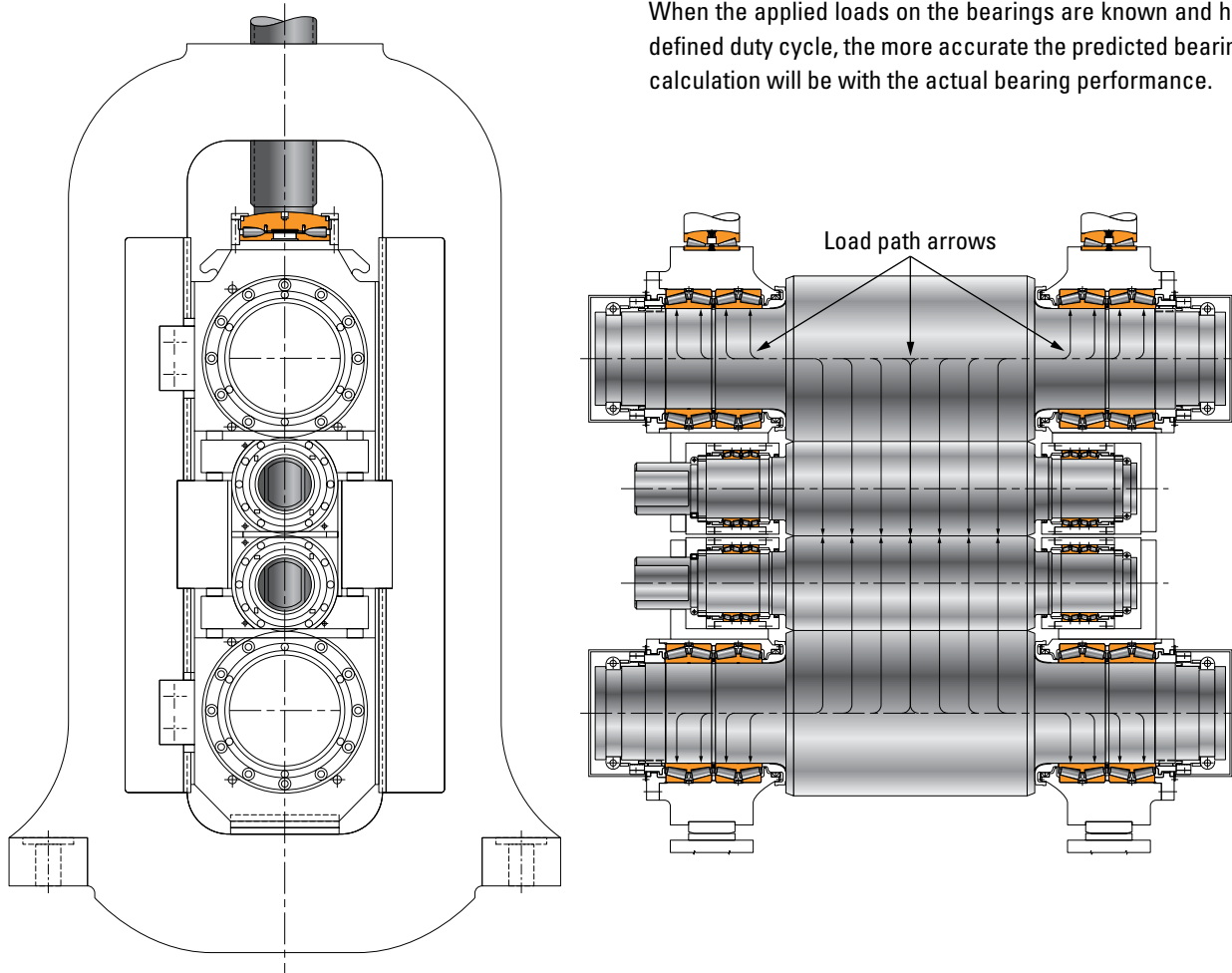

Fig. 122. Typical 4-Hi mill with roll load path.

EQUIVALENT DYNAMIC RADIAL LOADS (P_r)

The dynamic equivalent radial load (P_r) is defined as a single radial load that, if applied to the bearing, results in the same life as the combined radial and axial loading under which the bearing operates. This general expression represents the dynamic equivalent load:

$$P_r = XF_r + YF_a$$

where:

P_r = Dynamic equivalent radial load

X = Radial load factor

F_r = Applied radial load

Y = Axial load factor

F_a = Applied axial load

The values of X and Y , which vary by bearing type, are discussed in further detail below.

CYLINDRICAL ROLLER BEARINGS

Cylindrical roller bearings can be configured to accommodate a small axial load. However, for heavy-duty applications in the metals industry, it is practical to add a second bearing to specifically take any thrust loading. In this case, the cylindrical roller bearing will support radial loading only and the dynamic equivalent radial load is equal to the net radial load.

$$P_r = F_r$$

SPHERICAL ROLLER BEARINGS

The dynamic equivalent load is determined using the following equations. First calculate the ratio of axial to radial load, then compare this ratio to the e value for the bearing.

$$P_r = F_r + YF_a \quad \text{for} \quad \frac{F_a}{F_r} \leq e$$

$$P_r = 0.67F_r + YF_a \quad \text{for} \quad \frac{F_a}{F_r} > e$$

Values for e and Y are available in product tables, by part number.

TAPERED ROLLER BEARINGS

Tapered roller bearings are ideally suited to carry all types of loads including pure radial, pure axial or a combination of both loads. Due to the tapered design, a radial load induces an axial reaction within the bearing that must be equally opposed to avoid separation of the inner and outer rings. When a single-row bearing is used, it must be paired against another single-row bearing. For multiple-row bearing configurations, an induced axial force will act in the load zone, requiring correctly sized end caps and screws to withstand it and maintain clamping function.

Single-row mountings

The equations for determining thrust reactions and dynamic equivalent radial load in a system of two single-row bearings are based on the following assumptions:

- Load zone of 180 degrees in one bearing (the set-up bearing) and,
- Load zone of 180 degrees or more in the opposite bearing (seated bearing).

Load zone is the angular representation of the number of rollers in the bearing⁽¹⁾. Catalog analysis makes these simplifying assumptions about load zone, however, in a more advanced analysis, the actual load zone (a function of both radial and axial-bearing reactions) within the bearing is used to correlate the bearing reaction to the dynamic equivalent radial load. This sophisticated analysis requires numerical and analytical tools developed by Timken and other leading bearing manufacturers.

⁽¹⁾ See page 84, load zone life factor (a_{3k}).

BEARING LIFE CALCULATIONS AND RELATED ANALYSIS

APPLIED LOADS

For single-row bearings, the following table can be used to calculate the dynamic radial equivalent load. First, determine if bearings are mounted in a direct or indirect arrangement and to which bearing the thrust load (F_{ae}) is applied. Once the appropriate bearing arrangement is established, check the table to determine which thrust load and dynamic equivalent radial load equations apply.

TABLE 2. COMBINED RADIAL AND THRUST LOAD (SINGLE-ROW)

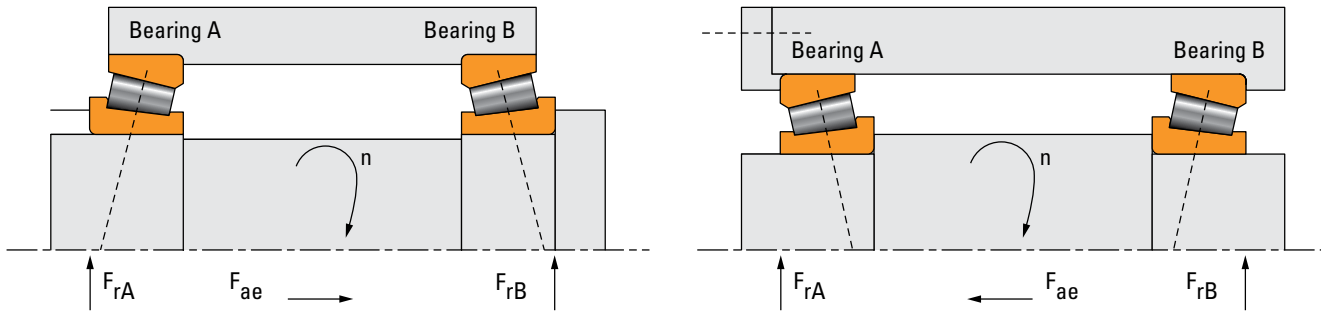

ISO Method		Timken Method	
Thrust Condition			
$\frac{0.5 F_{rA}}{Y_A} \leq \frac{0.5 F_{rB} + F_{ae}}{Y_B}$	$\frac{0.5 F_{rA}}{Y_A} > \frac{0.5 F_{rB} + F_{ae}}{Y_B}$	$\frac{0.47 F_{rA}}{K_A} \leq \frac{0.47 F_{rB} + F_{ae}}{K_B}$	$\frac{0.47 F_{rA}}{K_A} > \frac{0.47 F_{rB} + F_{ae}}{K_B}$
Axial Load			
$F_{aA} = \frac{0.5 F_{rB}}{Y_B} + F_{ae}$ $F_{aB} = \frac{0.5 F_{rB}}{Y_B}$	$F_{aA} = \frac{0.5 F_{rA}}{Y_A}$ $F_{aB} = \frac{0.5 F_{rA}}{Y_A} - F_{ae}$	$F_{aA} = \frac{0.47 F_{rB}}{K_B} + F_{ae}$ $F_{aB} = \frac{0.47 F_{rB}}{K_B}$	$F_{aA} = \frac{0.47 F_{rA}}{K_A}$ $F_{aB} = \frac{0.47 F_{rA}}{K_A} - F_{ae}$
Dynamic Equivalent Radial Load			
Bearing A			
$P_A = F_{rA}$, if $\frac{F_{aA}}{F_{rA}} \leq e_A$ or $P_A = 0.4 F_{rA} + Y_A F_{aA}$, if $\frac{F_{aA}}{F_{rA}} > e_A$	$P_A = F_{rA}$	$P_A = 0.4 F_{rA} + K_A F_{aA}^{(1)}$	$P_A = F_{rA}$
Bearing B			
$P_B = F_{rB}$	$P_B = F_{rB}$, if $\frac{F_{aB}}{F_{rB}} \leq e_B$ or $P_B = 0.4 F_{rB} + Y_B F_{aB}$, if $\frac{F_{aB}}{F_{rB}} > e_B$	$P_B = F_{rB}$	$P_B = 0.4 F_{rB} + K_B F_{aB}^{(1)}$
ISO 281 Factors $e = 1.5 \tan \boxtimes = 0.59 K$ $Y = 0.4 \cot \boxtimes = 1.03 K$		where: $\boxtimes =$ Half included cup angle $K = 0.389x \cot \boxtimes$	
		(1) If $P_A < F_{rA}$, use $P_A = F_{rA}$ and if $P_B < F_{rB}$, use $P_B = F_{rB}$	

Double-row bearings

For double-row tapered roller bearings, or for single-row bearing pairs, table 3 is used. In this table, only bearing A has an applied thrust load. If the external thrust load is applied to bearing B, the A's in the equations should be replaced by B's and vice versa.

TABLE 3. COMBINED RADIAL AND THRUST LOAD (DOUBLE-ROW)

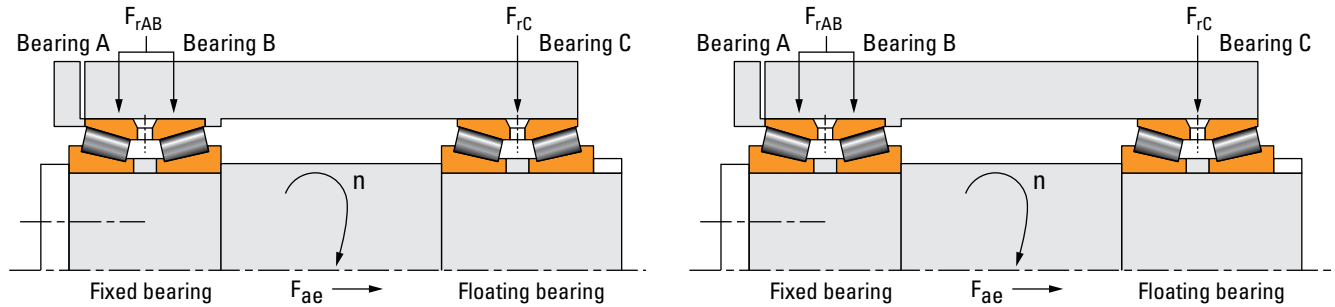

ISO Method		Timken Method	
Thrust Condition			
$\frac{F_{ae}}{F_{rAB}} \leq e$	$\frac{F_{ae}}{F_{rAB}} > e$	$F_{ae} > \frac{0.6 F_{rAB}}{K_A}$	$F_{ae} \leq \frac{0.6 F_{rAB}}{K_A}$
Dynamic Equivalent Radial Load			
$P_{AB} = F_{rAB} + Y_{1AB} F_{ae}$ $P_C = F_{rC}$	$P_{AB} = 0.67 F_{rAB} + Y_{2AB} F_{ae}$ $P_C = F_{rC}$	$P_{AB} = 0.4 F_{rAB} + K_A F_{ae}$ $F_B = 0$ $P_C = F_{rC}$	$P_A = 0.5 F_{rAB} + 0.83 K_A F_{ae}$ $P_B = 0.5 F_{rAB} - 0.83 K_A F_{ae}$ $P_C = F_{rC}$

ISO 281 Factors

$$e = 1.5 \tan \alpha = 0.59 K$$

$$Y_1 = 0.45 \cot \alpha = 1.15 K$$

$$Y_2 = 0.67 \cot \alpha = 1.72 K$$

Four- and six-row bearings

Pure radial load

In the case where axial loading is excessive, an additional thrust bearing is used to take the axial load. The four-row bearing is only carrying radial loads. For pure radial loads, the bearing life calculation is done by making the dynamic equivalent radial load (P_r) equal to the radial load and by using the dynamic radial rating for four rows, which defines the system life of the bearing assembly. Six-row bearings are available for special applications, consult your Timken engineer for life calculations.

Combined radial and axial loads

When no additional thrust bearing is used, the life of the four- or six-row bearing is considered to be almost equal to the life of the heaviest loaded pair of rows. Once the load on the heaviest loaded pair of rows is determined, bearing life is calculated using the life calculation for a two-row bearing.

Four-row bearing

Due to precision manufacturing and assembly tolerances, it is assumed, for calculation purposes, that for a four-row bearing the radial load is equally shared between each pair of rows and that the axial load is shared 40 percent on one pair and 60 percent on the other pair. In this case, the heaviest loaded pair takes 50 percent of the radial load and 60 percent of the axial load (fig. 123).

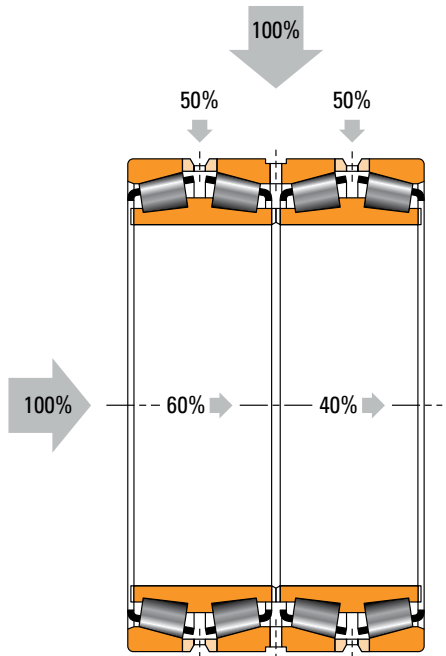

Fig. 123. Combined load sharing in a four-row tapered roller bearing for basic life calculations.

Six-row bearing

A six-row bearing may be appropriate in conditions where the strip width is very large or roll shifting is used to control the strip profile.

The radial load is equally shared on each pair of rows and one of the three pairs takes 40 percent of the thrust load and the two others 30 percent each. The heaviest loaded pair then takes 33 percent of the radial load and 40 percent of the axial load (fig. 124).

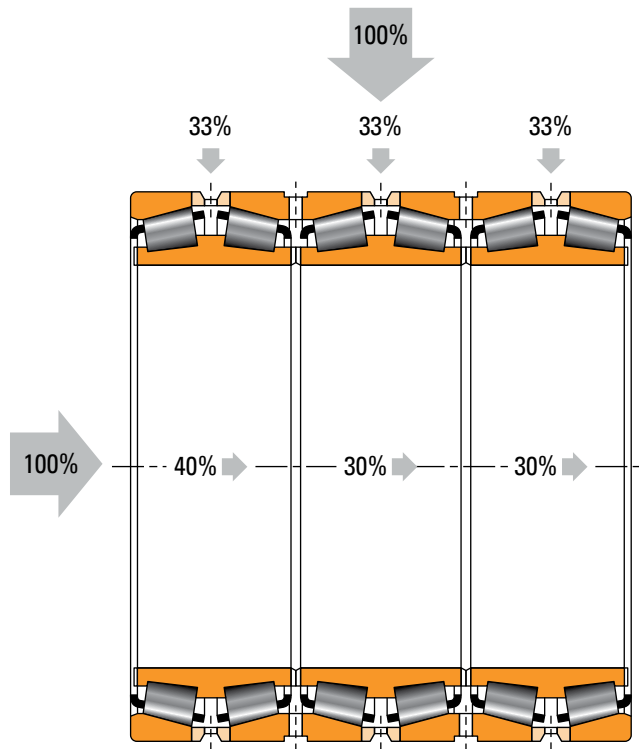

Fig. 124. Combined load sharing in a six-row tapered roller bearing for basic life calculations.

EQUIVALENT THRUST DYNAMIC LOADS (P_a)

CYLINDRICAL AND TAPERED THRUST BEARINGS

Cylindrical and tapered thrust bearings should be mounted in a way that only thrust loads apply. Avoid radial loading by providing appropriate clearances between the bearing rings and the non-piloted surfaces. If the radial load is zero, P_a will be equal to the applied thrust load (F_a). If any radial load is expected in the application, consult your Timken engineer for advice on bearing selection.

SPHERICAL THRUST ROLLER BEARINGS

For spherical thrust roller bearings, thrust dynamic loads are determined by:

$$P_a = 1.2 F_r + F_a$$

While spherical thrust bearings are designed for radial and axial combined loading, the applied load should be predominantly axial with $F_r \leq 0.55 F_a$. Because of the steep roller angle and the fact that the bearing is separable, a radial load will induce a thrust component ($F_{ai} = 1.2F_r$) that must be resisted by another thrust bearing, an axial load greater than F_{ai} , or spring loading.

SLOW-ROTATING EQUIPMENT

In some applications, such as continuous casters, rotational speed can be as slow as 1 rev/min. Low rotational speeds mean that a hydrodynamic lubricant film cannot develop between the rollers and raceways, therefore, the bearing is not working in a true dynamic regime, and a static analysis is more appropriate. Generally, bearing selection can be based on a 3:1 ratio of the bearing static capacity (C_o) to the applied equivalent radial load (P_r). In cases where application loads are very high, the contact stress profile between the rollers and the races must be considered. If the maximum stress is higher than 2750 MPa (400 ksi), then a special modified roller profile should be considered to balance the stress along the roller-race contact line (fig. 125).

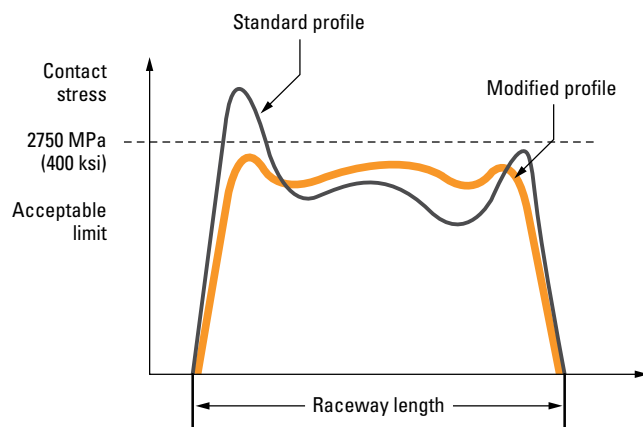

Fig. 125. Stress distribution along the race width.

BEARING LIFE EQUATIONS

CATALOG BEARING LIFE EQUATIONS

Typically, bearing life based on one million cycles (L_{10}) is calculated as follows for roller bearings under radial or combined loading where the dynamic equivalent radial load has been determined:

$$L_{10} = \left(\frac{C_r}{P_r} \right)^{10/3} \left(\frac{1 \times 10^6}{60n} \right) \text{ hours}$$

Where:

n = Rotational speed in rev/min.

For thrust bearings, the catalog life equations are:

$$L_{10} = \left(\frac{C_a}{P_a} \right)^{10/3} \left(\frac{1 \times 10^6}{60n} \right) \text{ hours}$$

Tapered roller bearings often use a dynamic load rating based on 90 million cycles, as opposed to one million cycles, changing the equations as follows:

$$L_{10} = \left(\frac{C_{90}}{P_r} \right)^{10/3} \left(\frac{500}{n} \right) \times 3000 \text{ hours}$$

and

$$L_{10} = \left(\frac{C_{a90}}{P_a} \right)^{10/3} \left(\frac{500}{n} \right) \times 3000 \text{ hours}$$

L_{10} is generally used throughout the industry in rolling mill calculations, especially for original equipment manufacturers' (OEM) bearing selections. L_{10} refers to catalog life calculations using only load and speed, where no environmental effect is considered. This is why L_{10} also is referred to as catalog life.

LIFE CALCULATION FOR A GIVEN LOAD CYCLE

Rolling mills work in more than one defined condition. Therefore, it is preferable to calculate the bearing life at different loads, speeds and durations, then summarize the results in a weighted bearing life L_{10wt} . After the duty cycle is defined (loads, speeds and percentage of time), the weighted L_{10} life is obtained as shown below.

$$L_{10wt} = \frac{100}{\left(\frac{T_1}{L_{10(1)}} + \frac{T_2}{L_{10(2)}} + \dots + \frac{T_n}{L_{10(n_n)}} \right)}$$

where:

- n_n = Number of load conditions
- T = Percent time for each condition
- L_{10} = L_{10} life for each condition (hours)
- L_{10wt} = Weighted bearing life (hours)

ADJUSTED BEARING LIFE EQUATIONS

With increased emphasis on the relationship between the reference conditions and the actual environment in which the bearing operates, the traditional life equations have been expanded to include further variables that affect bearing performance.

The ISO/ABMA expanded bearing life equation is:

$$L_{10a} = a_1 a_2 a_3 L_{10}$$

where:

- a_1 = Reliability life factor
- a_2 = Material life factor
- a_3 = Operating condition life factor (to be specified by the manufacturer)

The Timken expanded bearing life equation is:

$$L_{10a} = a_1 a_2 a_{3d} a_{3k} a_{3l} a_{3m} a_{3p} L_{10}$$

where:

- a_1 = Reliability life factor
- a_2 = Material life factor
- a_{3d} = Debris life factor
- a_{3k} = Load-zone life factor
- a_{3l} = Lubrication life factor
- a_{3m} = Misalignment life factor
- a_{3p} = Low-load life factor. For rolling-mill applications, this factor is taken as 1.

The L_{10a} expanded life refers to the bearing life where adjustment factors are considered for bearing analysis and selection. Bearing system analysis and adjusted life calculations are seldom done by hand since the analysis is very complex. Bearing system analysis is part of the Timken® Syber Bearing System Analysis program that is used to model rolling-mill applications. Syber uses a finite element approach on shafts, bearings and housings based on data received from customers.

A typical analysis includes bearing, housing and shaft behaviors for given loads, speeds, specified lubricant type, operating temperature and other environmental factors. The program analyzes behaviors such as deflections and deformations, contact stresses, film thickness, torque, operating clearance and adjusted life, to name a few.

For more information on such detailed analysis, consult your Timken engineer.

To be noted that the accuracy of the Timken technical reviews is dependent upon the validity and completeness of information supplied to The Timken Corporation. Actual product performance is affected by many factors beyond the control of The Timken Corporation. Therefore, the suitability and feasibility of all designs and product selection should be validated by customers. For the above reasons, Timken application reviews are submitted solely to provide customers of The Timken Corporation or their parent or affiliates, with data to assist in their design. No warranty, expressed or implied, including any warranty of fitness for a particular purpose, is made by Timken by the submission of application reviews. Timken products are sold subject to the Limited Warranty which is set forth in Timken's terms and conditions of sale.

RELIABILITY LIFE FACTOR (a_1)

Reliability, in the context of bearing life for a group of apparently identical bearings operating under the same conditions, is the percentage of the group that is expected to attain or exceed a specified life. The reliability of an individual bearing is the probability that the bearing will attain or exceed a specified life.

The reliability life adjustment factor is:

$$a_1 = 4.26 \left(\ln \frac{100}{R} \right)^{2/3} + 0.05$$

ln = natural logarithm (base e)

To adjust the calculated L_{10} life for reliability, multiply by the a_1 factor. If 90 (90 percent reliability) is substituted for R in the above equation, $a_1 = 1$. For R = 99 (99 percent reliability), $a_1 = 0.25$. The following table 4 lists the reliability factor for commonly used reliability values.

TABLE 4. RELIABILITY FACTORS

R (percent)	L_n	a_1
90	L_{10}	1.00
95	L_5	0.64
96	L_4	0.55
97	L_3	0.47
98	L_2	0.37
99	L_1	0.25
99.5	$L_{0.5}$	0.175
99.9	$L_{0.1}$	0.093

Note that the equation for reliability adjustment assumes there is a short minimum life below which the probability of bearing damage is minimal (e.g., zero probability of bearing damage producing a short life). Extensive bearing fatigue life testing has shown the minimum life, below which the probability of bearing damage is negligible, to be larger than predicted using the above adjustment factor. For a more accurate prediction of bearing lives at high levels of reliability, consult your Timken engineer.

MATERIAL LIFE FACTOR (a_2)

The quality of the steel used in bearings is very important. Under repeated stress conditions, non-metallic inclusions initiate the spalling process and a fatigue spall can develop.

At Timken, we develop and manufacture our own steel. We have improved our steel quality over the years. Our life equation takes into account this material improvement by way of the steel-quality adjustment factor a_2 . For standard Timken bearings manufactured from bearing-quality steel, a conservative factor of 1 is used.

Due to the special demands on bearings used in metal processing, Timken offers bearings manufactured from maximum air-melt steels. Premium steels contain fewer and smaller inclusion impurities than standard steels and provide extended bearing fatigue life where it is limited by non-metallic inclusions.

For example, Timken® DuraSpexx® bearings, which feature enhanced materials, surface finishes and profiled geometries, often are used in rolling-mill applications. DuraSpexx bearings include air-melt steels that improve cleanliness by reducing the number of inclusions and modifying the shape of the inclusions. The published dynamic rating for selected DuraSpexx bearings with maximum air-melt steels is increased by 23 percent, extending fatigue life (similar to applying an a_2 factor of 2).

Application of the material life factor requires that fatigue life is limited by non-metallic inclusions, contact stresses are less than 2400 MPa (350 ksi) and that adequate lubrication is provided. It is important to note that improvements in material cannot offset poor lubrication or misalignment in a bearing's operating system. Consult your Timken engineer for applicability of the material factor.

LOAD-ZONE LIFE FACTOR (a_{3k})

The fatigue life of a bearing is, in part, a function of roller and raceway stresses and the number of stress cycles that the loaded bearing surfaces experience in one bearing revolution. Stresses depend on the applied load and on how many rollers support that load. In addition, the number of stress cycles depends on bearing geometry and the number of rollers supporting the load. Therefore, for a given external load, bearing life is related to the angular measurement of the number of rollers sharing the load, or load zone, of the bearing (fig. 126).

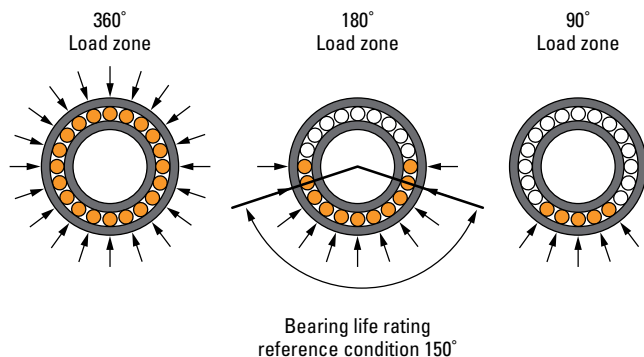

Fig. 126. Bearing load zone.

The size of the load zone in a bearing is determined by the internal clearance, either radial or axial, depending on the bearing type. It also depends on structural system stiffness, deflection and thermal gradients. A load zone of 150 degrees is assumed for initial bearing selection and a_{3k} equals 1.0. Reducing internal clearance would increase the number of rollers sharing the load, resulting in a larger load zone and subsequently longer bearing life provided that preload is not achieved.

The determination of this factor requires detailed knowledge of the bearing internal geometry. Contact your Timken engineer for more information.

LUBRICATION LIFE FACTOR (a_{3l})

Bearing life is directly linked to the lubricant film thickness. In turn, film thickness depends on lubricant viscosity, operating temperature, load, speed and surface finish of the bearing.

Extensive testing has been done by Timken to quantify the effects of lubrication-related parameters on bearing life. It is known that lubrication film is related to the amount of asperity (metal-metal) contact between the bearing surfaces and that improving roller and raceway surface finish has the most notable effect on improving lubricant film thickness and bearing performance. Additional factors, such as bearing geometry, material, load zone and speed also play important roles in film thickness and corresponding life.

The lubrication life adjustment factor will consider operating temperature, but does not take into account problems related to inadequate lubrication that can be caused by a number of circumstances, including:

- Contamination.
- Poor lubricant circulation.
- Incorrect oil-delivery system.
- Improper lubricant type or grade.
- Improper lubricant additives, grease or oil fill.
- Inadequate sealing.
- Presence of water.

The a_{3l} factor ranges from a maximum value of 2.88 to a minimum of 0.20 for case-carburized bearings and 0.13 for through-hardened bearings. The maximum lubricant-life adjustment value represents a high film thickness and minimal asperity contact. The minimum a_{3l} factor is a function of the material core condition because through-hardened bearings may produce lower bearing life in thin film conditions when compared with case-carburized bearings given equivalent surface finishes.

The determination of this factor requires detailed knowledge of the bearing internal geometry. Contact your Timken engineer for more information.

MISALIGNMENT LIFE FACTOR (a_{3m})

Misalignment between bearing rings is the relative angle between center-lines of the inner and outer rings as shown in fig. 127. The amount of permissible misalignment differs for the various bearing types and the effect of misalignment on bearing life depends on the magnitude of misalignment, internal bearing geometry and applied loads. The misalignment life factor (a_{3m}) calculates the effect on bearing life due to alignment, raceway contact truncation and raceway profiles.

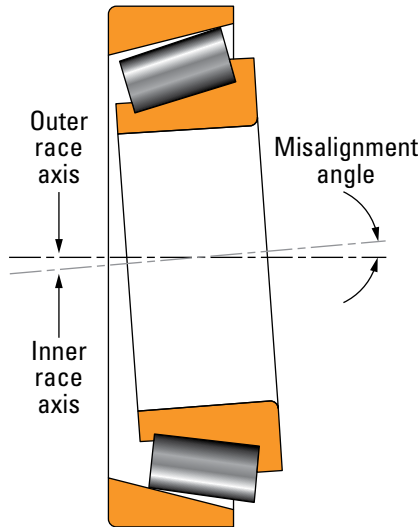

Fig. 127. Bearing misalignment.

The misalignment life factor for spherical bearings is equal to one, $a_{3m} = 1$, due to the self-aligning capabilities of a spherical roller bearing. The allowable misalignment in a spherical roller bearing is between ± 0.5 degrees and ± 1.25 degrees, depending upon the bearing series, as detailed in table 5. Bearing life will be reduced, due to roller-raceway contact truncation, if these misalignment limits are exceeded.

TABLE 5. MAXIMUM PERMISSIBLE MISALIGNMENT FOR SPHERICAL ROLLER BEARINGS BASED ON SERIES

Bearing series	Maximum misalignment
238	$\pm 0.5^\circ$
222, 230, 231, 239, 249	$\pm 0.75^\circ$
223, 240	$\pm 1.0^\circ$
232, 241	$\pm 1.25^\circ$

For tapered and cylindrical roller bearings, accurate alignment of the shaft relative to the housing is critical for best performance. The reference condition for the load rating is defined at 0.0005 radians (0.03 degrees) maximum misalignment, where $a_{3m} = 1$.

For applications where misalignment is present, the stress profile across the raceway is represented by fig. 128 and 129. In this case, a_{3m} will be less than one. Special profiles are applied to optimize the raceway stress distribution and improve a_{3m} . The misalignment life factor can exceed one if the actual conditions produce a better contact stress distribution than the reference condition.

Bearing performance under various levels of misalignment can be predicted using Timken Syber Bearing System Analysis. Consult your Timken engineer for more information.

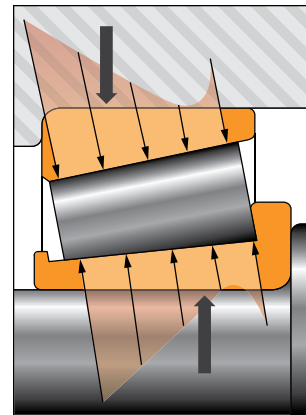

Fig. 128. Roller-raceway stress distribution with high misalignment and no special profile.

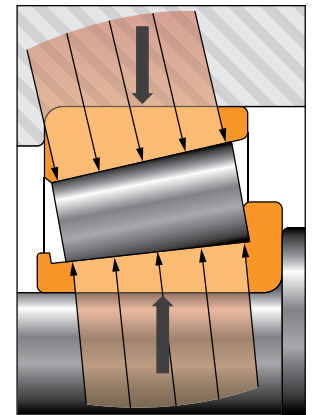

Fig. 129. Roller-raceway stress distribution with special profiling to minimize effect of misalignment.

BEARING INTERNAL CLEARANCE

The internal clearance in roller bearings greatly influences bearing performance including fatigue life, vibration, torque, heat-generation and ease of assembly. Consequently, the selection of the proper internal clearance is one of the most important tasks when choosing a bearing after the type and size are determined.

Bearing internal clearance is the combined clearance between the rings and the rolling elements. The radial and axial clearances are the total amount that one ring can be displaced relative to the other in the radial and axial directions respectively (fig. 130).

Correct bearing mounting and fitting practices are key components of proper bearing setting. The amount of clearance or interference within a mounted bearing is affected by the mounted fit of the inner and outer rings to the shaft and housing. Although mounted clearance is required for some bearings in the metals industry, each application position should be analyzed to determine the optimal setting. For this, dependent factors like load, speed, installation method, materials, runout accuracy, thermal conditions, hoop stress and shaft and housing design must be taken into consideration.

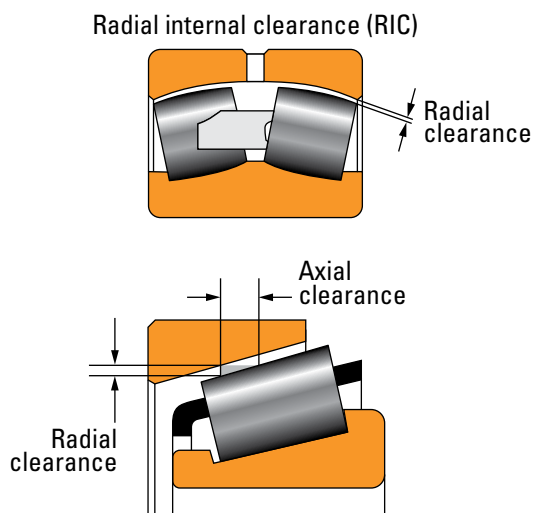

Fig. 130. Bearing internal clearance examples.

SPHERICAL AND CYLINDRICAL ROLLER BEARINGS

Radial internal clearance (RIC) is the radial play within a bearing. Timken bearing standard RIC (C0 or CN) for spherical and cylindrical bearings allows a standard tight fit with sufficient internal clearance remaining after installation for normal operating conditions.

For values of C0 and CN, see Timken Engineering Manual (order no. 10424).

Spherical and cylindrical roller bearings with tapered bore (K suffix) require a slightly greater interference fit on the shaft than would a cylindrical bore bearing. The effect of this greater interference fit is a larger reduction of RIC. For tapered bore bearings, it is critical to select a larger RIC to compensate for this requirement. This RIC reduction is reflected in the standard clearance tables, that differentiate between cylindrical and tapered-bore spherical and cylindrical roller bearings.

Several factors influence RIC reduction. As an example, inner rings pressed on to solid-steel shafts expand to approximately 80 percent of the interference fit. Outer rings pressed into steel or cast-iron housings reduce RIC by an amount dependent on the housing diameter and stiffness. To calculate the RIC reduction as a result of fitting practice, refer to page 88.

Timken spherical and cylindrical roller bearings are supplied with standard RIC unless otherwise specified.

TAPERED ROLLER BEARINGS

When only radial load is applied to a tapered roller bearing, for convenience in catalog life calculations, it is assumed that half the rollers support the load. The equations for determining bearing thrust reactions and equivalent radial loads in a system of two single-row bearings are based on the assumption of a 180-degree load zone in one of the bearings and 180 degrees or more in the opposite bearing.

The load zone, which has direct influence on bearing life, is directly linked to the bearing's internal clearance, called bearing setting. For tapered roller bearings, the clearance is determined in the axial direction. For single-row bearings, the setting must be established through measurements. Multi-row bearings (two rows or more) may have preset clearances referred to as either bench endplay (BEP) or bench preload (BPL), where the setting is achieved via spacers.

Operating setting is calculated by considering the initial bench setting, the mounting fits and the thermal expansion in the system because it is not possible to measure the setting under operating conditions.

$$\text{Operating Setting} = \text{BEP} - \text{Fitting Effect} \pm \text{Thermal Effect}$$

Although maximum life is obtained with the bearing operating in slight preload (fig. 131), this setting is generally avoided in rolling-mill applications where the operating conditions vary significantly. In these instances, the targeted operating setting is usually slight endplay, where the load zone is between 120 degrees to 160 degrees. Typical roll-neck bearing operating load zones range between 90 degrees and 110 degrees.

A computer analysis can be provided to show the influence of preload or endplay on bearing life.

For more details, refer to the Bearing Storage, Handling and Installation section.

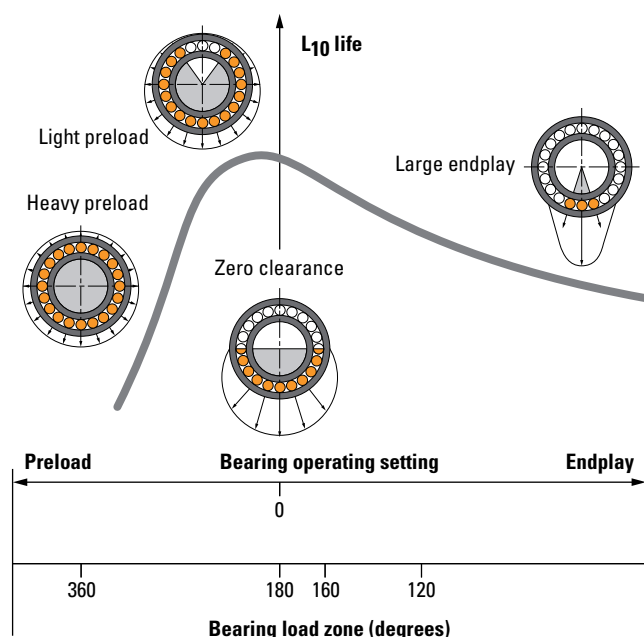

Fig. 131. Bearing life versus setting and load zone.

INFLUENCE OF FITTING ON THE SETTING

Bearing fitting practice has a direct influence on bearing internal clearance and effects bearing life and performance. Bearing fit is the amount of clearance or interference between a mounted bearing and the housing and shaft. A general rule consists of tight fitting the rotating members while stationary components are either tight- or loose-fitted as a function of the application design. An exception to this rule is the application of four-row or six-row, straight-bore tapered roller bearings on roll necks where loose fitted assemblies are used.

Generally, when bearings are mounted with interference on a shaft or in a housing, the rings either expand or contract, removing some internal clearance from the bearing. In the case where both inner and outer rings are loose-fitted, the internal clearance is not affected by mounting the bearing. Many factors such as load, temperature and mounting requirements must be considered when selecting the proper fit.

The effect of tight fits for spherical and cylindrical roller bearings is given as a reduction in the radial internal clearance. The fit effect for the tapered roller bearing is given as a reduction in the axial clearance or endplay.

The formulas on page 88 are used to calculate the effect of fitting practice for simple shaft and housing designs. For spherical and cylindrical roller bearings, the fit effect is determined in the radial direction, whereas for tapered roller bearings this is determined in the axial direction.

SPHERICAL ROLLER BEARINGS

Radial loss of internal clearance due to fit effects of inner race mounted on a solid or hollow shaft:

Solid Shaft:

$$\text{Fit Effect (inner ring)} = \cos \alpha \left(\frac{d}{d_o} \right) \delta_S$$

Hollow Shaft:

$$\text{Fit Effect (inner ring)} = \cos \alpha \left(\frac{d}{d_o} \right) \left\{ \frac{1 - \left(\frac{d_s}{d} \right)^2}{1 - \left(\frac{d_s}{d_o} \right)^2} \right\} \delta_S$$

Radial loss of internal clearance due to fit effects of outer-race mounted in a thin wall section housing:

$$\text{Fit Effect (outer ring)} = \cos \alpha \left(\frac{D_o}{D} \right) \left\{ \frac{1 - \left(\frac{D}{D_H} \right)^2}{1 - \left(\frac{D_o}{D_H} \right)^2} \right\} \delta_H$$

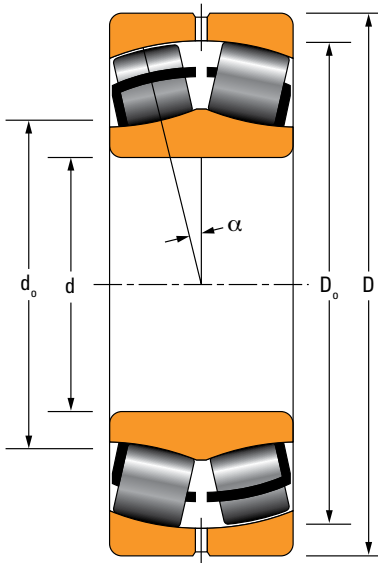

Fig. 132. Spherical roller bearing nomenclature.

- δ_S = Interference fit of inner race on shaft
- δ_H = Interference fit of outer race in housing
- d = Bearing bore diameter
- d_o = Mean inner-race diameter
- D = Bearing outside diameter
- D_o = Mean outer-race diameter
- d_S = Shaft inside diameter
- D_H = Housing outside diameter
- α = Contact angle

CYLINDRICAL ROLLER BEARINGS

Radial loss of internal clearance due to fit effects of inner race mounted on a solid or hollow shaft:

Solid Shaft:

$$\text{Fit Effect (inner ring)} = \left(\frac{d}{d_o} \right) \delta_S$$

Hollow Shaft:

$$\text{Fit Effect (inner ring)} = \left(\frac{d}{d_o} \right) \left\{ \frac{1 - \left(\frac{d_s}{d} \right)^2}{1 - \left(\frac{d_s}{d_o} \right)^2} \right\} \delta_S$$

Radial loss of internal clearance due to fit effects of outer race mounted in a thin wall section housing:

$$\text{Fit Effect (outer ring)} = \left(\frac{D_o}{D} \right) \left\{ \frac{1 - \left(\frac{D}{D_H} \right)^2}{1 - \left(\frac{D_o}{D_H} \right)^2} \right\} \delta_H$$

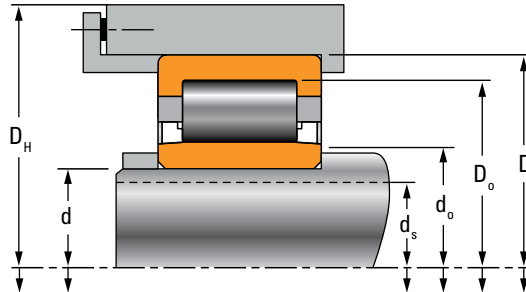

Fig. 133. Cylindrical roller bearing nomenclature.

- δ_S = Interference fit of inner race on shaft
- δ_H = Interference fit of outer race in housing
- d = Bearing bore diameter
- d_o = Mean inner-race diameter
- D = Bearing outside diameter
- D_o = Mean outer-race diameter
- d_S = Shaft inside diameter
- D_H = Housing outside diameter

TAPERED ROLLER BEARINGS

Axial loss of internal clearance due to fit effects of inner race mounted on a solid or hollow shaft:

Solid Shaft:

$$EPLoss = \left(\frac{K}{0.39} \right) \left(\frac{d}{d_o} \right) \delta_S$$

Hollow Shaft:

$$EPLoss = \left(\frac{K}{0.39} \right) \left(\frac{d}{d_o} \right) \left\{ \frac{1 - \left(\frac{d_S}{d} \right)^2}{1 - \left(\frac{d_S}{d_o} \right)^2} \right\} \delta_S$$

Outer race mounted in a thin wall section housing:

$$EPLoss = \left(\frac{K}{0.39} \right) \left(\frac{D_o}{D} \right) \left\{ \frac{1 - \left(\frac{D}{D_H} \right)^2}{1 - \left(\frac{D_o}{D_H} \right)^2} \right\} \delta_H$$

NOTE

For single-row bearings, multiply by 0.5 to get the effect on one row.

Fit Effect (one row) inner race mounted on a solid shaft:

$$EPLoss = 0.5 \left(\frac{K}{0.39} \right) \left(\frac{d}{d_o} \right) \delta_S$$

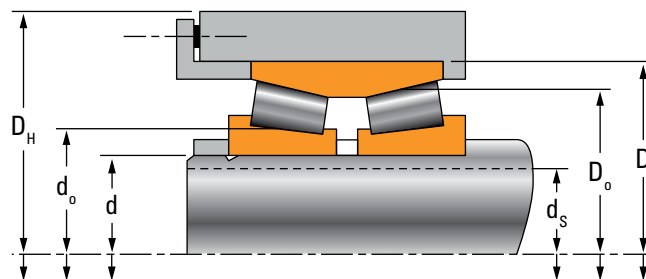

Fig. 134. Tapered roller bearing nomenclature.

δ_S = Interference fit of inner race on shaft

δ_H = Interference fit of outer race in housing

K = Bearing K-factor

d = Bearing bore diameter

d_o = Mean inner-race diameter

D = Bearing outside diameter

D_o = Mean outer-race diameter

d_S = Shaft inside diameter

D_H = Housing outside diameter

For special applications, where a very accurate setting is required (high-speed coilers, mill drives, side trimmers, slitters, etc.), the spacer width adjustment is tightly controlled based on measured component sizes that influence the interference fit. This practice, referred to as custom setting, helps minimize the influence of the interference fit range in the setting.

With a tapered-bore tapered roller bearing mounted on roll necks, the fit and final mounted setting are controlled by the final position of the cone against the backing ring. For tapered bore bearings, the interference fit is controlled within a very small tolerance range that results in a tightly controlled mounted internal clearance.

INFLUENCE OF TEMPERATURE

Bearing setting during operation is known as the operating bearing setting and is the result of change in the ambient bearing setting due to thermal expansion encountered during service.

Once a bearing is properly mounted, we must account for the steady-state condition when the system has reached its operating temperature. It is important to determine the expected operating temperature gradient between the shaft and housing in order to calculate the change of bearing internal clearance. This gradient can vary greatly from one type of application to another.

Thermal effects are approximated based on bearing size and rotational speed. In some cases, the thermal effect on operating clearance is neglected if there is no real temperature gradient across the bearing. Loss of bearing internal clearance effects can be represented by:

$$\text{Clearance loss} = \alpha (\Delta T) D_o$$

where:

α = Coefficient of thermal expansion

ΔT = Temperature difference between shaft/inner ring and housing/bearing outer race

D_o = Mean inner-race diameter

Spherical and cylindrical bearings should not operate with negative internal clearance (preload). Thermal effects should be carefully considered when selecting the bearing RIC. If the influence of temperature may lead to negative internal operating clearance, a larger RIC should be considered.

SPHERICAL AND CYLINDRICAL ROLLER BEARINGS

If the temperature differential between the inner and outer rings during operation is not known, thermal effects can be estimated for normal load conditions as follows:

Spherical Roller Bearings

$\Delta T = 13^\circ \text{C}$ (55°F) when the operating speed is greater than two-thirds of the catalog reference speed.

Cylindrical Roller Bearings

$\Delta T = 10^\circ \text{C}$ (50°F) when the operating speed is greater than two-thirds of the catalog reference speed.

Thermal effects on operating radial internal clearance are more accurately predicted based on actual operating data or with Timken modeling software.

TAPERED ROLLER BEARING

When the temperature gradient between the inner and outer rings is known, the loss of endplay is determined as follows:

$$= \alpha \Delta T \left\{ \left(\frac{K_1}{0.39} \times \frac{D_{o1}}{2} \right) + \left(\frac{K_2}{0.39} \times \frac{D_{o2}}{2} \right) \right\} \pm L$$

where:

L = Distance between bearing geometric center-lines

Use positive values for direct mounting (fig. 135) and negative values for indirect mounting (fig. 136).

α = Coefficient of thermal expansion

D_o = Mean cup diameter

ΔT = Temperature gradient between cone and cup

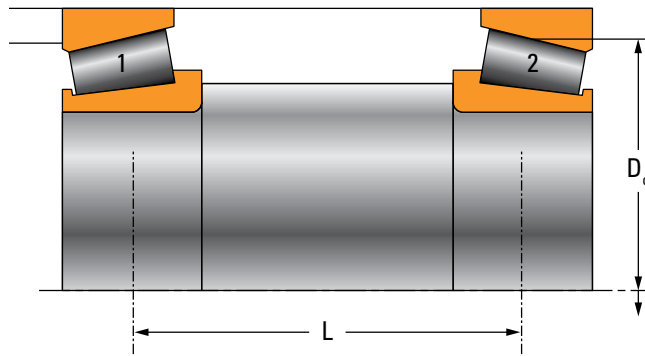

Fig. 135. Direct mounting.

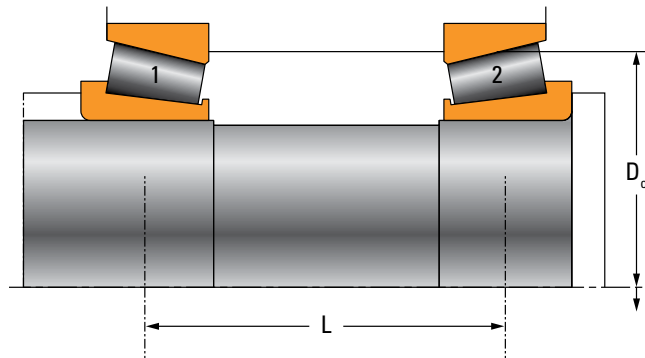

Fig. 136. Indirect mounting.

If the application operating temperatures of a tapered roller bearing are not known, lateral losses due to thermal changes at operating conditions can be estimated by calculating the bearing rib speed, and determining the corresponding default temperature gradient as given in table 6.

Rib speed = Mean rib dia. $\times \pi \times$ speed (RPM)

Estimated mean rib diameter = $(d + D) / 2$ (fig. 137)

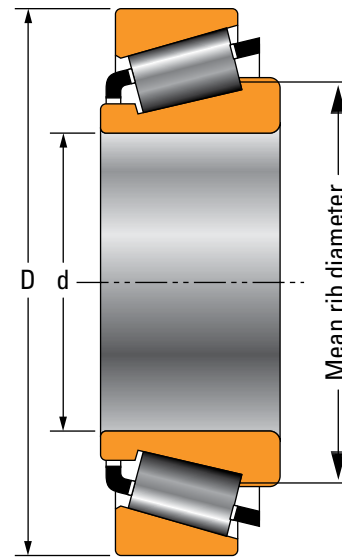

Fig. 137. Mean rib diameter estimation.

TABLE 6. DEFAULT ΔT VERSUS RIB SPEED

Rib Speed m/min. (FPM)	ΔT ° C (° F)
0 - 600 (0 - 2000)	5.5 (10)
600 - 900 (2000 - 3000)	11.0 (20)
900 - 1200 (3000 - 4000)	16.5 (30)

For rib speeds above 1200 m/min. (4000 FPM), contact your Timken engineer.

ADVANCED ANALYSIS

Timken developed several advanced analysis tools, including Syber, and heat-transfer models based on our long experience in bearing calculations. This leads to more accurate life calculations by taking into account the environment of the bearing (fig. 138). In addition, these advanced modeling tools more accurately calculate the deflections and stresses within the bearing.

For more accurate results, perform a finite element analysis (FEA) on the bearing housing. The chock is modeled so its behavior and the resultant stresses are determined under different loading conditions. Displacements are then calculated and the effect on bearing life is assessed.

MINIMUM CHOCK SECTION THICKNESS

Timken engineers have established empirical relationships for minimum chock thickness. There are situations where the designer may not be able to maintain the minimum thickness for many reasons. In such cases FEA provides insight into predicting actual stresses and deformations for a particular chock geometry subjected to maximum loads.

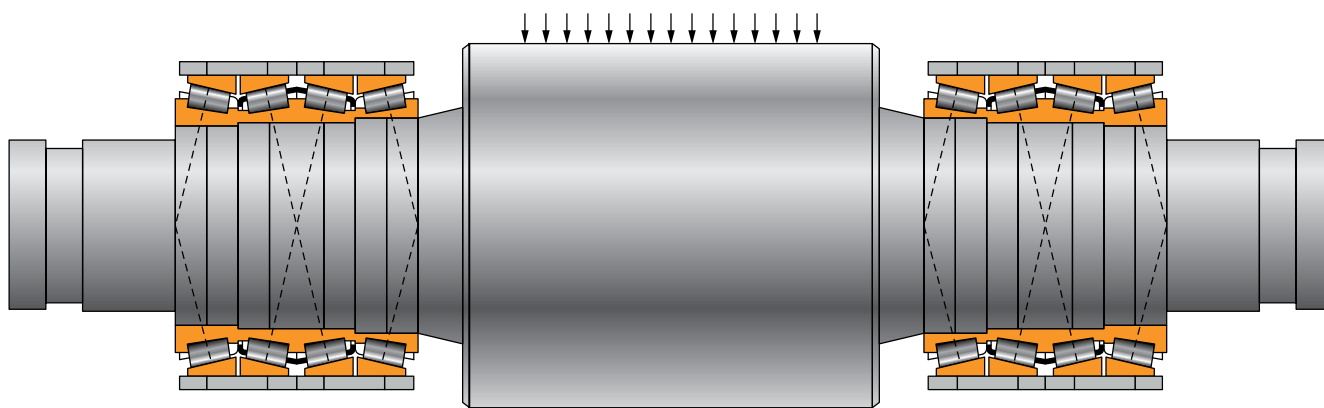

Fig. 138. Roll neck bearing-chock system as modeled in Syber (a bearing analysis tool developed by Timken).

MAXIMUM LOADED ROLLER STRESS CALCULATION

Bearing raceway stress and stress distribution are key indicators of bearing performance. Using proprietary analysis tools, Timken engineers evaluate the raceway contact stresses in the bearing. The chock stiffness obtained from FEA is used for this purpose.

When using multi-row bearings in metal processing applications, it is essential to have even distribution of loads among the rows. Uneven load sharing among the rows may lead to premature damage due to geometric stress concentration (GSC). Using FEA with Timken proprietary analysis tools, the load distribution across the bearing rows is calculated and the influence on bearing life and minimum chock sections obtained.

EVALUATION OF THE CHOCK BORE DEFORMATION

The deformation pattern in the chock bore always is uneven due to the variation in the cross section. This differential deformation impacts the bearing performance. This phenomenon is analyzed with FEA (fig. 139) and with Timken’s available proprietary analysis tools (fig. 140).

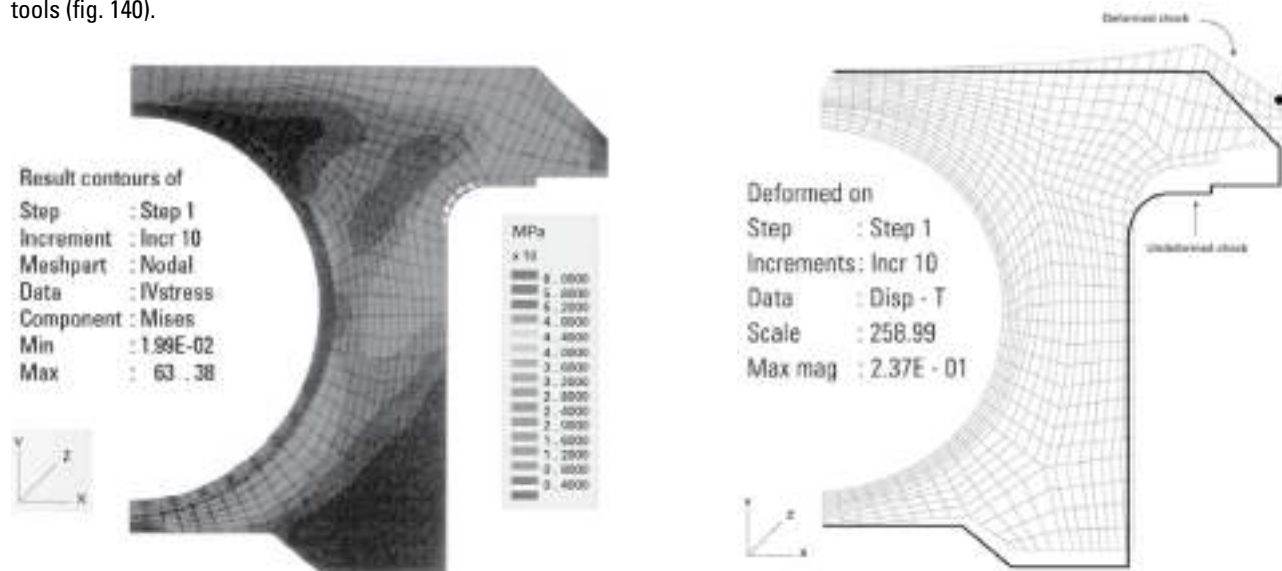

Fig. 139. Finite element chock stress analysis and finite element deformation.

In some cases, such analysis shows that even under significant chock deformation, bearing life can be greater than the expected life.

Advanced analysis is not carried out for every bearing calculation, but is restricted to critical applications. For more information on finite element analysis, please contact your Timken engineer.

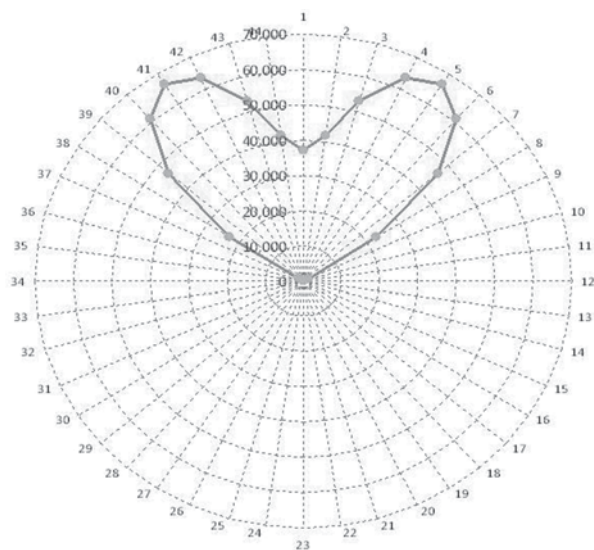
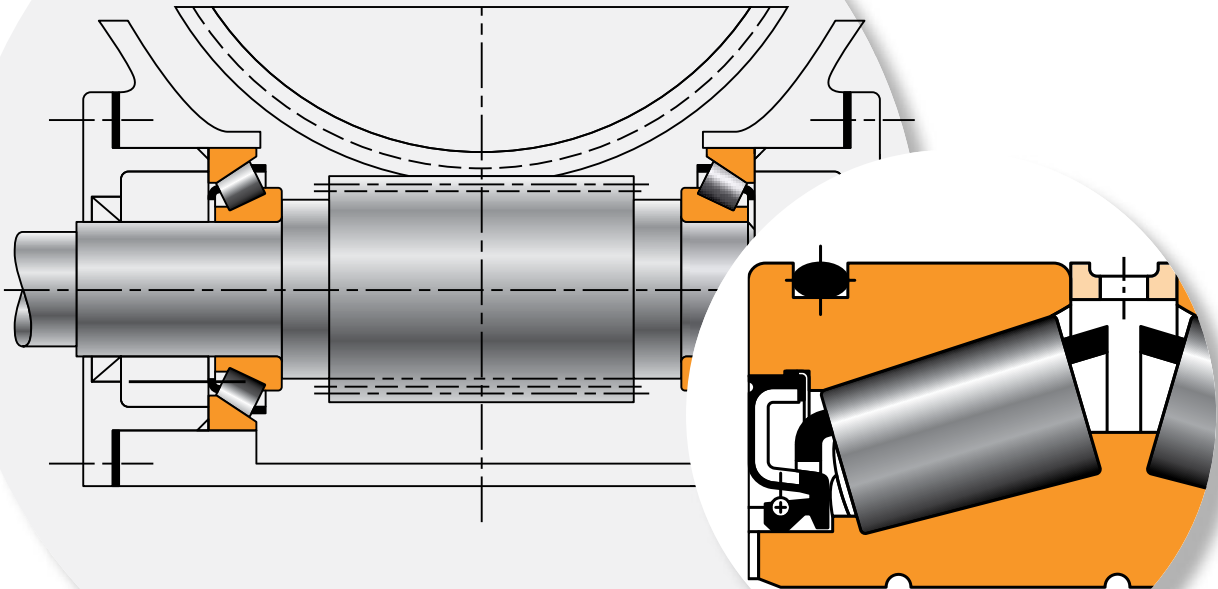

Fig. 140. Roller loads resulting from chock deflections.

LUBRICATION AND SEALING

The following topics are covered in the this section:

- Lubrication.
 - Lubrication fundamentals.
 - Main lubricant characteristics.
 - Lubrication selection.
- Sealing.
 - Sealing types.
 - Sealing systems.



LUBRICATION

Lubrication is essential to achieve successful performance and expected life from your roller bearings. Effective lubrication depends on several considerations, including the lubricant's physical and chemical properties, the quantity required and the method of delivering the lubricant to the bearing.

The presence of water and rolling solutions in roll neck applications requires robust sealing arrangements. See page 110 for further details.

LUBRICATION FUNDAMENTALS

Bearing lubricants provide the following functions:

- Minimize rolling resistance of the rolling elements and raceway by separating the surfaces.
- Minimize sliding friction occurring between rolling elements, raceways and cage.
- Heat transfer (with oil lubrication).
- Corrosion protection.

Lubrication also can function as a sealant (with grease lubrication), helping the seal keep liquid and solid contaminants out of the bearing cavity.

EUROPEAN REACH COMPLIANCE

Timken-branded lubricants, greases and similar products sold in stand-alone containers or delivery systems are subject to the European REACH (Registration, Evaluation, Authorization and Restriction of Chemicals) directive. For import into the European Union, Timken can sell and provide only those lubricants and greases registered with ECHA (European Chemical Agency). For more information, please contact your Timken engineer.

⚠ WARNING
Failure to observe the following warnings could create a risk of death or serious injury.

Proper maintenance and handling practices are critical.
 Always follow installation instructions and maintain proper lubrication.

ELASTOHYDRODYNAMIC LUBRICATION

Lubrication controls friction and wear between adjacent bearing surfaces by developing a lubricant film.

The formation of a very thin elastohydrodynamic (EHD) lubricant film between adjacent surfaces depends on the elastic deformation of these surfaces and the hydrodynamic properties of the lubricant itself.

When load applies to a bearing, the surfaces of the roller and race elastically deform and contact over a finite area. The contact between two elastic bodies (referred to as a Hertzian contact) gives rise to a pressure distribution over the region of contact with the maximum Hertzian pressure at the center (fig. 141).

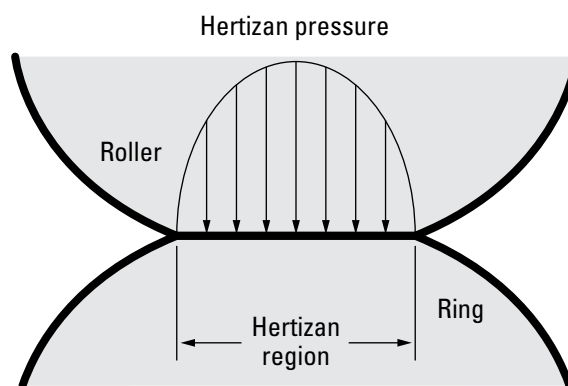

Fig. 141. Pressure distribution over contact area.

Typical maximum Hertzian pressure in rolling element bearings loaded to capacity can exceed 1400 MPa. Hydrodynamic fluid pressures are generated in the inlet region just ahead of the Hertzian deformation area (fig. 142).

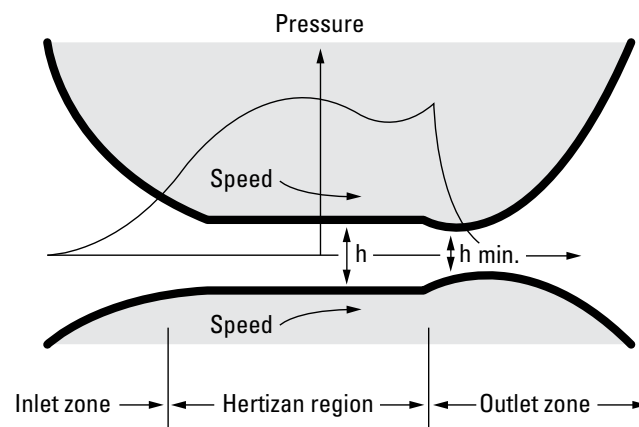

Fig 142. Hydrodynamic fluid pressure separates contact surfaces.

In the contact region, the hydrodynamic fluid pressure tries to separate the two surfaces while the load tries to force them together. The high contact pressure in the inlet zone produces a rapid rise in viscosity, which results in sufficiently high hydrodynamic film pressures that separate the two surfaces. Within the contact area, the lubricant pressure can increase to the point where the fluid may behave as a semi-solid. The effect of high pressure on increasing viscosity is not uniform for all lubricants and depends on the pressure-viscosity coefficient characteristics of the particular fluid.

FILM THICKNESS ON THE RACEWAY

The EHD lubrication mechanism is important because the lubricant-film thickness between the two contacts relates to the bearing operating conditions.

The thickness of the generated film depends on the following operating conditions (ranked by influence):

1. Surface velocity
2. Lubricant viscosity
3. Pressure-viscosity relationship

The following include the analytical relationships for calculating the minimum and the average film thickness:

Minimum film thickness (Dowson's equation):

$$h_{min.} = 2.65 \times (\mu \times V)^{0.7} \times \alpha^{0.54} \times W^{-0.13} \times R^{0.43} \times E'^{-0.03}$$

Average film thickness (Grubin's equation):

$$h = 1.95 \times \left(\frac{E'}{W} \right) \times R^{0.364} \times (\alpha \times \mu \times V)^{0.727}$$

where:

$h, h_{min.}$ = Average and minimum film thickness in m

μ = Lubricant viscosity in Ns/m²

V = Relative surface velocity in m/s

α = Lubricant pressure viscosity coefficient
($2.2 \times 10^{-8} \text{ m}^2/\text{N}$ is a usual value)

W = Load per unit length in N/m

R = $\frac{1}{1/R_1 + 1/R_2}$, R_1, R_2 surface radii of curvatures in m

E' = Reduced Young's modulus. $E' = 2.2 \times 10^{11} \text{ N/m}^2$
for steel on steel

The major factors influencing lubricant-film thickness include operating viscosity and speed. Load has less influence. The generated EHD film thickness is generally quite small at a few tenths of μm or μin . Often, the EHD film is only slightly greater than the height of the individual asperities (surface roughness) due to the roughness of the surfaces in contact.

When surfaces are not fully separated, the EHD film leaves local areas of asperity contact that are vulnerable for the initiation of surface fatigue.

The fatigue life of a bearing is related to speed, load, lubricant, temperature, setting and misalignment. Speed, viscosity and temperature primarily determine the lubricant's role in this interaction. The effect of these factors on bearing life can be dramatic. In testing, two bearing groups were subjected to constant speed and load conditions. Different film thicknesses were achieved by varying operating temperature and oil grade and, as a result, oil operating viscosity. Life was dramatically reduced at higher temperatures, with lower viscosity and thinner resultant films (table 7).

TABLE 7. RELATIVE BEARING FATIGUE LIFE VERSUS EHD FILM THICKNESS (CONSTANT SPEED – VARIABLE TEMPERATURE)

Test Group	Temperature	Visc. @ Test Temp. cSt (SUS)	EHD Film ($h_{min.}$)	Life Percent
	° C (° F)		μm (mil)	
A - 1	135 (275)	2.0 (32)	0.038 (0.0015)	13 - 19
A - 2	66 (150)	19.4 (95)	0.264 (0.0104)	100

Another test made at constant temperature on two groups of bearings (table 8) demonstrates that in this case a higher speed generates a higher film thickness and a higher life.

TABLE 8. RELATIVE BEARING FATIGUE LIFE VERSUS EHD FILM THICKNESS (VARIABLE SPEED – CONSTANT TEMPERATURE)

Test Group	Speed rev./min.	EHD Film ($h_{min.}$)	Life Percent
		μm (mil)	
B - 1	3600	0.102 (0.0040)	100
B - 2	600	0.028 (0.0011)	40

FILM THICKNESS AT SLIDING CONTACT (RIB AND ROLLER-END CONTACT)

To ensure good bearing performance, particularly in tapered roller bearings, the contact area between the large end of the roller and the cone rib also must be separated by an adequate lubricant film. The contact stresses at the rib and roller-end juncture are much lower than those developed on the bearing raceways (fig. 143). However, there are applications where the lubricant film in the cone rib/roller-end contact may be insufficient for preventing asperity contact. If severe enough, this can result in scoring and/or welding of the asperities. This may be related to speed, oil viscosity, load or inadequate lubricant supply to the cone rib/roller contact.

If you expect severe operating conditions, using a lubricant with an extreme-pressure (EP) additive may help prevent scoring damage in the cone rib/roller-end contact. EP additives are chemically complex materials that, when activated by localized high temperatures, form a low shear-strength film at the contact that helps prevent scoring.

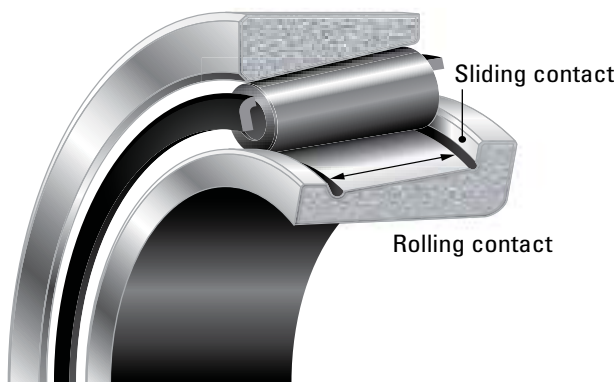

Fig 143. Illustration of rolling and sliding contact.

LAMBDA RATIO (λ)

Lubrication-film thickness is a very important factor in maintaining the performance of a bearing. Film thickness, combined with the composite surface finish of the roller and raceway in contact, are used to determine the lambda ratio. The lambda ratio is used as a life adjustment factor for lubrication in bearing system analysis and proves helpful in diagnosing application problems.

$$\lambda = \frac{\text{Film thickness}}{\text{Composite roughness of two surfaces}}$$

where:

The composite roughness is the sum of the two surfaces in contact.

The optimal lambda ratio for a bearing and lubricant depends on the application's operating conditions. For typical rolling bearing applications, a λ ratio of 1.5 is considered to be sufficient to separate the contact surfaces and indicates that the lubrication film thickness is 1.5 times the combined asperity height. A λ ratio less than 1.0 may allow asperity contact to occur, which under extreme application conditions could potentially lead to roller and race peeling damage (fig. 144).

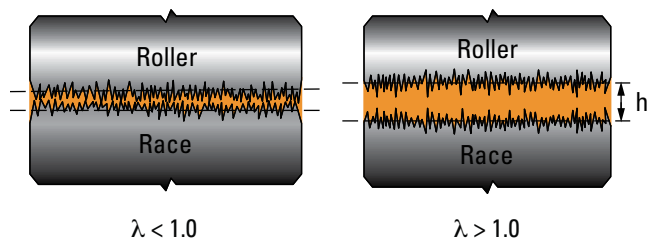

Fig. 144. Visual representation of film thickness (h) in conditions where the lambda ratio is less than and greater than 1.0.

Thickness of the generated film depends on operating conditions such as:

- **Temperature:** Higher temperatures reduce the viscosity of the lubricant.
- **Lubricant viscosity:** Heavier lubricants increase total friction in the application.
- **Surface finish:** Rougher finishes may not be completely covered by the lubricant.

MAIN LUBRICANT CHARACTERISTICS

VISCOSITY

Viscosity is the most important physical property of a lubricant. It is a measure of a lubricant's flow characteristics and relates to its consistency. Viscosity varies inversely with temperature; the lower the temperature, the higher the viscosity (fig. 145).

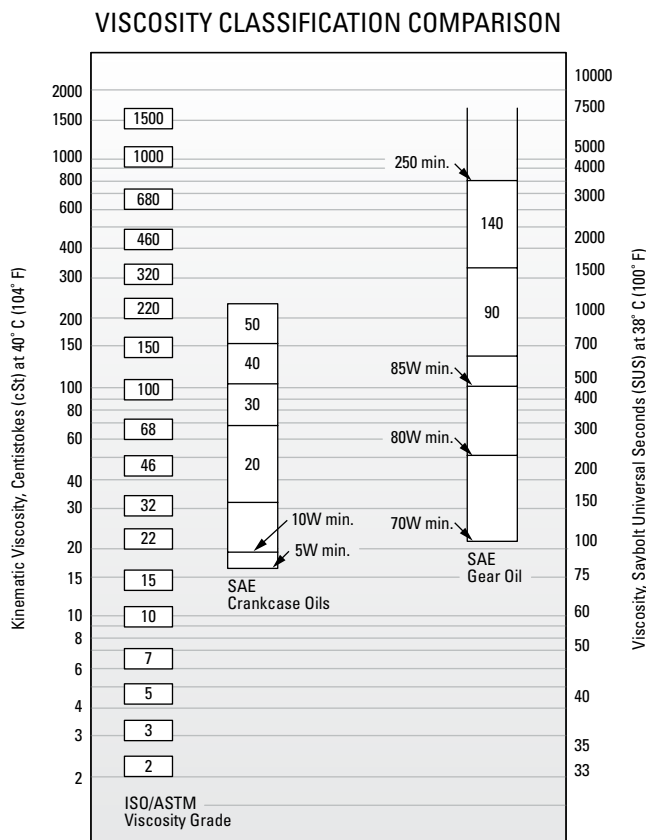

Fig. 145. Comparison between ISO/ASTM grades (ISO 3448/ASTM D2442) and SAE grades (SAE J 300-80 for crankcase oils, SAE J 306-81 for axle and manual transmission oils).

VISCOSITY INDEX (V.I.)

The viscosity index helps define the rate of viscosity change with fluctuations in temperature (fig. 146). Ideally, lubricants used in metals applications should have a high viscosity index so they can perform successfully across a wide range of operating temperatures, from a cold start to maximum running temperatures.

PRESSURE VISCOSITY COEFFICIENT

Pressure viscosity is the change of a lubricant's viscosity under pressure. It is calculated as:

$$\mu = \mu_0 e^{\alpha\sigma}$$

where:

μ = Viscosity at contact pressure

μ_0 = Viscosity at atmospheric pressure

e = Base of natural logarithm ($e \approx 2.718$)

α = Lubricant pressure-viscosity coefficient

σ = Contact pressure

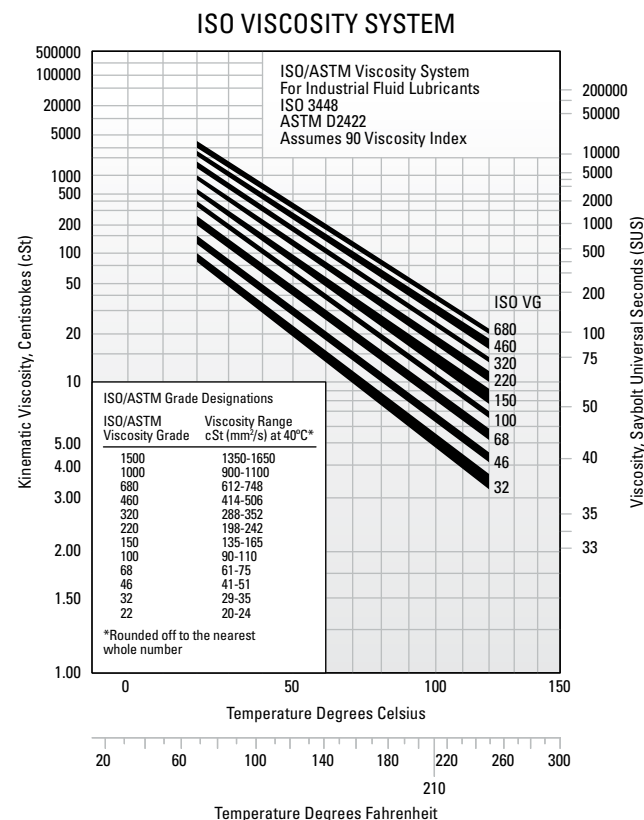

Fig. 146. Viscosity change with temperature.

LUBRICANT ADDITIVES

Chemical additives are often used to improve specific lubricant properties, such as viscosity index. However, inorganic additives have no significant benefits in most bearing applications. Fatigue testing shows that additives may have positive or negative impact on bearing life. When using additive, take care to consider the possible negative consequences on bearing performance.

Types of lubricant additives include:

- **Oxidation inhibitors:** Interrupt oxidation by absorbing oxygen.
- **Rust/corrosion inhibitors:** Block corrosion by creating a barrier to water or emulsifying water.
- **Demulsifiers:** Separate water from lubricant.
- **Viscosity-index improvers:** Decrease viscosity sensitivity to temperature.
- **Pour-point depressants:** Lowers the point at which a lubricant will pour or flow.
- **Anti-wear agents:** Phosphorous compounds used in hydraulic fluids to reduce wear.
- **Extreme-pressure additives:** Sulphur-phosphorous compounds activated by localized high temperatures. Ideal for gears or other sliding contact applications.
- **Tackiness agents:** Improve adhesive properties.

LUBRICATION SELECTION

Proper lubrication depends on loads, speeds, temperatures, environmental conditions and the type of lubrication-delivery system. Both grease and oil have advantages and disadvantages that you should consider when selecting the right lubricant for your application.

GREASE LUBRICATION

Grease is a semi-solid product obtained by dispersion of a thickener in a base oil. Therefore, grease properties are linked to the nature of the gelling agent and to the liquid lubricant. Most grease types also contain additives to obtain specific characteristics, such as water resistance or extreme-pressure capabilities.

Many different types of grease exist, depending on the thickener and the base oil used. To select the right grease, consider its EHD film thickness in operating conditions. This film thickness is directly linked to the viscosity of the base oil.

Advantages:

- Lower system cost.
- Additive sealing properties.
- Less probability of leakage.
- Improved protection in case of extended non-running periods.

Disadvantages:

- Speed limitations.
- Heat dissipation capability.
- Retains contamination particles.
- Greater maintenance time for cleaning.
- Grease disposal.

Starting torque in grease-lubricated applications typically increases significantly at cold temperatures. Starting torque is primarily a function of the rheological properties of the grease (flow characteristics versus temperature).

The high-temperature limit for grease is generally a function of the thermal and oxidation stability of the base oil in the grease and the effectiveness of the oxidation inhibitors.

Grease type

Grease-lubricated steel mill equipment, roll necks and auxiliary equipment, such as table rolls, can be lubricated with EP steel mill grease. Because of the nature of metal mill equipment, the grease must be a heavy-duty product capable of withstanding heavy loads and abnormal shock loading.

Suggested EP steel mill grease properties

Soap type: Lithium, calcium, sulfonate or equivalent

Consistency: NLGI No. 1 or No. 2

Additives: Corrosion and oxidation inhibitors
EP additive⁽¹⁾

Base oil: Solvent-refined petroleum or synthetic oil

Base oil viscosity: Usually 320 to 460 cSt (at 40° C [104° F])

Viscosity index: 80 minimum

Pour point: -10° C (14° F) maximum

⁽¹⁾ ASTM D-2509: 15.8 kg (35 lb) minimum Timken OK Load

EP steel mill grease contains EP additives to prevent scoring under severe service conditions. The grease should have excellent mechanical and chemical stability and should not readily emulsify or washout in the presence of water or mill emulsion. It should contain inhibitors to provide long-term protection against grease oxidation in high-temperature applications and protect the bearings from corrosion in the presence of moisture. The grease should not contain materials corrosive or abrasive to roller bearings or seal material.



Fig. 147. Timken grease offering.

Required initial grease quantity

To avoid excessive heat generation, don't over grease the bearing. The required quantity of grease is based on the free internal volume of the bearing,

Calculated as:

$$V = \left(\frac{\pi}{4} \times (D^2 - d^2) \times T \right) - \frac{M}{A}$$

Where:

V = Free volume in the bearing (cm³ [in.³])

D = Outer-race O.D. (cm [in.])

d = Inner-race bore (cm [in.])

T = Overall width (cm [in.])

M = Bearing weight (kg [lb.])

A = Average steel density: 0.0078 kg/cm³ (0.282 lb./in.³)

To determine the corresponding weight of grease, approximate the grease density to 0.9 kg/dm³ (0.032 lb./in.³).

Roller bearings are filled with grease from one-third to one-half of their free internal volume, depending on the application. For speeds below 10 RPM, fill the bearing 100 percent of the free internal volume. This also applies to the space adjacent to the bearing. However, this is not applicable to applications where synthetic greases might be used or where the builder has defined a specific lubrication cycle.

Regreasing

Over-greasing generates excessive heat and the bearing can burn up. After initially filling the bearing with grease, consider the following parameters to determine the normal regreasing requirements:

- Temperature.
- Seal efficiency.
- Contamination.

General guidelines for regreasing depend on the efficiency of the sealing system and are based on experience. It is general practice to regrease roll neck bearings at every roll change for unsealed bearings and at every bearing inspection (about 500 to 1000 hours) for sealed roll neck bearings.

When replenishing grease, we suggest the following guidelines:

- **Open (un-sealed) bearing:** one-third of initial fill every roll change.
- **Sealed bearing:** one-third of initial fill every bearing inspection.

Use one-third of initial fill with the bearing in chock and 100 percent of initial fill if the bearing has been cleaned if refilling between normal maintenance operations.

Grease lubrication layout for low- and medium-speed mills

Figs. 148 and 149 show the arrangement normally used with a centralized grease lubrication system. The lubricant is applied to the bearing through the ports (1 and 2). Grease is applied to the closure seals through port (3) for the sealing. Air-relief vents are provided near the top of the chock, through fittings (4).

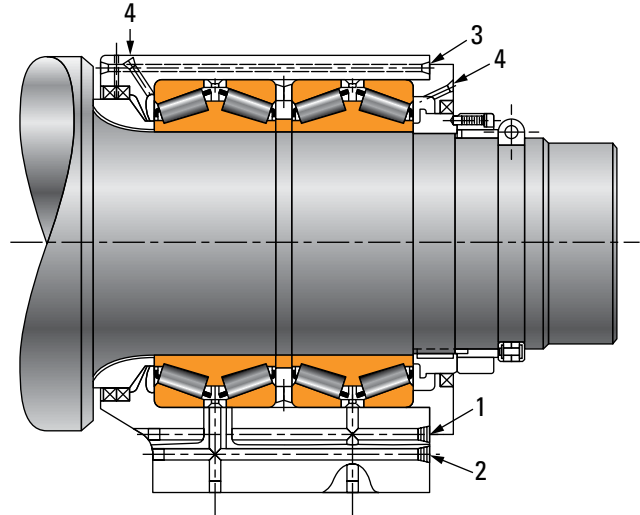

Fig. 148. Chock lubrication and venting layout for TQOW bearings in low-medium speed mills (section view).

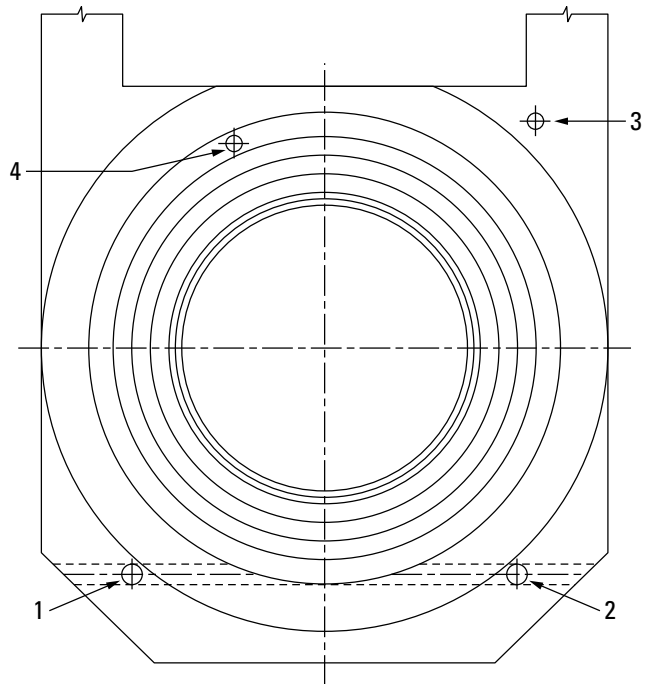

Fig. 149. Chock lubrication and venting layout for TQOW bearings in low-medium speed mills (front view).

Compatibility of grease

Avoid mixing greases with differing grades or additives. This may cause interactions that degrade grease properties. Maintenance personnel and end users also should make sure that when switching from one bearing grease type to another, the former should be completely cleaned out before the new grease is applied.

NOTE

Mixing greases can result in improper bearing lubrication. Always follow the specific instructions of your equipment supplier.

Timken grease offering

We offer a wide range of lubricants and delivery devices for metal production facilities (fig. 150).

Our full line of lubricants includes greases specifically formulated for mill applications. We also offer single- and multi-point lubricators that simplify maintenance operations and help reduce occurrences of bearing damage or total seizure due to insufficient lubrication. Contact your Timken engineer for more information on specific formulas available.



Fig. 150. Timken lubrication offering.

OIL LUBRICATION

There are five basic types of oil lubricating systems used in Timken bearing mill applications: air-oil lubrication, oil-mist lubrication, oil bath, oil splash and forced-feed oil lubrication. The selection of a particular type of system is based on thermal considerations or the ability of the system to remove the heat generated by the bearing and/or the gear system in the application.

Advantages:

- Heat dissipation capability (while circulating).
- Removes contamination particles.
- Controllable oil levels or flows.
- Cooling and filtering possibilities.
- Oil inlets (jets) can be directed on critical locations.

Disadvantages:

- Higher system cost.
- Need for improved sealing systems to guard against leakage.

Air-oil lubrication systems

In recent years, air-oil lubrication has become a popular solution for multi-row tapered (fig. 151) and cylindrical (fig. 152) roll neck bearings.

Typically, the air-oil system may be safely operated with a maximum rolling speed of about 2100 m/min. (6900 ft./min.). Higher-speed applications may require special attention and testing.

The advantage of an air-oil lubrication system is its reliability to supply a constant quantity of oil to the bearings at all times. This reliability is essential for a lubrication system designed to consume small quantities of oil. It also is more environmentally friendly than oil-mist lubrication.

The oil is transported along the inside wall of a pipe and is distributed via nozzles mounted in the chock. Oil droplets are effectively distributed among the different lubrication points in the chock. The quantity of oil entering through the main entry hole of the chock needs to be evenly shared among the different bearing rows and seal-lip positions.

The air pressure inside the bearing chamber (about 0.2 to 0.3 bar) can also be an added barrier against the ingress of the rolling coolant, depending on the sealing and/or venting system.

If upgrading from an oil-mist to air-oil lubrication system, pay particular attention in removing the oil-mist nozzles from the bearing or from the chocks.

Typical layouts

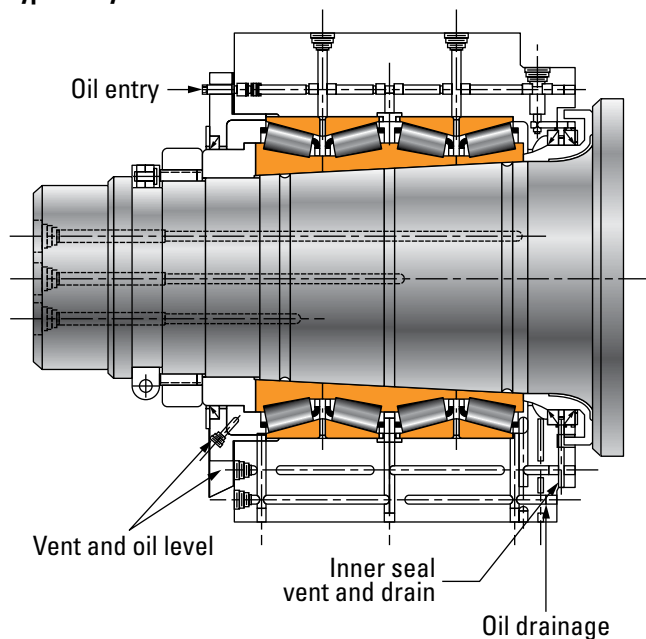

Fig. 151. Air-oil layout with TQIT type bearings (layout is the same for TQO type bearings).

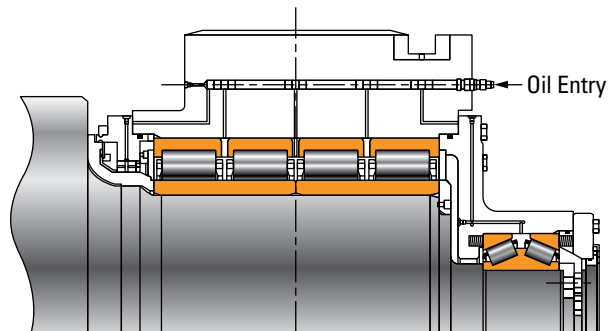

Fig. 152. Air-oil layout with four-row cylindrical roller bearing and TDIK type bearings.

Oil quantities

For heavily loaded and low-speed mills, air-oil lubrication systems allow very high oil viscosities to be selected (about 460 cSt at 40° C [104° F] or more) as the oil no longer has to be in mist form.

Oil consumption is usually lower, according to equipment suppliers, when compared with the quantity of oil consumed by an oil-mist system. These quantities are based on equations developed by air-oil systems suppliers and should be discussed and defined with the supplier.

Obtain an approximation of the oil-flow rate by using the following equation:

$$V = 0.00005 \times \text{bearing O.D. (mm)} \times \text{bearing width (mm)}$$

$$Vm^3/hr. = 0.002 \times \text{bearing O.D. (in.)} \times \text{bearing width (in.)}$$

As in all other lubrication systems, the proper air-oil quantities are finally set when the mill is tested in operation. The initial calculation primarily defines the size of the installation.

The quantity of oil required must be evaluated to effectively lubricate the bearing races and rollers. This minimum quantity of oil is based on the surface of the bearing races to be coated. The risk of having insufficient oil available at any moment is reduced by the presence of the minimum oil level in the bottom of the chock in the safety oil sump, which is usually specified with this type of lubrication system.

The position of the oil level in the bottom of the chock must be properly controlled to avoid additional heating due to oil churning (particularly for high-speed mills). Usually the level should be just above the bearing outer races, as shown in fig. 153.

The small quantities of oil used in air-oil lubrication systems are not capable of removing the heat generated in the bearing system of high-speed mills. The equilibrium temperature will depend almost entirely on the heat dissipation capacity of the bearing's surrounding parts (chocks and rolls) to be able to operate at a stabilized bearing operating temperature that is still considered safe. Our experience shows that our bearings can operate safely at temperatures up to 130° C (266° F).

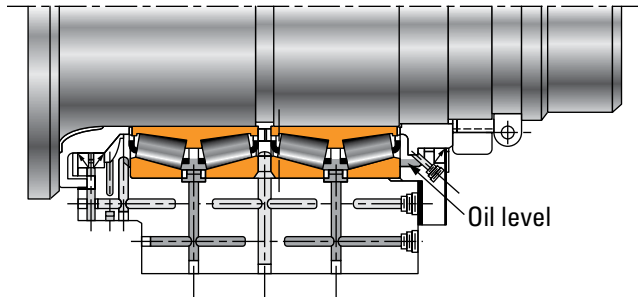

Fig. 153. Proper oil level in an air-oil lubrication system.

Oil characteristics for air-oil systems

Base oil:	Solvent-refined, high viscosity index petroleum oil
Additives:	Corrosion and oxidation inhibitors, EP additive ⁽¹⁾
Viscosity index:	80 minimum
Pour point:	-12° C (40° F) maximum
Viscosity grade:	320 – 460 cSt at 40° C suggested

⁽¹⁾ ASTM D-2509: 15.8 kg (35 lb) minimum Timken OK Load

Oil-mist lubrication systems

On roll necks, oil-mist lubrication systems are used when conventional grease lubrication is no longer safe and reliable due to the operating speeds of the work roll and/or backup roll bearings.

In recent years, it has become a less-common system due to environmental considerations, but it is still used on some older mills.

The oil is atomized into fine particles (about 2 µm [80 µin.]) in an oil-mist generator (fig. 154). Next, the oil is conveyed by the low-velocity and low-pressure (nominal 0.05 bar) air stream to the nozzles located in the drillings provided in the chocks. These nozzles (usually three or four per chock) should be located in the chock bore in line with the lubricant entries provided in the bearings and seals, as shown in fig. 155 (on next page). These nozzles also can be located in the bearing outer ring.

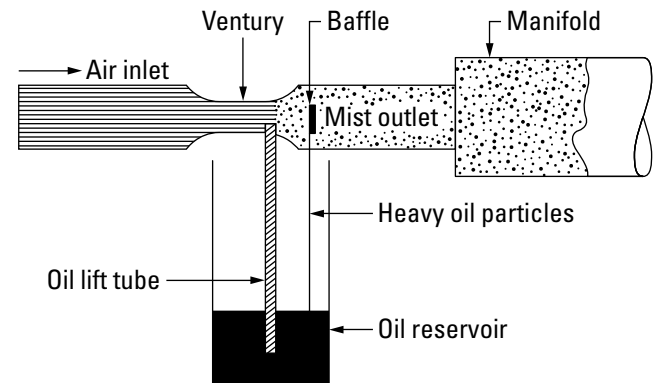

Fig. 154. Principle of the oil-mist generation.

Typical layout

The nozzle ensures proper distribution and control of the amount of oil-mist. This is achieved by the number/length/size of the holes per nozzle and the distribution of these nozzles among the various points to be lubricated in a given chock (usually two per bearing and one or two for the seal lips).

The required quantity of oil is not specifically calculated based on heat generation within the bearing, but rather according to the size and the number of rows of the bearing. However, the minimum expected amount of oil to be consumed is established based on the oil-mist density defined by the manufacturers of the oil-mist generators.

Additionally, nozzles increase the size of the fine oil particles suspended in the low-velocity air stream just before entering the bearing. This is achieved by the turbulence created by the velocity increase when the oil mist passes through the nozzle holes, or what are otherwise called reclassifying nozzles. It is important to provide adequate venting in the chock, so as not to disturb the pressure drop through the nozzle holes and the mist velocity increase. The vent-holes area should be at least twice the area of all nozzle holes in the system.

The location of these venting holes will determine the minimum oil level within the bearing. This oil level is required during the start-up phase. It also is suggested to ensure that this level exists when starting the mill after an extended long period of non-operation.

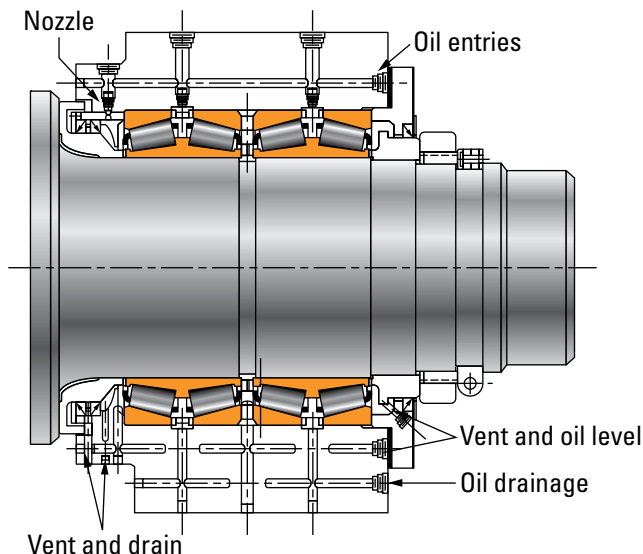

Fig. 155. Typical oil-mist passages.

Oil characteristics (for oil-mist systems)

Base oil:	Solvent-refined, high viscosity index petroleum oil
Additives:	Corrosion and oxidation inhibitors, EP additive ⁽¹⁾
Viscosity index:	80 minimum
Pour point:	-12° C (10° F) maximum
Viscosity grade:	220 – 320 cSt at 40° C (104° F) suggested

⁽¹⁾ ASTM D-2509: 15.8 kg (35 lb) minimum Timken OK Load

Oil-bath and oil-splash lubrication systems

This is the simplest type of lubrication system, but also the most limited. The bearings are partially submerged in a static oil reservoir, or oil bath. These systems are typically suitable for low- and moderate-speed applications (less than 18 m/s [3400 ft./min.] rib speed) and have limited ability to transfer heat. Sealing plays a major role in the proper functioning of oil-bath systems since a minimum oil level must be maintained (fig. 156 on next page). Take proper care when selecting seals for their equipment. It is suggested to provide a provision for a sight glass to monitor the oil level at any point in time particularly in critical applications.

Oil-bath and oil-splash lubrication systems are found on drives, pinion stands and coilers. Oil refill is not frequently required in these systems. It is very important to ensure effective sealing to maintain an adequate oil level and prevent contamination.

You can improve heat dissipation if the oil is splashed on the entire inner surface of the housing. Most of the time, the gears will handle this job. The goal is to recapture the oil and channel it to the bearing. You can achieve this by the use of oil-catching devices. To maintain an oil level in the bearing, you can use oil-dam systems, as shown in fig. 157 on next page.

Oil-splash systems can be used at moderately high bearing speeds (up to 20 m/s [3900 ft./min.] rib speed) if properly designed with a large oil reservoir and large cooling surfaces. The housing design also will play a major influence on the degree of cooling provided.

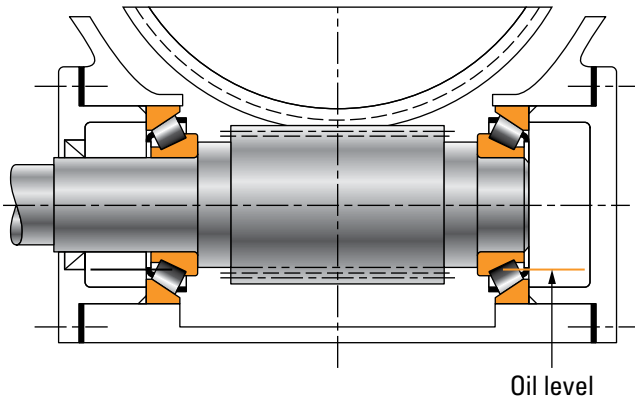

Fig. 156. Proper oil level in an oil-bath lubrication system.

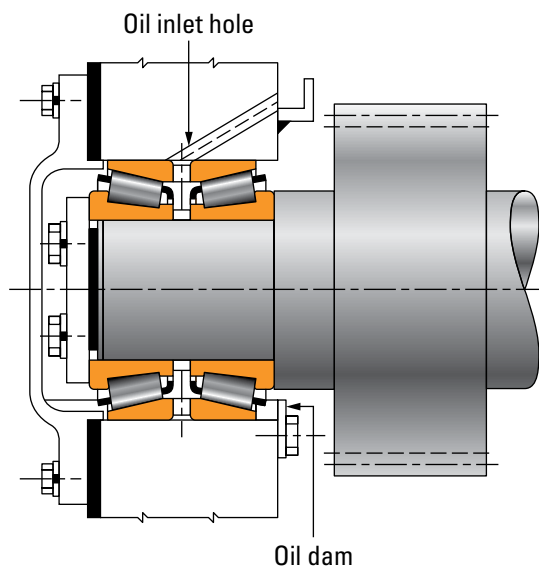

Fig. 157. Examples of catch trough and oil dam.

Oil characteristics (for oil-bath and oil-splash)

The oil is primarily selected from a viscosity standpoint that is dictated by the application's speed, load and environmental factors.

Since viscosity varies inversely with temperature, the viscosity value must always be defined in relation to the expected operating temperature, which also is linked to the initial oil viscosity. In most of the above mentioned applications, using an oil-bath system with petroleum-type oil (viscosity between 220 and 460 cSt at 40° C [104° F]) is generally suggested. Additives validated to avoid negative impacts on bearing performance can be used to improve the oil behavior. The most common additives include:

- EP additives to prevent scoring under boundary lubrication conditions.
- Oxidation inhibitors for increasing lubricant service life.
- Rust or corrosion inhibitors to protect bearing surfaces.
- Anti-wear agents.

In gear drive applications, oil choice is often guided by the gearing needs.

Forced-feed oil lubrication systems

Forced-feed lubrication systems are used in applications in which a high amount of heat needs to be dissipated due to the operating parameters, like in medium- to high-speed gear drives. Oil flow also can be gradually adapted to the required level of heat dissipation. If necessary, you can add an oil-cooling unit.

In certain applications or environments, you might need to pre-heat the oil to avoid start-up of machinery with too thick oil. In a typical oil-circulation system (fig. 158), oil is pumped from a central reservoir to each bearing. In tapered roller bearing applications, to take advantage of the natural pumping action, the oil is introduced at the small end of the bearing and drained away at the large end.

This kind of circulation can be used for rib speeds up to 25 m/s (5000 ft./min.). If the rib speed exceeds this value, as on very high-speed drives or coilers, forced-feed systems with oil jets are used (fig. 159). The position of the jets allow them to direct the oil to the space between the cage and the small rib.

HEAT GENERATION AND DISSIPATION

Heat generation

Churning of excess lubricant can be the major source of heat if filling instructions are not properly followed or if lubrication intervals are not properly maintained. In a properly lubricated bearing, the majority of heat is developed between the rolling elements and the raceways.

The heat generated by a bearing is defined by the following formula (product of running torque and bearing speed).

$$Q_{gen} = k_4 n M$$

where:

$$Q_{gen} = \text{Generated heat} \quad \text{W (BTU/min.)}$$

$$M = \text{Running torque} \quad \text{N.m (lb.in.)}$$

$$n = \text{Rotational speed} \quad \text{rev/min.}$$

$$k_4 = 0.105 \text{ for } Q_{gen} \text{ in W when } M \text{ in N.m}$$

$$= 6.73 \text{ for } Q_{gen} \text{ in BTU/min. when } M \text{ in lb.in.} \times 10^{-4}$$

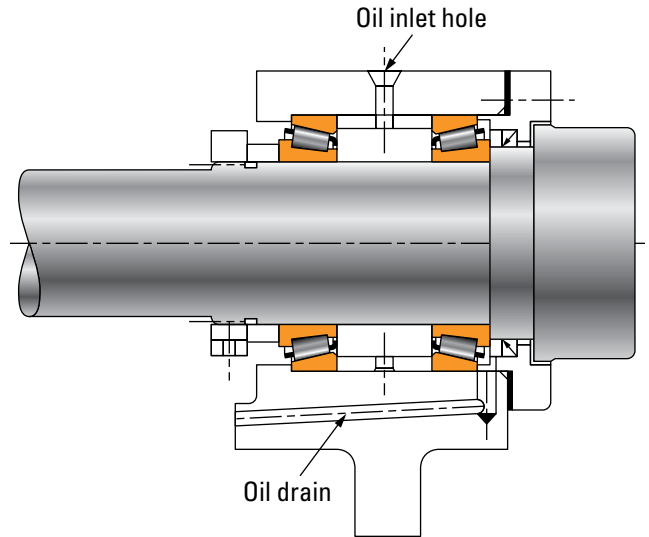

Fig. 158. Oil circulation system.

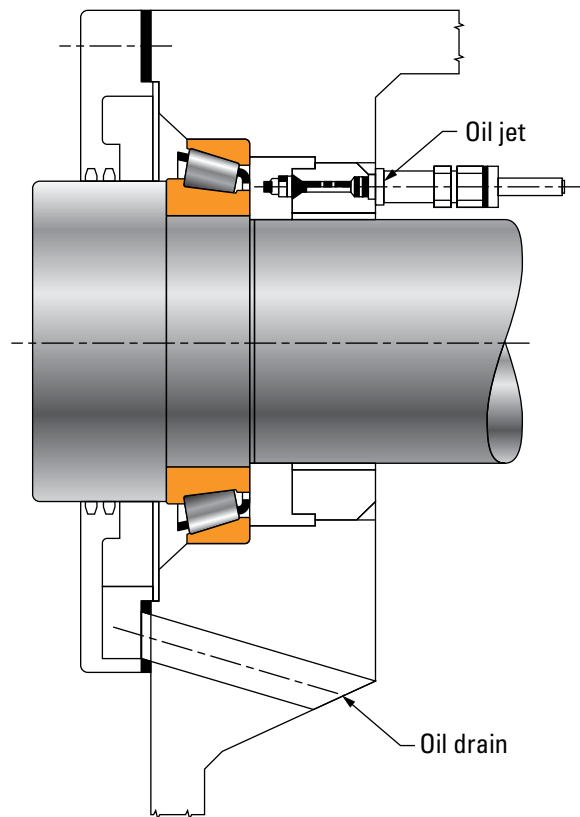

Fig. 159. Forced-feed oil system with oil jet.

Heat dissipation by the circulating oil

In a circulating-oil system, the oil removes the majority of the heat. The following equation represents a good approximation of the amount of heat removed by the circulating oil if the lubricant properties are not known for petroleum oils. Consult your lubricant provider for specific values.

$$Q_{oil} = k_5 f (\theta_o - \theta_i)$$

where:

k_5 Dimensional factor to calculate heat carried away by a petroleum oil

$$k_5 = 28 \text{ for } Q_{oil} \text{ in W when } f \text{ in L/min. and } \theta \text{ in } ^\circ\text{C}$$

$$= 0.42 \text{ for } Q_{oil} \text{ in BTU/min. when } f \text{ in U.S. pt./min. and } \theta \text{ in } ^\circ\text{F}$$

Q_{oil} Heat dissipation rate of circulating oil W (BTU/min.)

θ_i Oil inlet temperature $^\circ\text{C}$ ($^\circ\text{F}$)

θ_o Oil outlet temperature $^\circ\text{C}$ ($^\circ\text{F}$)

f Lubricant flow rate L/min.
(U.S. pt./min.)

If the lubricant flow is unrestricted, the flow rate can freely pass through the bearing. The quantity of lubricant effectively cooling the bearing depends on bearing size and internal geometry, direction of oil flow, bearing speed and lubricant properties.

In a splash or oil-bath lubrication system, heat is transferred within the bearing through convection. The heat-dissipation rate with this lubrication method can be enhanced through the use of housing-cooling coils, a housing sump or a housing-splash system.

INFLUENCE OF CONTAMINANTS

Abrasive particles

The primary cause of bearing damage in a clean environment is the fatigue of the races where rolling contact occurs. However, when particle contamination enters the bearing system, it is likely to cause damage such as bruising and peeling, which will shorten bearing life.

Under these conditions, case-hardened steel is preferred, as it is more tolerant to debris than through-hardened steel. Furthermore, when dirt from the environment or metallic-wear debris from some component in the application is allowed to contaminate the lubricant, wear becomes the predominant cause of bearing damage (fig. 160).



Fig. 160. Bearing damage due to abrasive particles.

Bearings operating in a contaminated lubricant exhibit a high initial rate of wear. With no further contaminant ingress, this wear rate quickly diminishes as the contamination particles are reduced in size when they pass through the bearing contact area during operation.

In general, the important parameters influencing bearing wear are contaminant particle size, concentration, hardness and lubricant-film thickness. Increases in all of these parameters except film thickness will increase bearing wear. Increasing lubricant viscosity reduces bearing wear for a given contamination level.

Filtration equipment is suggested for oil applications where particle contamination is likely to have a significant effect on bearing performance. Nominally, 40 μm (1600 $\mu\text{in.}$) rated filters are common for most industrial applications.

Water and rolling emulsions

In lubricating oils or greases, dissolved or suspended water and rolling emulsions make a negative impact on bearing life.

Water and rolling emulsions can cause corrosion and bearing etching when the bearings are stationary. See page 122 for further details.

Water and rolling emulsions also are detrimental to bearing fatigue life. The exact life mechanism is not fully understood, but it has been suggested that water and rolling emulsion enters microcracks in the bearing races, which are caused by repeated stress cycles. This then leads to corrosion and hydrogen embrittlement in the microcracks, which accelerates crack propagation.

Using grease with good water-absorption properties can mitigate the severity of bearing corrosion.

SEALING

To maximize the service life of a bearing assembly, efficient sealing is imperative. Dynamic seals, which are key components in a bearing system, have two functions:

- To exclude the contaminants from the bearing system.
- To retain the lubricant inside the bearing.

The proper seal design depends on which of these two functions is more critical, as well as bearing operating conditions.

To select the proper seal design for any Timken bearing application consider:

- The type of lubricant.
- The foreign material to be kept out of the bearing cavity.
- The speed of the application.
- The expected operating temperature.
- The type of application.
- Other general environmental and operating conditions.

Foreign material, such as dust, scale or any hard, abrasive substance, will act as a lapping agent and cause rapid bearing wear. Water-based rolling solution (generally acidic) will deteriorate the lubricant and seals, which results in bearing damage as well as lubricant washout.

The seal material needs to be checked for compatibility with the lubricant additives and the rolling solutions, whenever a change is made to lubricant, rolling solutions or seal material type.

SEAL TYPES

CONTACTING SEALS

With contacting or rubbing seals, a physical contact occurs between the sealing members. They are frequently used in the low- to medium-speed ranges where the heat generated by the contact forces is acceptable.

During operation, a lubrication film must exist between the seal lip and the seal seat. Otherwise, seal damage will quickly appear.

There are two basic types of contacting seals – radial lip seals and face seals (fig. 161).

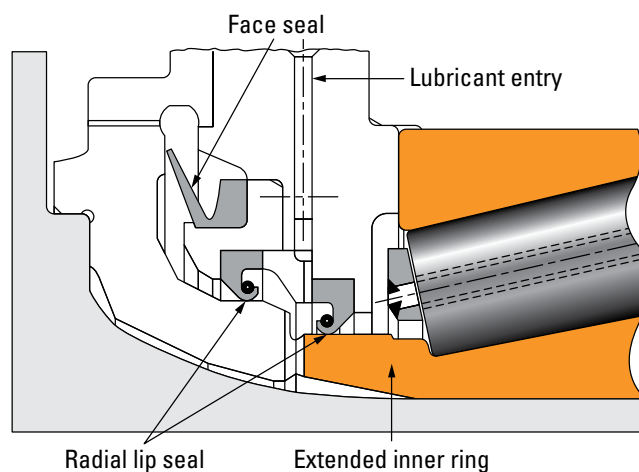

Fig. 161. Radial and face seal-lip configuration.

Radial seal lips used in the rolling mill industry are mainly manufactured with three different materials – Nitrile (NBR), hydrogenated Nitrile (HNBR), and fluoroelastomer (FKM) or (DuPont™ Viton®). These three materials can be used either for mineral oils or for synthetic oils.

Nitrile seals are used for lip-seat speeds up to 14 m/s (2800 ft./min.) and operating temperatures up to 100° C (212° F). Hydrogenated Nitrile seals offer better performance and handle operating temperatures up to 125° C (257° F). For applications that require high thermal stability and chemical resistance, we suggest using fluoroelastomer seals for operating temperatures up to 160° C (320° F).

A correct lip efficiency is obtained with a lip-seat hardness of 45 to 60 HRC and a roughness Ra of 0.25 to 0.50 μm (10 to 20 μin.). The seal seat must be plunge-ground to avoid any grind lead. These suggestions help to establish and maintain a stable lubricant film, preserve the surface texture and prevent excessive seat wear.

DuPont™ and Viton® are registered trademarks of E. I. du Pont de Nemours and Company or its affiliates.

Static seals

To obtain complete sealing of a bearing, consider utilizing static seals between non-rotating parts. O-rings or compressible gaskets situated between the outer ring (cup) cover and the housing (chock) help achieve this.

NON-CONTACTING SEALS

Non-contacting seals include various types of labyrinth (fig. 162) and hydrodynamic seals that maintain a clearance between the sealing elements. Leakage through these seals depends on the amount of clearance and the seals' ability to reduce the kinematic energy of the fluid that may enter the labyrinth.

Labyrinth seals are available in a variety of configurations. Theoretically, labyrinths act as leakage-reduction mechanisms, but not leakage-elimination mechanisms. Labyrinth seal leakage rates are directly proportional to radial clearance. Therefore, these clearances should be kept to a minimum. Non contacting seals often are proposed for high-speeds (above 25 m/s [5000 ft./min.]) where elastomeric contact seal-lips cannot be used.

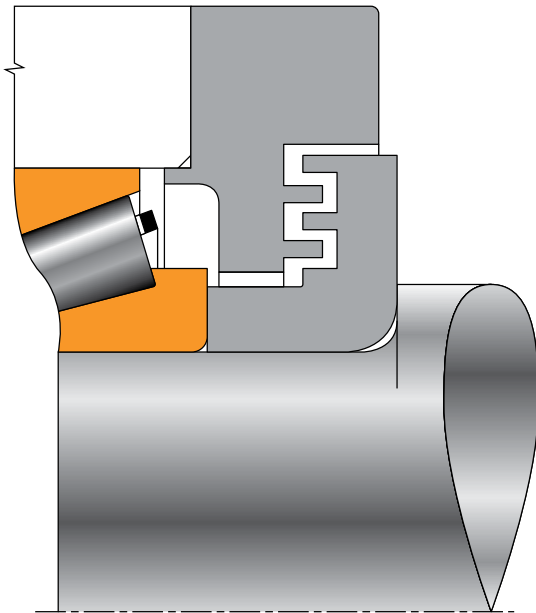

Fig. 162. Labyrinth seal configuration.

SEALING SYSTEMS

ROLL NECKS

Roll neck applications require a robust sealing arrangement at the barrel roll side in both ferrous and non-ferrous mills. This is especially important during wet rolling, where the rolling solution flows directly over the backing (fillet) ring, and for bearings installed in a highly contaminated mill environment. Various sealing designs can be used. For more information on seal designs not shown here, contact your Timken engineer.

The sealing design depends on the available space between the bearing and the barrel roll face, which also corresponds to the backing ring length. Many arrangements have been used successfully to meet various types of operating conditions. Most of these have one or two radial seal lips, sometimes in combination with a face seal or labyrinth for additional protection.

Orientation of the seal lips differs depending on the lubrication system used. In oil-lubricated systems, the seal configuration usually appears as shown in fig. 163. In grease systems, both lips are usually orientated away from the bearing.

Where a pair of radial seal lips is used as a unit in an oil lubricated system, a separate lubricant entry between the two seals is required to prevent lips from rotating on a dry seat. The illustrated arrangement (fig. 163) could vary slightly depending on the available space. The backing rings are generally mounted tight on the roll necks to prevent the entry of the rolling solution through the backing ring bore.

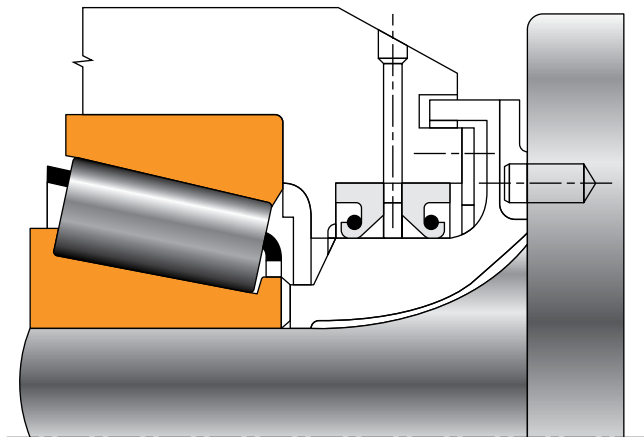

Fig. 163. Two radial seal-lip configuration.

To have the seals remain with the chock and the bearing assembly, use extended cones (TQOWE). This design permits the chock and bearing to become a sealed-unit system. This also eliminates the usual problem of handling damage and rolled-over seal lips as the seals are kept on their seats during roll change.

In addition to the extended ribs, you need a smaller backing ring to obtain a correct sealing arrangement. On the retaining ring side, whatever the retaining device, use one or possibly two radial seal lips.

The sealed bearing concept (fig. 164), which is completely interchangeable with the Timken unsealed (open) bearing, helps to decrease grease consumption and extend bearing life. An additional seal fitted into the bearing will offer additional bearing protection, but it is still important to keep the chock's external sealing arrangement well maintained.

You can receive sealed bearings with solid-cup spacers if they don't need regreased during operation. See page 39 for more details on sealed roll neck bearing solutions.

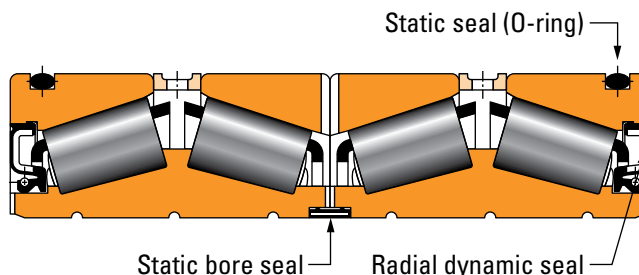

Fig. 164. Integrated sealed work roll bearing concept.

AUXILIARY EQUIPMENT

Auxiliary equipment, such as coilers, uncoilers, pinion stands and reducers, are not exposed to highly contaminated environments. In this case, simpler sealing arrangements are possible. Many types and styles of radial seal lips are commercially available to meet different sealing requirements.

In cleaner environments, where the primary requirement is the retention of lubricant in the bearing housing, a single seal lip with the lip pointing inward often is used (fig. 165).

In contaminated environments, the lip is usually pointed outward. In even more critical environments, a double seal lip or possibly two seal lips are used. An additional labyrinth should be used as primary sealing where extremely dirty conditions are present so that the seal lip and sealing surface stay protected from wear and premature lip-seal damage.

In the case of grease lubrication and a clean environment, you can use metal stamping closures (fig. 166). In dirty environmental conditions, these stampings are used in combination with other closure elements to provide an effective labyrinth against the entry of contaminant. For more efficient grease retention and foreign-matter exclusion, use machined flingers with an annular groove closure provided on the stationary part (fig. 167).

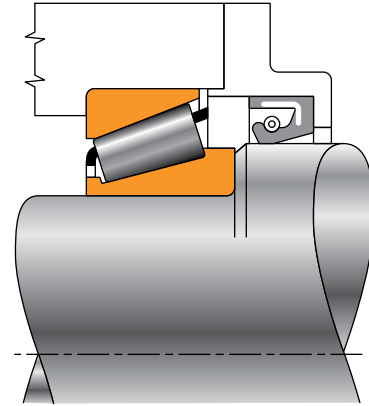

Fig. 165. Single seal lip.

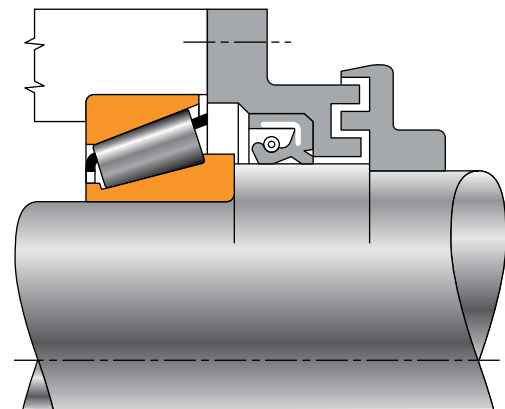

Fig. 166. Single seal lip plus labyrinth.

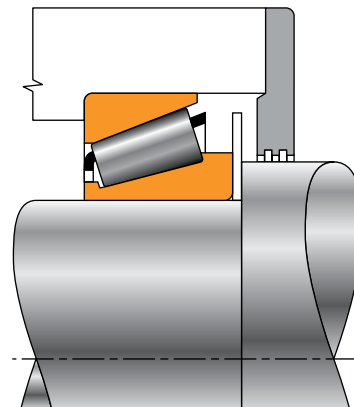
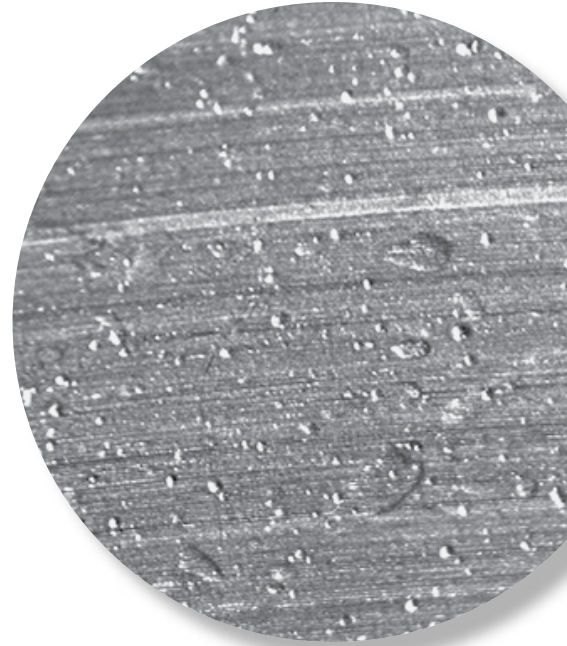

Fig. 167. Machined flinger combined with annular groove closure.

APPLICATION CHALLENGES AND ENHANCED BEARING SOLUTIONS

This section contains information on the following topics:

- High-performance bearings.
- Contact fatigue.
- Debris.
- Lubrication.
- Corrosion.
- Precision rolling.
- High acceleration.



HIGH-PERFORMANCE BEARINGS

Metals applications include ladle furnaces (basic oxygen furnace [BOD]/argon oxygen decarburization [AOD]), casters, rolling mill stands and auxiliary equipment such as gear drives, coilers and shears. These demanding applications operate in tough environments. Potential challenges include heavy loads, shock loads, high speeds, acceleration, high temperatures, debris contamination and corrosion that can adversely affect the performance of standard bearings, prohibiting them from reaching their full life potential.



Fig. 168. Engineered surface high-performance bearing.

Timken enhanced-bearing solutions help reduce overall equipment-design and operation costs. To increase bearing life and reliability, we offer high-performance bearing solutions that apply proprietary technology in materials, design, surface finishing, profiled contact geometry and coatings. These include DuraSpexx[®], debris resistant bearings, engineered surfaces (fig. 168), and corrosion resistant bearings. Each bearing solution is designed to enhance

performance for a specific set of primary damage modes. In various environments, typical service life improvements from one and one-half times to six times have been demonstrated. Performance varies depending on applications and operating environments.

Targeting the most demanding environments, our high-performance bearings are designed to provide:

- Higher-value finished product.
- Increased bearing performance and longer life.
- Increased power density with more power throughput capacity in the same bearing envelope size.
- Reduced equipment maintenance and servicing costs.
- Increased equipment uptime and productivity.

You can implement high-performance bearings at any stage, from prototype to end use, without requiring a system redesign. Through sophisticated, application-focused analytical tools, our engineers suggest the ideal product for your operating environment.

Our high-performance bearing technology aims to improve bearing service life by minimizing most of the primary damage modes caused by contact fatigue and overloading, marginal lubrication, corrosion and debris denting/contamination.

CONTACT FATIGUE

CONTACT FATIGUE CHALLENGES

Fatigue damage is the normal result of rolling contact, stress and environmental conditions.

Any bearing, under given operating conditions, possesses a statistically calculated life expectancy based on laboratory testing and field experience. Refer to the Bearing Life Calculations and Related Analysis section on pages 67-93 for details on bearing life calculations.

Spalling is the pitting or flaking away of bearing material on the races and the rolling elements.

There are many types of primary bearing damage that will eventually deteriorate into a secondary damage mode of spalling. We classify three distinct types of spalling damage.

INCLUSION ORIGIN SPALLING

Inclusion origin spalling (fig. 169) results from material fatigue at localized areas of the sub-surface following millions of alternate loading cycles accelerated by the presence of non-metallic inclusions in the steel. The damage appears in the form of localized, elliptically shaped spalls.



Fig. 169. Inclusion origin spalling.

POINT SURFACE ORIGIN (PSO) SPALLING

Point surface origin (PSO [fig. 170]) spalling is the result of very high and localized contact pressure causing the bearing to prematurely fatigue. The spalling damage is typically caused by the combination of boundary lubrication/thin-film operating conditions with high stress at the microasperity contact points from fatigue spalling, nicks, dents, debris, etching or hard particle contamination. PSO spalling is the most common spalling damage and often propagates as an arrowhead-shaped spall due to oil film hydraulic pressure that raises the metal and peels the surface.



Fig. 170. Point surface origin spalling (PSO).

GEOMETRIC STRESS CONCENTRATION (GSC) SPALLING

Geometric stress concentration (GSC) spalling (fig. 171) is the result of misalignment, deflection or edge loading that initiates high stress at localized regions of the bearing. The damage occurs at the extreme edges of the race/roller paths and is usually caused by problems with the shaft, housing or high loads.



Fig. 171. Geometric stress concentration spalling.

CONTACT FATIGUE SOLUTIONS

In most cases, one or more enhancements alleviate contact fatigue challenges and help maximize bearing life.

CLEANER STEEL

If the damage is material-related, improved steel cleanliness may maximize bearing fatigue life. Non-metallic inclusions in bearing steel serve as stress risers. The fewer and smaller the inclusions, the less chance there is of one of these inclusions being in the stressed volume below the surface. Consider super-clean bearing steel for highly loaded applications. This type of steel also can be combined with enhanced surface finishes and bearing profiles to help maximize performance.

Fig. 172 shows that the use of our super-clean steel can result in up to two times improvement in bearing life.

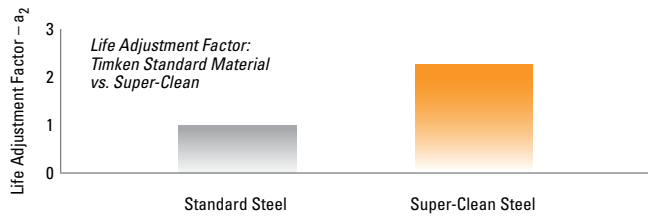

Fig. 172. Clean steel effect on bearing life.

Our super-clean steel provides the benefit of extending bearing fatigue life when limited by non-metallic inclusions (inclusion origin spalling of the raceway).

Situations where super-clean steel provides the most benefits include:

- Mill revamps with increased bending forces and existing bearing envelopes are fixed.
- Gear drives, where increased horsepower can be accommodated by using cleaner steel.
- Applications that demand compact equipment design.

If the primary failure mode is not related to inclusion origin spalling, the benefits of using super-clean steel may not be realized, such as in the following situations:

- High-misalignment/high-edge stresses.
- Low lubricant-film/asperity contact.
- Heavy debris contamination environments.

SPECIAL PROFILING

We routinely apply a profile to our bearing components to minimize the edge stress that can occur at either the large or small end of the roller. These standard profiles help accommodate normal loads.

In certain application conditions, experiencing extremely high loads or misalignment, you may need a special roller profile to distribute the stress across the raceway more evenly. The geometric stress concentration at the end of the roller contact must be reduced significantly to minimize the potential for spalls at the edge of the roller path (geometric stress concentration [GSC] spalling).

Figs. 173 – 175 show the pronounced effect of adding special profiling to a tapered roller bearing. This stress profile analysis makes up one component of the Timken Syber Application Analysis program.

PROFILE ENHANCEMENT EFFECT ON BEARING LIFE

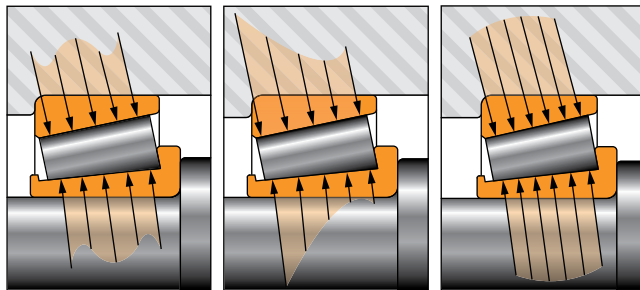

Fig. 173. Roller-race stress distribution under high load – standard profile.

Fig. 174. Roller-race stress distribution with misalignment present – standard profile.

Fig. 175. Roller-race stress distribution with special profiling to minimize effect of edge loading.

Our enhanced profile technology can result in an improvement of up to four times bearing life by providing more evenly distributed stress (fig. 176) under high loads or misalignment.

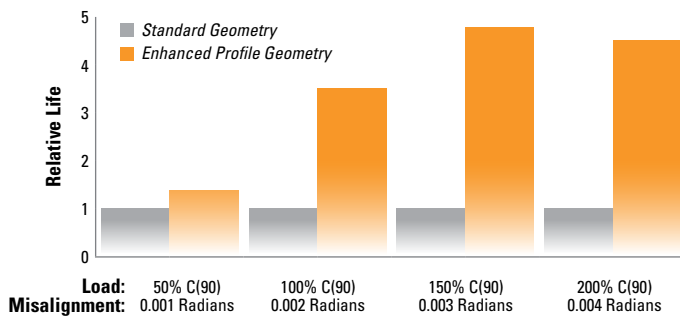

Fig. 176. Profile enhancement effect on bearing life.

TIMKEN® DURASPEXX® BEARINGS

Timken® DuraSpexx® bearings (fig. 177) feature special finishes on the rollers, cone and cup races to help reduce surface-related modes of damage point surface origin (PSO) and advanced geometry profiles to minimize edge stress concentrations caused by high loads or misalignment. Coupled with enhanced materials to reduce inclusion-related damage, these bearings can provide a relative life up to four times higher than our standard bearings.



Fig. 177. DuraSpexx® bearings.

DEBRIS

DEBRIS CHALLENGES

Debris commonly causes premature bearing damage, particularly in harsh rolling mill environments. Contaminants such as grit, dirt, heat-treat scale and metallic wear particles from gears, splines and failed or spalled components that come in contact with bearing roller and raceway surfaces can create dents (fig. 178). The damage that results from debris significantly deteriorates bearings, reduces fatigue life and ultimately causes bearing damage.

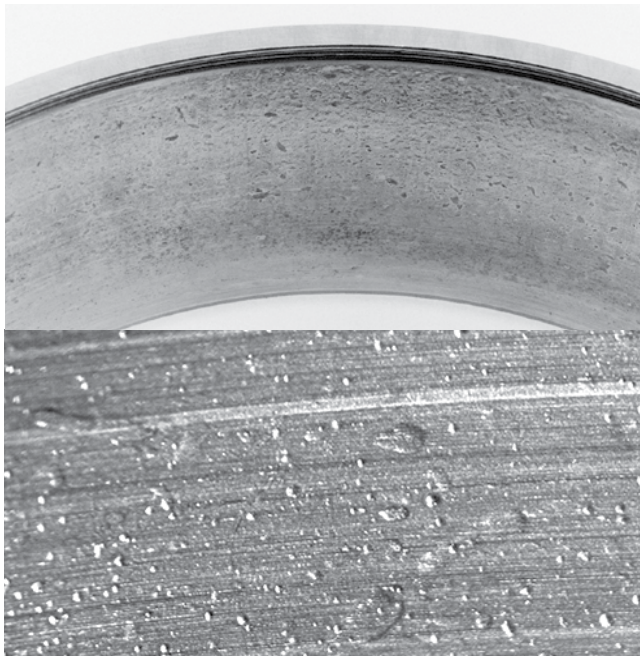

Fig. 178. Debris damage on bearing raceways.

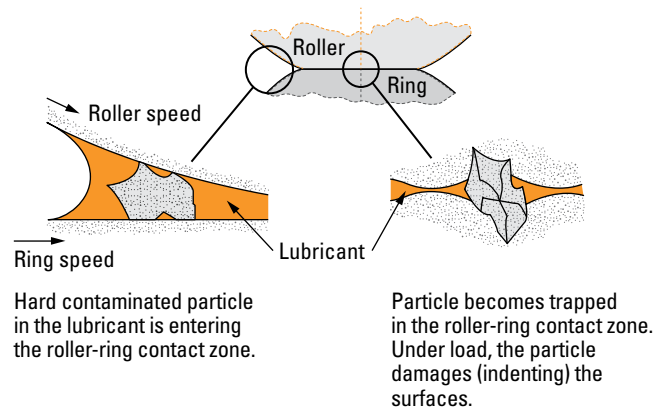

Fig. 179. Graphical representation of dent formation.

Large particles travel through the bearing within the lubrication and bruise the contacting surfaces.

The dents form shoulders – some severe – that act as surface-stress risers, causing premature surface damage and reducing bearing life (fig. 179). Metallic debris particles can cause the most severe bearing damage for a given particle size and concentration.

In many cases, our standard case-carburized bearings provide superior performance by minimizing the impact of debris in a given system. In fact, in controlled laboratory tests under identical debris conditions, our standard bearings consistently equaled or out-performed bearings from several major competitors.

In cases where significant debris problems exist, we offer an advanced level of protection and performance – the Timken® debris-resistant bearing. It is available in a wide variety of sizes and bearing types.

DEBRIS SOLUTIONS

DEBRIS-RESISTANT BEARINGS

We created our debris-resistant bearings using a combination of proprietary alloy and heat-treatment modifications and hard-film coating technology to optimize their mechanical properties. Our debris-resistance technology interrupts adhesive wear and self-repairs microcracking, which can provide you with extended life performance.

Debris-resistant bearings show increased performance up to three times that of standard Timken bearings in a debris environment under low-lubrication conditions (fig. 180).

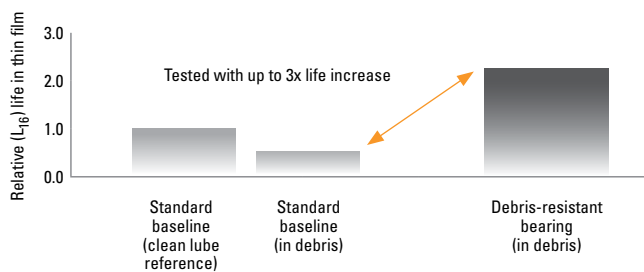

Fig. 180. Fatigue test results – moderate debris.

To help determine whether our debris-resistant bearings are appropriate for your operating systems, our engineers have developed computer-based analysis tools that allow them to model the severity of your operations debris by reviewing dents and other debris damage on a bearing’s raceway surface (fig. 181). Conclusions from damage inspections provide more data from which to choose the most appropriate debris solution.

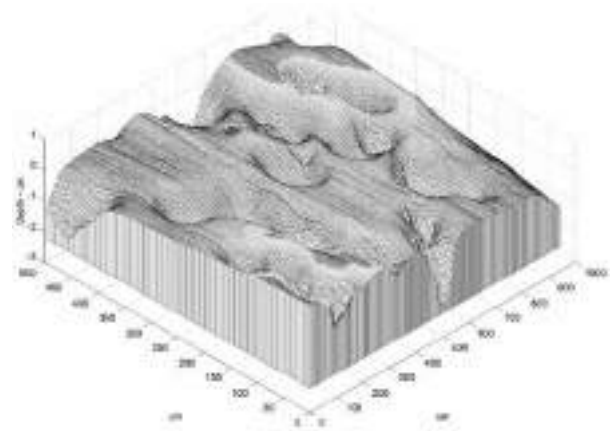

Fig. 181. Field of indentation sites generated in our debris signature analysis program.

Our debris-resistant bearings typically come in tapered, spherical and cylindrical bearing designs starting at 200 mm (7.874 in.) outside diameter. Our debris-resistant bearings fit into your application’s existing envelope size to help you avoid costly redesigns. In addition, advanced manufacturing processes allow us to offer them economically in both large and small quantities.

With our debris-resistant bearings, you can experience increased bearing life and productivity without system redesign.

LUBRICATION

LUBRICATION CHALLENGES

Inadequate lubrication creates a wide range of damage conditions. Damage happens when the lubricant intended for a bearing is not sufficient enough to separate the rolling and sliding contact surfaces during service or when insufficient lubrication is supplied.

Tapered roller bearings also can experience another damage mode that often is attributed to marginal lubrication called roller-end scoring (fig. 182). While scoring damage may be attributed to excessive preload or excess heat generation at the rib contact, it is most frequently associated with the thin-film lubrication layer separating the roller-end and rib contact.

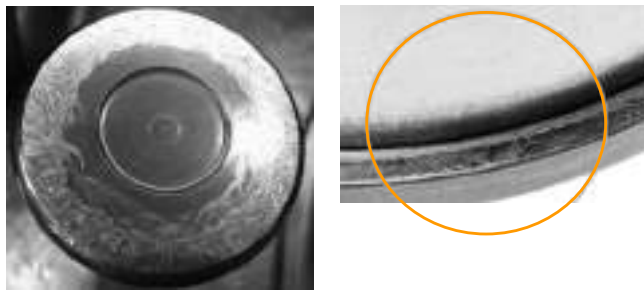

Fig. 182. Typical rib-roller end scoring on a tapered roller bearing.

It is very important that the proper lubricant amount, type, grade, supply system, viscosity and additives be defined for each bearing system. The right selection is based upon history, loading, speeds, sealing systems, service conditions and expected life. Without proper consideration for these factors, less than adequate bearing and application performance may be expected.

The damage caused by inadequate lubrication varies greatly in both appearance and progression. Depending on the level of damage, it may range from very light roller end or rib discoloration (fig. 183) to total bearing seizure.



Fig. 183. Roller end and rib discoloration.

LUBRICATION SOLUTIONS

SURFACE FINISH ENHANCEMENT

Lubrication and lubrication film thickness are critical factors in maintaining proper bearing performance. Film thickness, combined with the composite surface roughness of the roller and raceway in contact determine the lambda (λ) ratio (fig. 144 on page 98). If the lambda ratio is too small (less than 0.8), then asperity contact may occur, which will potentially lead to roller and race peeling damage (fig. 184) or PSO spalling.



Fig. 184. Roller peeling damage.

Our enhanced-finishing technology can generate up to four times improvement in bearing life by smoothing and reducing the height of surface contact asperities (fig. 185).

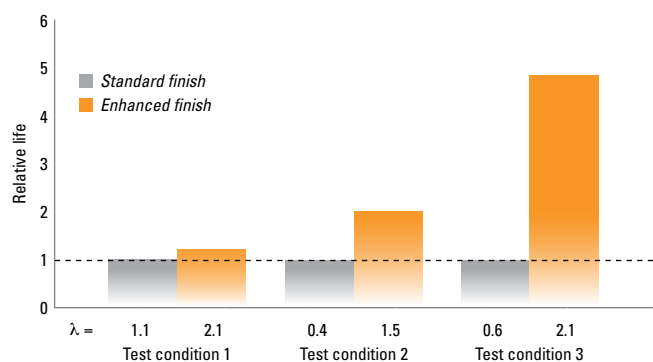

Where:

$$\lambda = \frac{\text{Film thickness}}{\text{Composite roughness of two surfaces}}$$

Fig. 185. Surface-finish enhancement impact on bearing life.

TIMKEN ENGINEERED SURFACES

We create engineered surfaces (ES) through both topographical modification (changing the surface finish) and special coatings.

Topographical modifications include our ES10 and ES20 processes. These finishing methods reduce the surface roughness to levels much lower than with conventional approaches. The smoother, topographically modified surface (figs. 186 and 187) have fewer prominent asperities (microscopic high spots) that can interact with the surfaces of mating components as they come into contact, helping to reduce friction and wear.

The engineered surfaces created through coatings (ES200 and ES300 series) feature a thin film, nano-composite, metal-carbide matrix having a thickness of 1 to 3 μm (40 to 120 $\mu\text{in.}$) that provides extremely hard and low-friction surface properties.

We apply the coatings (fig. 188) using a physical vapor deposition process, creating a surface up to two times harder, yet more elastic, than steel. The coatings have a friction coefficient that is less than 50 percent that of steel in sliding experiments.

We apply our coatings at temperatures that do not affect the hardness of the substrate material (less than 160° C [320° F]).

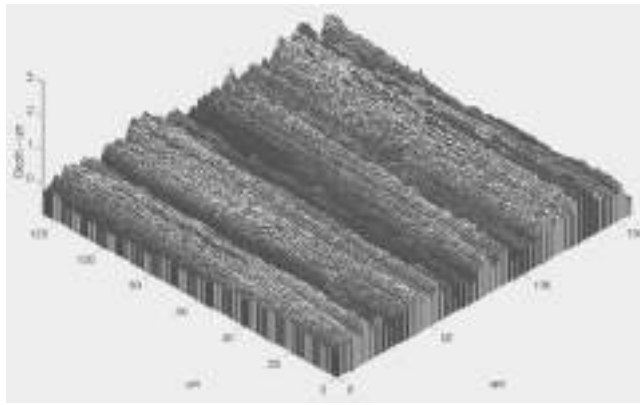

Fig. 186. Ground finish surface topography.

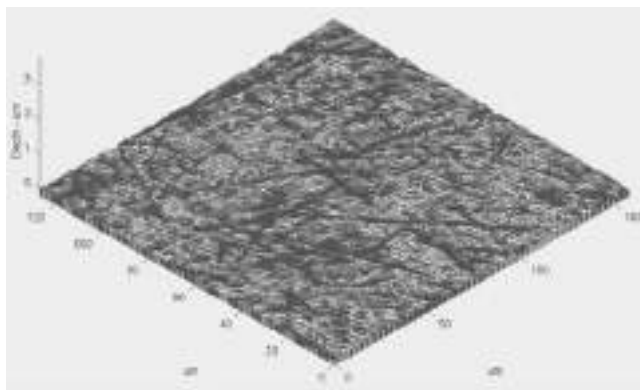

Fig. 187. ES20 finish surface topography.



Fig. 188. Coated bearings.

Bearings featuring our engineered surfaces are commonly used where optimal bearing performance and uptime are critical.

The combination ceramic- and polymer-like properties of our ES coatings inhibit microwelding and adhesive wear at the roller and race interfaces, significantly minimizing metal-to-metal contact.

ES coatings can provide debris resistance, reduced friction and torque at sliding or poorly-lubricated interfaces, reduced component scuffing and smearing damage, increased life in thin-film lubrication, decreased false brinelling wear and oil-out protection.

We've tested and optimized ES coating formula for maximum performance in challenging applications. Test data for bearings featuring engineered surfaces verifies bearing life improvements up to nine times over standard designs.

APPROPRIATE ENGINEERED SURFACE SELECTION

The selection of the appropriate engineered surface finish or coating requires an evaluation of the application tribological conditions. While greatly simplified, table 9 demonstrates how we consider the lubrication effectiveness (λ) and contact mode to select the proper type of finish or coating for an application.

TABLE 9. SELECTING THE PROPER ENGINEERED SURFACE FINISH OR COATING

Tribological Condition Damage Mode	Solution to Concern	Mechanism
Low λ (thin film) reduced fatigue life due to poor or thin film lubrication conditions	ES302 coating on roller	Hard coated surface acts as dissimilar material to reduce adhesive wear and polish uncoated mating surfaces increasing effective λ ratio
Scoring damage from loss of lubrication	ES200 or ES300 coatings on roller ends (sliding surfaces)	Coating forms a barrier to adhesive wear and reduces friction
Reduced fatigue life due to debris	ES300 or ES302 coating on roller	Hard coated surface acts as dissimilar material to reduce adhesive wear and reduce shoulders height around debris dents on uncoated raceways
False brinelling, fretting, scuffing and smearing	ES300 or ES302 coating on roller	Coating forms a barrier to the adhesive wear mechanism on raceways

CORROSION

CORROSION CHALLENGES

A leading cause of antifriction bearing damage in roll neck applications is water-based corrosion damage.

Water ingress causes line corrosion to occur at contacts between raceways and roller bodies. Although water rarely presents a problem while bearings are in operation, a loss of lubricant film when the bearings remain stationary leaves little to no protection. Water that penetrates defective or damaged seals, or condensation that forms inside the chock due to temperature changes, drains to the bottom of the chock and comes into contact with the rollers and raceway surfaces. This causes corrosion, starting in the form of black oxide, that is called staining (fig. 189). Most of the time, you can remove staining with a fine abrasive material and re-use the bearing. With longer exposure to moisture, this corrosion will cause pitting of the bearing material (fig. 190), which eventually leads to more severe damage called etching (fig. 191). At this stage, the bearing must be either discarded or refurbished, depending on the depth of the damage.

Poor storage conditions, together with improper washing and drying when they are removed for inspection, also can cause considerable damage (fig. 192).



Fig. 189. Staining without pitting.



Fig. 190. Pitting on roller.



Fig. 191. Deep etching on an outer ring race.



Fig. 192. Damage caused by poor storage conditions.

After cleaning and drying, you should coat bearings with oil or another preservative and wrap them in a protective paper (fig. 193) before putting them into storage. Always store new or used bearings in a dry area and in appropriate packaging (fig. 194) to reduce risk of corrosion appearing before mounting.



Fig. 193. Oil protection and special protective paper.



Fig. 194. Vacuumed and hot-sealed aluminum foil bags for large bearings.

CORROSION SOLUTIONS

TIMKEN® AQUASPEXX® BEARINGS

Timken® AquaSpexx® bearings (fig. 195) combat bearing damage caused by water ingress and water-based corrosion by using a proprietary, electrically bonded, zinc-alloy coating that protects raceways and other functional surfaces.

This process provides an iridescent appearance, which may vary from piece to piece. The corrosion protection provided by the coating is classified as galvanic and applied directly to finished components.



AquaSpexx® cup after testing Uncoated cup after testing

Fig. 195. Comparison of AquaSpexx® and standard bearings after testing in a corrosive application.

TIMKEN THIN-DENSE-CHROME BEARINGS

Thin-Dense-Chrome (TDC) bearings feature a proprietary thin, hard, chrome-based, barrier coating that provides superior corrosion resistance and superior performance in wet or corrosive environments. These bearings resist corrosion by three to nine times that of traditional bearings.

TDC bearings specifically provide increased performance in harsh corrosion environments. This includes some acidic and basic solutions where standard, unprotected bearings will experience premature damage.

PRECISION ROLLING

HIGHER BEARING PRECISION FOR OPTIMIZED GAGE ACCURACY

Roll neck bearing precision directly impacts the quality of rolled product. In cold rolling operations, runout in the backup roll bearings can be transferred to the product being rolled and appears as longitudinal variations in product thickness. Precision bearings offer reduced runout and can improve the thickness control capability of the rolling mill.

The accuracy of four-row cylindrical roller bearings in backup roll positions is typically enhanced by finish grinding the inner rings after mounting on the roll neck. Inner rings are mounted on the roll neck and their races are ground to minimize any eccentricity of the inner ring outside diameter (O.D.) with respect to the backup roll body.

The accuracy of standard four-row tapered roller bearings in backup roll positions can be further enhanced by specifying higher precision tolerances that provide an improved level of accuracy.

Our manufacturing capabilities allow us to hold the inner ring wall section variation to very tight tolerances.

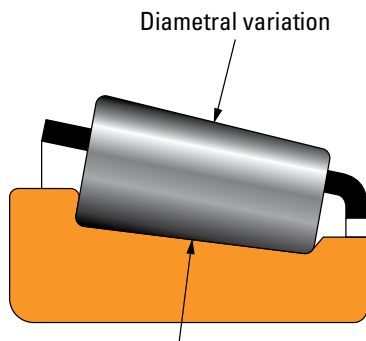

Fig. 196. Roller size variation (tapered roller bearing example).

Bearing runout, which is comprised of repeatable runout (wall section variation) and non-repeatable runout, or roller size variation and roller-end roundness.

It is important to control wall section and roller size variation (fig. 196) because any high spots in individual bearing components will result in radial movement or runout of the bearing.

Bearing runout, which is comprised of repeatable runout (wall section variation) and non-repeatable runout, or roller size variation and roller-end roundness.

Cone wall thickness variation will appear as repeating runout (synchronous [fig. 197]) while roller size variations will cause non-repeatable (asynchronous [fig. 198]) variations.

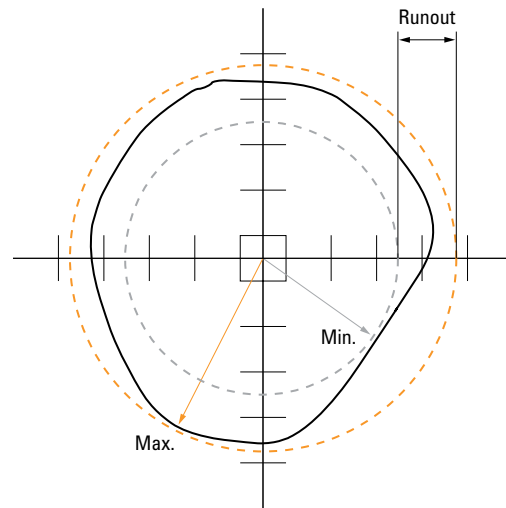

Fig. 197. Repeatable runout (synchronous).

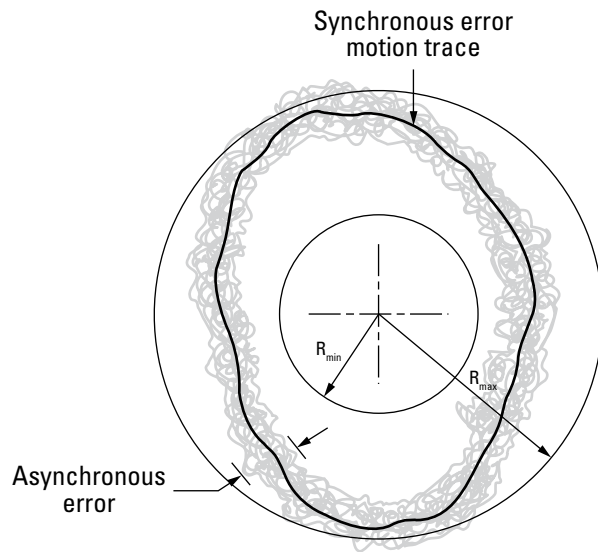

Fig. 198. Non-repeatable runout (asynchronous).

HIGH ACCELERATION

Cages, also called retainers, perform an important function in the proper operation of roller bearings. They maintain uniform rolling-element spacing as the rolling-elements pass into and out of the load zone. Demanding dynamic working conditions, like high accelerations or decelerations, vibrations or shocks with high amplitude and frequency, as well as high bearing operating clearance, all influence the cage behavior.

CAGE CHALLENGES

Under the demanding dynamic working conditions described above, the rollers will accelerate or decelerate at a high rate. The resultant impact of the rollers against the cage bridges, fingers or pins, depending on the cage type, creates a dynamic bending cycle (fig. 199) that may generate fatigue cracks that will damage the cage. We developed several cage types and materials to meet various service requirements.

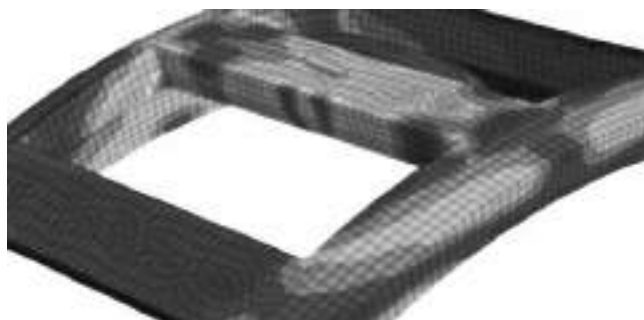

Fig. 199. Example of stamped-steel cage and roller interaction due to one roller accelerating and impacting the cage bridge (maximum stress shown with dark grey in the stress distribution picture).

CAGE SOLUTIONS

We developed a proprietary calculation tool called CageDyn to study the performance of cages in dynamic conditions. CageDyn performs fast and precise calculations to identify the damage risks and assess the influence of cage design and material selection.

For challenging applications subjected to high loads, vibration, speeds or accelerations, special cages may be required to minimize damage occurrence. Potential solutions include:

- Material change.
- Enhanced design to minimize stresses.
- Reduced cage window – roller clearance.
- Wider cage bridges or finger width.
- Increased cage material stock.
- Optimized bearing internal clearance.

Using CageDyn to simulate the performance of bearing cages in difficult application conditions is useful in minimizing the amount of prototyping and testing for a new design, saving time and cost. Detailed studies can be done quickly, improving accuracy and reducing product lead time. CageDyn also can analyze bearing applications to ensure that the correct type of cage is specified and reduce the chance of cage problems in service.

For a detailed analysis of bearing cage performance behavior in your application, please contact your Timken engineer.

RELATED PRODUCTS

This section contains information on:

- Seals and lubricant.
- Maintenance tools.
- Condition monitoring equipment.
- Timken® housed units.
- Timken® Quick-Flex® couplings.
- Precision chain products.



SEALS AND LUBRICANT

In addition to our line of bearings, we also offer a wide range of related products tailored to the metals industry. This section includes information about seals, lubrication, maintenance tools, condition monitoring equipment, housed units products.

SEALS AND LUBRICANT

SEALS

Our line of industrial seals includes a variety of different material options to suit almost any industrial application. Our seals are ideal for tough applications and provide resistance to extreme temperatures, pressure, debris and most chemicals. They also provide excellent sealing capability in thick, viscous fluids, higher tensile strength and lower cold flow and creep than PTFE (PolyTetraFluoroEthylene) materials.

Timken offers a range of seal solutions, including:

Oil and grease seals – These seals prevent abrasives, corrosive moisture and other harmful contaminants from entering the mechanics of machines in a variety of environments.

V-Seals™ – Made of Nitrile or Viton®, these highly elastic seals ease installation, fit a broader range of shaft sizes and can be used on eccentric and misaligned shafts.

Redi-Seals® service – Through this innovative program, customers can receive high-quality sealing devices within 24 hours of order.

Redi-Sleeve™ technology – These steel wear sleeves, designed to be pressed onto a shaft, provide an option to quickly repair damaged, grooved or worn shafts.

Shaft repair kits – These kits are alternatives to shaft replacements.

Redi-Coat® – This patented sealant fills nicks and scratches in poorly finished bores.

Our industrial seals are available in small-bore sizes, up to 13 inches or 325 mm, as well as in metric and high-temperature varieties. We also provide tools to speed installation, deter seal and bearing damage and prevent premature seal leakage. The seals and tools can be applied in a full range of equipment used in thousands of applications, including manufacturing, off-highway, power transmission and oil refineries.

Timken oil seals are offered in a variety of choices to fit your individual application and operating specifications. In addition, they are color coded for easy identification (fig. 200).

- Timken Nitrile (N), Black Industrial Seals – Recommended for applications with a continuous operating temperature of approximately 200° F. Peak temperature is 250° F.

- Timken Hydrogenated Nitrile Butadiene Rubber (HNBR) Blue Industrial Seals – Recommended for applications with a continuous operating temperature of approximately 300° F. Peak temperature is 350° F.
- Timken Fluoroelastomer (V) Green Industrial Seals – Recommended for applications with a continuous operating temperature of approximately 400° F. Peak temperature is 450° F.

Timken Nitrile (N)
(Black seals)

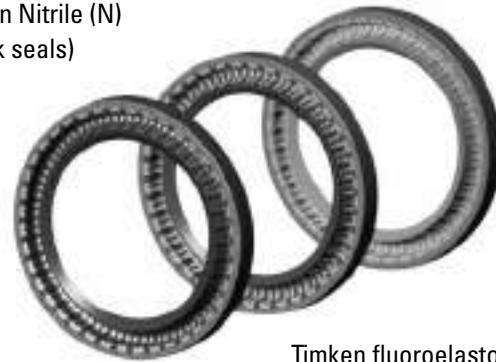

Timken hydrogenated nitrile
Butadiene rubber (HNBR)
(Blue seals)

Timken fluoroelastomer (V)
(Green seals)

Fig. 200. Timken high-performance seals.

LUBRICANTS

Around the world, customers use our lubricants for rolling mills, rail bearings, power generation equipment, construction and transportation vehicles, and other industrial applications. Specially developed for steel mill applications, Timken Mill Grease improves water washout resistance, protection against rust and corrosion, high-temperature performance and oxidation stability.

The Timken line of application- and environment-specific lubricants was developed by leveraging our knowledge of tribology and anti-friction bearings and how these two elements affect overall system performance. Timken lubricants help bearings and related components operate effectively in demanding industrial operations. High temperature, anti-wear and water-resistant additives offer superior protection in challenging environments.

The seven primary lines of Timken lubricants compliment our G-Power and M-Power single-point lubricators, C-Power centralized multi-point lubricators and our global offering of lubrication products. G-Power, M-Power and C-Power units consistently distribute grease into machine operations. These canisters can be filled with Timken lubricants or many other types of commercial lubricants and mounted into place with a full line of Timken accessories.

MAINTENANCE TOOLS

HYDRAULIC PULLERS

We offer a wide range of self-contained portable hydraulic pulling systems that have capacities from 4 to 30 tons. They are ideal for removing all kinds of shaft-fitted parts. Our practical self-centering hydraulic pullers convert easily to either a two- or three-arm puller (fig. 201). The compact design is ideal for pulling a wide variety of press-fit parts including bearings, wheels, bushings, gears and pulleys. The pump handle rotates 360 degrees, providing flexibility to use the puller in the most convenient position.



Fig. 201. Hydraulic three-arm puller.

INDUCTION HEATERS

Use our yoke-type induction heaters (fig. 202) in demanding industrial applications. They can rapidly heat and radially expand a wide variety of gears, rings, couplings, bearings and other components. We produce all heaters in accordance with international (IEC) and European (CE) health and safety requirements. They feature a microprocessor-controlled power supply, built-in time and temperature control, and automatic demagnetization.



Fig. 202. Timken yoke-type induction heaters.

TIMKEN® ECOPOWER™ INDUCTION HEATER

Use the new Timken® EcoPower™ Induction Heater (fig. 203) to mount and dismount tight-fitted components. The flexible design eliminates the need for the yoke.

This new heater type consists of a generator and a selected induction tool. The latter is a Fixed-Coil type – specified for certain given dimensions – or a Flex-Coil type – like a cable wrapped around the outside or inside of the work piece. This tool gives the opportunity to adapt a magnetic field onto a workplace surface of many different sizes and shapes. It also is possible to connect a heating table to the generator.

You can achieve significant time savings due to the high efficiency of the generator/coil system that brings up to 90 percent of the input power directly to the workpiece. The main contributing factor is the induction coil (fixed or flexible coil) that is placed directly on the surface that needs to be heated.



Fig. 203. Timken® EcoPower™ induction heater.



Fig. 204. Example of a 1300 kg (2900 lb.) gear wheel wrapped with two flex coils.

You only need a total of 23 minutes from flex coil installation to shaft dismounting of a 1300 kg gear in the above example (fig. 204).

CHOCKLOK™

The Chocklok™ (fig. 205) locking ring assembly retains a chock/bearing assembly on a roll. It replaces the heavy OE split ring and adjusting nut to simplify chocking/dechocking. This easy-to-use system has only six bolts to tighten, can be mounted on most mill designs and typically reduces the chock installation and dismounting time by half.



Fig. 205. Timken ChockLok™.

ROLL NECK HANDLING TOOLS

Handle roll neck bearings safely and carefully when mounting them into or removing them from the chock to avoid any damage to the critical surfaces. You can use a variety of tools depending on bearing type, size, weight, cage type and if bearing parts are assembled separately or as a unit (i.e., sealed bearings).

For example, in the case of large bore four-row tapered bearings with pin-type cages, single and double cones can be lifted by using eye-bolts mounted in the threaded holes provided in the cage rings.

Bearings with stamped-steel cages use special lifting fixtures.

We offer two basic styles of lifting fixture:

- Three-legged (fig. 206).
- Sliding-foot (fig. 207).

Often, operators use their own tools. But if you do so, take care not to damage the bearing components.



Fig. 206. Three-legged fixture.

Fig. 207. Sliding-foot.

We deliver most sealed tapered roller bearings pregreased. Handle and mount it into the chock as an assembled unit. You can also use this solution to mount a standard, non-greased two- or four-row assembly as an unit.

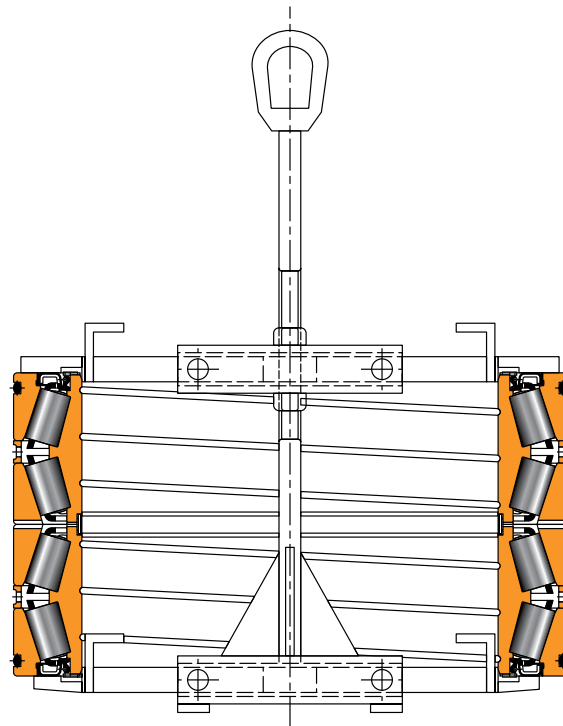

Fig. 208. Sealed roll neck bearing and lifting fixture.

Fig. 208 (previous page) shows how the sliding foot lifting fixture clamps to the bearing at both ends to lift the entire sealed bearing assembly into and out of the chock. Accessing through the cone bore, the fixture supports the bearing at the bottom and clamps through the top cups. It supports the bottom of the bearing at the cup to lift the entire bearing. Chock designs should allow clearance for lifting-foot access to the cup end faces for proper lifting support of the complete bearing assembly.

CONDITION MONITORING EQUIPMENT

In the metals industry, you aim to maximize uptime, safety and profitability. You must avoid any unscheduled downtime. You should identify any unsafe condition and repairs must be made immediately. We have a broad offering of condition monitoring products and services that include portable instruments, continuous monitoring devices and online systems. We can help you maximize uptime by developing cost-effective solutions that achieve maximum output and reliable service. Increasing the useful life and productivity of your machinery directly impacts the bottom line.

Our handheld Bearing Tester is portable and pocket-sized as well as reliable, affordable and easy to use. The bearing tester offers users the flexibility to perform periodic machine condition checks, helping avoid production losses from unplanned downtime and reducing overall maintenance costs. Its compact and lightweight design makes the bearing tester a convenient tool for assessing the health and lubrication condition of ball and roller bearings in many industrial environments.

STATUSCHECK™ WIRELESS CONDITION MONITORING SYSTEM

The StatusCheck™ system is a unique wireless system that detects and monitors excessive levels of temperature and vibration. It provides a cost-effective method to report changes in temperature and vibration in real time, giving you an opportunity to correct a potential problem before it becomes critical. It ultimately helps prevent damage, expensive repairs and prolonged downtime.

DESIGN ATTRIBUTES

- Wireless configuration.
- Dual mounting (magnetic or threaded).
- Contact temperature probe.
- Two-axis vibration detection.
- Acceleration and velocity measurement.
- Multiple connectivity options.



TIMKEN ONLINE INTELLIGENCE SYSTEM

The Online Intelligence System continuous monitoring platform takes sophisticated, reliable readings from the most rugged and challenging operating environments. It then compiles that data into manageable, easy-to-use information for decision making that improves reliability and profitability. The Online Intelligence System helps reduce inconsistencies in data to ensure that potential problems are not missed.



The Online Intelligence System allows you to adjust measurement parameters to meet current conditions and still handle fluctuations with precision. Then, when it detects a problem, our service engineers analyze the data, conduct additional testing and suggest a solution to enhance your equipment availability.

TIMKEN® HOUSED UNITS

SPLIT-BLOCK PLUMMER (PILLOW) BLOCKS

Timken offers a broad range of SNT metric plummer block and SAF inch pillow block line which includes a wide range of sizes, housing designs, seals and accessories developed to meet your specific requirements. Constructed of cast iron, the standard line of Timken split-block housings is designed to protect bearings. For more rugged applications, choose housings made from ductile iron or cast steel that are up to two times stronger than cast iron.

Inside Timken split-block housings, you'll find high-performance Timken® spherical roller bearings featuring precisely engineered geometry and raceway finishes. Plus, our spherical roller bearings feature a unique design that allows them to run cooler and more efficiently on misaligned shafts up to ± 1.5 degrees without a reduction in life expectancy.

BENEFITS OF TIMKEN SPLIT HOUSINGS

- Standard shaft sizes available ranging from:
 - SNT from 20 mm to 400 mm shaft sizes.
 - SAF from 1 3/8 in. to 19 1/2 in.) shaft sizes.
 - Custom designs available for larger shaft sizes.
- Reduce downtime through fast shipments from inventory on most standard shaft sizes and prompt replacement components through comprehensive inventory levels of housings, bearings, mounting hardware and seals.
- Design options include a tapered bore design for easy mounting or a straight bore design for better axial location. Readily convert the block from fixed to float by removing the stabilizing ring.
- Easy ordering for a full assembly or a few parts through a well-stocked inventory typically enables quick shipment of standard parts and assemblies.

SPECIFIC CONFIGURATIONS

Rugged cast-iron (standard) construction handles tough environments. Ductile iron and cast-steel housings are also available for extremely heavy-duty jobs. Timken® high-performance spherical roller bearings provide reliable, longer service. Numerous bore sizes and configurations help you find what you need. Easy-to-install separate cap and base allow quick bearing inspection and replacement. Advanced sealing and lubrication options suit your specific needs. Mounting flexibility for tapered and straight bores with adapters and stabilizing rings solve challenging installations. Easy conversion from fixed to float reduces inventory needs.

SEAL APPLICATIONS

SNT seal options include double-lip, labyrinth, V-Ring, and taconite

- Double-Lip Seals (TSNG): Most common seals with Timken SNT housings. This seal is made of polyurethane for good wear resistance in challenging environments.
- Labyrinth Seals (LO): The labyrinth non-contact seals have multiple labyrinth stages effective in sealing out contaminants such as dirt and dust and sealing in grease.
- V-Ring Seals (VR): Two-piece seal that excels in applications high speed applications or where shaft roughness is an issue.
- Taconite Seals (TA): Heavy-duty labyrinth seals that are ideal for high contamination areas. They can be re-lubricated to enhance sealing qualities and extend life.

SAF pillow blocks come standard with LER seals, options include Timken Guard (superior protection against contamination), DUSTAC and taconite seals.

- Timken Guard (TG) Seal: Helps prevent lubrication from escaping and contamination from entering. This design reduces frictional heat, exerts little to no torque on the system and leads to longer lives for the bearing and seal.
- DUSTAC® seal: Helps shut out residual and airborne contaminants using a V-shaped nitrile ring that rotates with the shaft and applies pressure to the cartridge face.
- RLS series: Forms a wedge-shaped cavity around the shaft and labyrinth that is filled with heavy grease.
- SRLS series: Features an O-ring in the bore as part of a split face labyrinth seal. Designed to prevent contaminant ingress and axial displacement.

Split plummer (pillow) blocks handle demanding heavy industrial operations:

- Power Generation (Coal)
- Mining
- Aggregate/Cement
- Metal Mills
- Pulp & Paper/Sawmills/Forestry
- Water Treatment
- Food Processing
- Warehousing
- Movable Bridges/Structures
- Industrial Fans/Blowers



Fig. 209. SNT metric plummer block.

SPHERICAL ROLLER BEARING SOLID-BLOCK HOUSED UNITS

Equipment operating in metal mill environments needs roller bearing housed units rugged enough to deliver exceptional performance under tough conditions. We designed our spherical roller bearing solid-block housed units for these challenging circumstances.

Made of cast-steel housings and Timken high-performance spherical roller bearings, these solid-block housed units offer protection from contaminants. Available advanced primary seal options and auxiliary steel covers can create another layer of protection for the bearing.

Typical metals applications include tunnel furnace roller bed conveyors, feed rolls, reel drives, loopers, blooming tables, run-out tables, reel drives, transfer decks and re-entry decks. Our spherical roller bearing solid-block housed units can run efficiently on misaligned shafts up to ± 1.5 degrees, without a reduction in life expectancy.

With a full line of precision-made, shaft-locking styles, primary seals, covers, housings and modular design concept, finding the right roller housed unit to fit your metals application is easy.

The Timken family of housed units provides enhanced bearing protection in a multitude of harsh conditions. Our housed units feature robust sealing options – enhancing bearing protection in debris filled, contaminated or high-moisture environments. Industries around the world count on our wide range of housed units to deliver performance and uptime they can count on.

We offer a full line of precision-made locking styles, seals and housings, so you can easily find the right housed unit to fit your application. Timken is the only supplier of spherical roller bearing housed units to offer a steel solid-block housing as standard.

HOUSING STYLES

We offer solid blocks in several styles, including pillow blocks (figs. 210 and 211), flanged blocks (fig. 212), piloted flanges (fig. 213), and take-up blocks (fig. 214) that interchange with competitor units that simply don't offer the strength of these solid-block designs.



Fig. 210. Two-bolt pillow block.



Fig. 211. Four-bolt pillow block.



Fig. 212. Flange block.



Fig. 213. Piloted flange cartridge.



Fig. 214. Take-up block.

WARNING

Failure to observe the following warnings could create a risk of death or serious injury.

Proper maintenance and handling practices are critical. Always follow installation instructions and maintain proper lubrication.

Overheated bearings can ignite explosive atmospheres. Special care must be taken to properly select, install, maintain and lubricate housed unit bearings that are used in or near atmospheres that may contain explosive levels of combustible gases or accumulations of dust such as grain, coal, or other combustible materials. Consult your equipment designer or supplier for installation and maintenance instructions.

Do not use excessive force when mounting or dismounting the unit.

Follow all tolerance, fit and torque recommendations.

Always following the Original Equipment Manufacturer's installation and maintenance guidelines.

Ensure proper alignment.

Never weld housed units.

Do not heat components with an open flame.

Do not operate at bearing temperatures above 250°F (121°C).

LOCKING CONFIGURATIONS

We offer multiple locking solutions, including the eccentric and V-Lock® designs:

EC Series – Eccentric Lock (fig. 215):

- Extra heavy duty.
- Increased shaft holding power.
- Reduced shaft damage under extreme shock loads.
- Designed not to release in reversing applications.

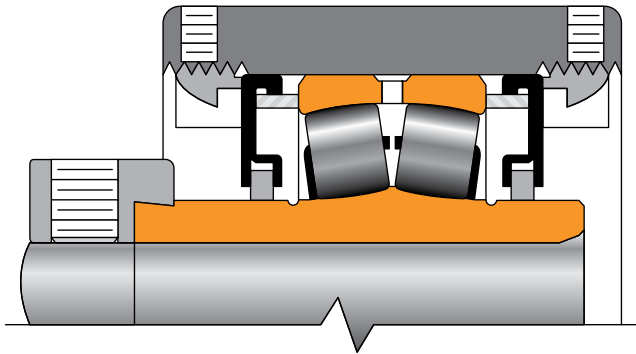

Fig. 215. EC series – eccentric lock.

V-Lock® Series – Double-Taper Lock (U.S. Pat. No. 7344313) (fig. 216):

- Extreme heavy duty.
- 360 degree shaft holding.
- Designed to eliminate over tightening.
- Mechanical withdrawal for easier removal.
- Larger bearing and higher load rating compared to competitive products having same bore size.

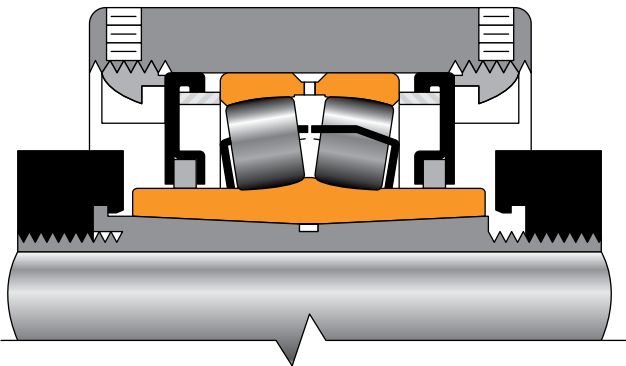

Fig. 216. V-Lock® series – double-taper lock (U.S. Pat. No. 7344313).

SEALING OPTIONS

The three principle sealing options used in the metals industry include:

Labyrinth Seals – DuPont™ Teflon® (fig. 217):

- High-speed applications.
- Superior in moist and dirty conditions.
- Able to operate at high temperatures.
- Resistant to most chemicals.
- Abrasion-resistant.

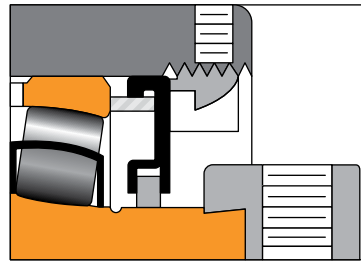

Fig. 217. Labyrinth Seal.

Triple-Lip Seals – Nitrile:

- Self-purging.
- Excellent in moist and dirty applications.
- Chemical- and corrosion-resistant.

Triple-Lip Seals – Urethane (fig. 218):

- All the benefits of Nitrile, plus resistance to abrasion.

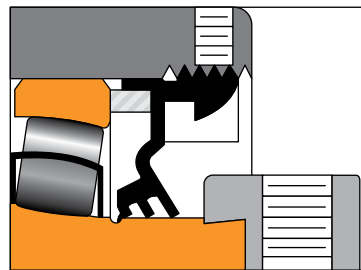

Fig. 218. Triple-lip seals.

DuPont™ Teflon® is a registered trademark of E. I. du Pont de Nemours and Company or its affiliates.

AUXILIARY COVERS



Fig. 219. Optional auxiliary covers.

Housed unit roller bearings get extra protection with rugged, cost effective covers (fig. 219) designed to fight heavy contamination in industries with particulate challenges. These steel covers use black oxide for enhanced corrosion protection.

TIMKEN® TYPE E TAPERED ROLLER BEARING HOUSED UNITS

Timken engineers have applied more than 110 years of expertise in bearing technology – and leadership in tapered roller bearings – to bring you an optimized performance tapered roller bearing housed unit. We have improved our own design to create the new standard in performance. Timken delivers the highest dynamic load ratings in the industry. From the bearings, seals and grease to housings and collars, our innovative design incorporates features that can help withstand the most demanding application conditions – resulting in less downtime, reduced maintenance intervals and an overall lower cost of ownership. We have optimized the core components so that their performance is elevated to a level we consider as the next generation of roller housed units. How do we do it? The answer is in our unique product design.

ENHANCED-PERFORMANCE BEARINGS

Timken® Type E roller bearings have a significantly higher load carrying capability. We have designed in enhanced surface textures and optimized profiles resulting in the highest load ratings in the industry. Our Type E bearings also experience lower internal contact stresses and frictional drag. Beyond bearing life, these bearings are designed to deliver the ability to manage up to three-times more misalignment than industry-standard designs.

DOUBLE-LIP SEALS

By helping to keep debris and water out while retaining grease longer, maintenance intervals can be reduced, thereby contributing to lower maintenance costs. The seals in our Type E housed units optimize contact geometries that promote greater grease retention and significantly reduce contaminant ingress.

PREMIUM GREASE

Maintenance costs are further reduced due to the extra protection provided by Timken® premium all-purpose industrial grease. Our unique grease formulation contains extreme pressure and antiwear additives as well as corrosion inhibitors. This grease works effectively in applications with operating temperatures ranging from -40° F to +300° F (-40° C to +149° C). It is compatible with calcium and lithium- thickened greases.

HOUSINGS AND LOCKING COLLARS

Our designs incorporate ASTM-A48 Grade 30 Cast Iron for the housing. Featuring better corrosion resistance than the industry-standard powder coating, our electro-disposition coating (e-coating) on the housing and locking collars helps reduce overall maintenance costs by protecting exposed surfaces. In addition, our Type E roller housed units are dimensionally interchangeable with all other leading brands.

TIMKEN® TYPE E TAPERED ROLLER BEARING HOUSED UNITS



Fig. 220. Type E tapered roller bearing.

Timken® Type E tapered roller bearing housed units are available in a wide variety of sizes and configurations to meet the requirements of demanding applications. They are dimensionally interchangeable with current suppliers for all key characteristics, including the bolt hole and shaft centerline dimensions. Popular part numbers are in stock for immediate availability. Metric sizes also are available in shaft diameters ranging from 35 mm to 125 mm.

TIMKEN® QUICK-FLEX® COUPLINGS

In metal manufacturing and processing, motors and gearboxes connect with other moving equipment through shafts held together with couplings. Timken® Quick-Flex® couplings can handle high and low torque and high and low speeds. Plus they are sized to fit virtually all needs. They provide strong links for shafts separated by 25 mm to 3 m in range (1 in. to 120 in.).

Quick-Flex couplings are durable enough to face the challenges of metals mills, yet need minimal maintenance. They are easy to install and require no lubrication. With a lifespan that can match that of the rotating equipment, these couplings help keep the overall cost of ownership competitively low.

The couplings connect motors and gearboxes with other moving equipment. They have the capacity to transmit the same or more torque than a gear, grid, chain or other elastomeric coupling with similar dimensions.

Quick-Flex couplings operate without any metal-to-metal contact. The design helps eliminate interference between coupling hubs that can damage equipment. As needed, operators can replace the elastomeric element quickly and easily without removing the hubs. Because the metal hubs don't wear, the elastomeric element is the only spare part needed.

Quick-Flex couplings handle a variety of metal mill jobs with misalignment of up to 2 degrees:

- Motor to gearbox (low torque/high speed).
- Gearbox to driven equipment (high torque/low speed).
- Drive shaft to driven-shaft applications.

Typical applications include tunnel furnace roller bed conveyors, feed rolls, reel drives, loopers, blooming tables, run-out tables, reel drives, transfer decks, re-entry decks, slitters and coilers.

There are multiple cover and element configuration options able to withstand some of the most extreme environments (figs. 221 and 222).



Fig. 221. Standard coupling (shown with high-speed cover).



Fig. 222. Splined hub coupling (shown with hp cover).

Table 10 below shows the features and benefits for Timken Quick-flex compared to competitors.

TABLE 10. QUICK-FLEX COMPARISON

	Quick Flex	Jaw Coupling	Grid Coupling	Gear Coupling	Chain Coupling	Tire Coupling
Easy to Replace Without Moving Hubs	•		•		•	•
High and Low Torque Ratings	•			•		
High-Speed Capability	•			•		
Low Lifetime Cost	•					
Hubs Not Damaged When Urethane Inserts Need to be Replaced	•					•
No Lubrication Needed	•	•				•
No Hub Teeth Wear	•					
Cushioned Shock	•	•	•			•
Compact Design	•			•	•	

NOTE

Couplings accept shaft misalignment, up to 2 degrees.

POWERFUL CONNECTIONS

Timken Quick-Flex Couplings transmit higher levels of torque in most cases, compared with the corresponding gear coupling. Plus, the elastomeric coupling never needs lubrication because there's no metal-to-metal contact.

QUICK-FLEX INSERTS

STANDARD RED INSERT

- Relatively soft urethane excels in vibrational dampening and cushioning of shock loads.
- Use in reversing applications or applications with quick starting and stopping of high inertial loads.

HIGH TORQUE BLUE INSERT

- Relatively stiff urethane provides moderate flexibility and vibrational dampening.

- Use in applications with moderate to high torque, such as gear, grid or chain-style couplings.

HIGH TEMPERATURE WHITE INSERT

- Withstands application temperatures up to 177° C, 350° F.
- Provides torque capabilities similar to the Quick-Flex blue insert.

HIGHEST TORQUE BLACK INSERT

- Stiffest urethane.
- Use in applications with very high torque, such as gear-style couplings.

Table 11 details the gear coupling comparison by shaft size and torque capabilities.

TABLE 11. GEAR COUPLING COMPARISON BY SHAFT AND TORQUE CAPABILITY

Quick-Flex Series	Quick-Flex Couplings Maximum Torque ⁽¹⁾	Quick-Flex Couplings Maximum Speed ⁽¹⁾	GEAR Coupling Size	AVG GEAR Maximum Torque ⁽²⁾	Torque Improvement	Ranges of Shaft
	kNm in.-lbs.	r/min		kNm in.-lbs.		
QF25	1.4 12,449	7000	1	0.9 7,560	65%	1-6.25" 60MM
QF50	3.0 26,479	6000	1.5	1.9 17,010	56%	2-375" 65MM
QF100	6.1 53,642	4800	2	3.6 31,500	70%	3.00" 75MM
QF175	10 88,257	4200	2.5	6.4 56,700	56%	3.875" 98MM
QF250	13.4 118,930	3800	3	10.7 94,500	26%	4.125" 104MM
QF500	24.8 219,429	3400	3.5	16.4 144,900	51%	4.250" 114MM
QF500	24.8 219,429	3400	4	24.9 220,500	0%	4.250" 114MM
QF1000	35 310,466	3000	4.5	34.1 302,400	3%	6.188" 157MM
QF1890	62.5 553,982	2800	5	46.2 409,500	35%	7.5625" 192MM
QF1890	62.5 553,982	2800	5.5	60.4 535,500	3%	7.5625" 192MM
QF3150	98.3 871,139	2000	6	78.2 693,000	26%	9.125" 231MM
QF10260	188.6 1,670,826	1200	7	113.8 1,008,000	66%	11.250" 285MM
QF10260	188.6 1,670,826	1200	8	149.3 1,323,000	26%	11.250" 285MM
QF10260	188.6 1,670,826	1200	9	202.6 1,323,000	-7%	11.250" 285MM

⁽¹⁾ Based on Timken Quick-Flex coupling with split cover and black elastomeric insert

⁽²⁾ American Gear Manufacturers Association standard

PRECISION CHAIN PRODUCTS

From high temperatures to heavy loads, we engineer the optimum chain for your application to increase uptime and reduce maintenance costs. Our entire range of ANSI standard roller chain, attachment chains and engineered chain meet or exceed American National Standards Institute (ANSI) standard B29.1.



Fig. 223. Large pitch precision roller chain.

DRIVE CHAIN

The following factors must be considered when selecting roller chain for drive applications:

- Source of input power.
- Drive machine type of driven equipment.
- Horsepower to be transmitted.
- Revolutions per minute (RPM) of driving and driven shafts.
- Diameter of driving and driven shafts.
- Center distance of the shafts.

We offer precision roller chain in sizes 35 to 240, including multi strand chain. Features of our chain include:

- **WIDE WAIST** The wide-waist design of 60H and larger chains are manufactured with maximized ball heights from special alloy steels for added strength. The wide link plate profile improves stress distribution, leading to improved fatigue resistance and enhanced performance.
- **SOLID ROLLERS** We utilize solid rollers on all carbon roller chain. The solid roller allows for smooth rotation on the bushing, reducing the impact load as the chain engages the sprocket tooth.
- **FACTORY PRE-LOADING AT 50 PERCENT MUTS** Our chains are pre-loaded to 50 percent of minimum ultimate tensile strength (MUTS), which is especially important for applications involving fixed center-to-center sprockets without take-ups. Applications can withstand shock loads up to 50 percent of the chain's MUTS which minimizes premature elongation.
- **SHOT PEENED PARTS** All precision roller chain rollers and link plates are shot peened for greater fatigue strength.
- **PRELUBRICATION** After final assembly, we hot-dip the roller chain in a special lubricant. This process ensures that all the load-bearing surfaces are initially protected from metal-to-metal contact, improving the wear life of the chain.

In addition to our standard roller chain offering, our Extended Life CHP® series chain features a chrome-hardened pin that can increase the wear life up to three times over conventional premium chains for particularly demanding applications.

For corrosive environments, our Silver Shield CR® series chain combines the strength of our standard roller chain with a zinc-aluminum compound coating to resist corrosion.

For high shock-loading applications, our HZ riveted and cotter series chain feature ballized plates, which provide increased bearing area for optimum press fits, improving fatigue life and working loads. They also feature through-hardened shot-peened pins for protection from unpredictable overloads. Our HZ series is available in sizes 60H to 240H, including multi strand chain.

CONVEYING CHAIN



Fig. 224. E series chain and metal transfer chain.

The following information is needed to design a chain for conveyor applications:

- Type of conveyor (slat conveyor, bucket elevator, etc.).
- Method of chain travel (horizontal, inclined or vertical conveyor).
- Type, weight and size of materials to be conveyed.
- Weight of materials to be transported per foot of conveyor length.
- Conveyor speed.
- Conveyor length.
- Lubrication.
- Considerations for special environments.

For conveying applications, we offer attachment roller chain in sizes 40 to 160 and C2040 to C2160H. These are available in standard carbon steel, stainless steel, Extended Life CHP[®] series and our Silver Shield CR[®] series. We also offer engineered class chain, which is custom designed for your application. Contact your Timken engineer for more information.

WARNING

Failure to observe the following warnings could create a risk of death or serious injury.

Proper maintenance and handling practices are critical. Always follow installation instructions and maintain proper lubrication.

CAUTION

Failure to follow these cautions may result in property damage.

Use only subassemblies for assembling chain strands. Do not use individual chain components and do not mix subassemblies from different chain manufacturers.

Do not reuse sections from damaged chains. Damage from overloading or yielding may be present though not apparent.

Do not use worn chain or install new chain on worn sprockets.

BEARING STORAGE, HANDLING AND INSTALLATION

This section includes information on:

- Bearing packaging and storage.
- Bearing marking.
- Roll neck maintenance guidelines.
- Chock and roll neck maintenance guidelines.
- Mounting and dismounting roll neck bearings.
- Bearing setting techniques.



BEARING PACKAGING AND STORAGE

We supply large-bore bearings used in the metals industry in either individual carton boxes or packed in wooden crates (fig. 225) for the larger sizes.

Our standard packaging protects the product for five years from the original pack date, provided that the customers meet the conditions below:

- The product remains in its original package.
- The product is stored in a clean, dry area.
- The product is not exposed to extreme climate temperatures or humidity.



Fig. 225. Large-bore bearing packaging.

We ship our bearings with a protective lubricant and then a rust-preventative coating. We typically wrap them in a protective paper, plastic bag or aluminum foil bag and ship them in a carton or crate (fig. 225). The rust-preventative coating on the bearing is compatible with most lubricants. Do not wash or clean the bearing when you remove it from its packaging.

NOTE

When receiving new or remanufactured bearings, do not remove the bearings from their packaging until you're ready to install the bearings in the application.

When handling bearings, care must be taken to ensure that they won't rust or corrode. Even a small amount of water or contaminant, left on an unprotected bearing, can result over time in an etched area that will reduce bearing life.

Store bearings on a pallet or shelf in an area where they won't be subjected to high humidity or sudden and severe temperature changes that may result in condensation forming. Do not store bearings directly on concrete floors, where water can condense on them. An assembled bearing must be fixed in its box to prevent movement of rings against rollers since vibration can occur during shipment. Bearings should always be placed with their axis vertical in order to avoid ring distortion.

If bearings are removed from service and are going to be stored for future use, they should receive a thorough cleaning and be covered with a rust-preventative fluid, as well as an adequate wrapping, to protect against rust and corrosion for the intended storage duration.

BEARING MARKING

IDENTIFICATION AND TRACEABILITY

To facilitate identification and traceability, Timken bearings may include the following marking in addition to the part number:

- **Manufacturing source:** We mark a plant code or symbol on our products.
- **Country of origin:** We typically mark the country of origin on finished bearing products. If we don't mark the country of origin on the product, we will mark a plant code.
- **Date code:** This letter code uniquely links every component with its manufacturing history and the heat of steel used.
- **Serial number:** We mark components used in non-interchangeable bearing assemblies with a serial number and face designations to enable endusers to reassemble components from the same assembly and stack them in the proper sequence.

ASSEMBLY SEQUENCE (STACKING)

When you stack up a bearing assembly, you must follow the proper assembly sequence for the bearing to maintain the correct setting.

Tapered roller bearings feature a lettering system to help facilitate proper stacking of all assemblies with two or more rows. The assembly components are lettered in alphabetical order. These letters are marked on each side of the inner and outer rings, whereas the spacers include marks on the outside diameters.

For cylindrical roller bearings, each roller row must always be assembled with the corresponding outer race. You can easily I.D. the assembly components by matching race letters, serial number and the date code. This requirement is important, as each roller row is matched to its outer race to maintain the correct diameter under rollers (DUR). You can interchange inner rings if they have the same part number and assembly code.

A schematic marking example is illustrated (fig. 226) for typical four-row tapered and cylindrical roller bearings used in roll neck applications.

OUTER RING LOAD-ZONE QUADRANTS (FOUR-ROW BEARINGS)

Because the bearing outer rings remain stationary in the chocks, one part carries the rolling load at any one time. This portion is called the load zone. Most tapered and cylindrical roll neck bearing outer rings are marked (fig. 226) on their faces to show four quadrants. These markings enable operators to keep a record of which quadrants have been used in the load zone.

A good practice is to mount the bearing with quadrant number one of each outer ring in the load zone, then go through two, three, four on subsequent inspections. Next, repeat the procedure starting at one. If the load-zone position is not obvious, as is the case with work roll chocks with roll bending, it is common to use the zone adjacent to the pass line as the reference for periodically rotating the outer rings to index the sector that will carry the load zone.



Fig. 226. Example of quadrant marking.

The roll neck bearing service record card (fig. 227) offers an easy means of keeping a record of the load zones that have been used. The rotation of the outer rings at every inspection will extend the useful life of the bearing by incrementally distributing the load over the entire outer-ring raceway. In all cases, any spall in the raceway that has been repaired should be kept out of the load zone.

Roll Neck
Bearing Service
Record

TIMKEN

PLANT _____		MILL _____		BEARING LOCATION _____		BACK-UP ROLL <input type="checkbox"/>		WORK ROLL <input type="checkbox"/>		LUBRICANT _____						
BEARING																
SERIAL NUMBER _____		MAKE _____		Part Number _____				DOSE SPACER NO. _____								
DRAWING NUMBER _____		SIZE _____		2 ROW <input type="checkbox"/>		DATE RECEIVED _____		DATE SCRAPPED _____		TOTAL TONN _____						
				4 ROW <input type="checkbox"/>						BEARING LATERAL (IN) _____						
										BEARING SPACERS AT _____ LATERAL _____						
TIME IN SERVICE	IN	OUT	DRAG NO.	ROLL NO.	SPIN NO.	POSITION	UPPER TIME	DATE	OUT TIME	SPREAD	SPRICE	DOSE	TOTAL	DUR		
1						NO								REPAIR	REPAIR	REPAIR
2						NO								REPAIR	REPAIR	REPAIR
3						NO								REPAIR	REPAIR	REPAIR

Fig. 227. The Timken roll neck bearing service record card.

ROLL NECK BEARING MARKING EXAMPLES

FOUR-ROW TAPERED ROLLER BEARING MARKING – 2TDIW

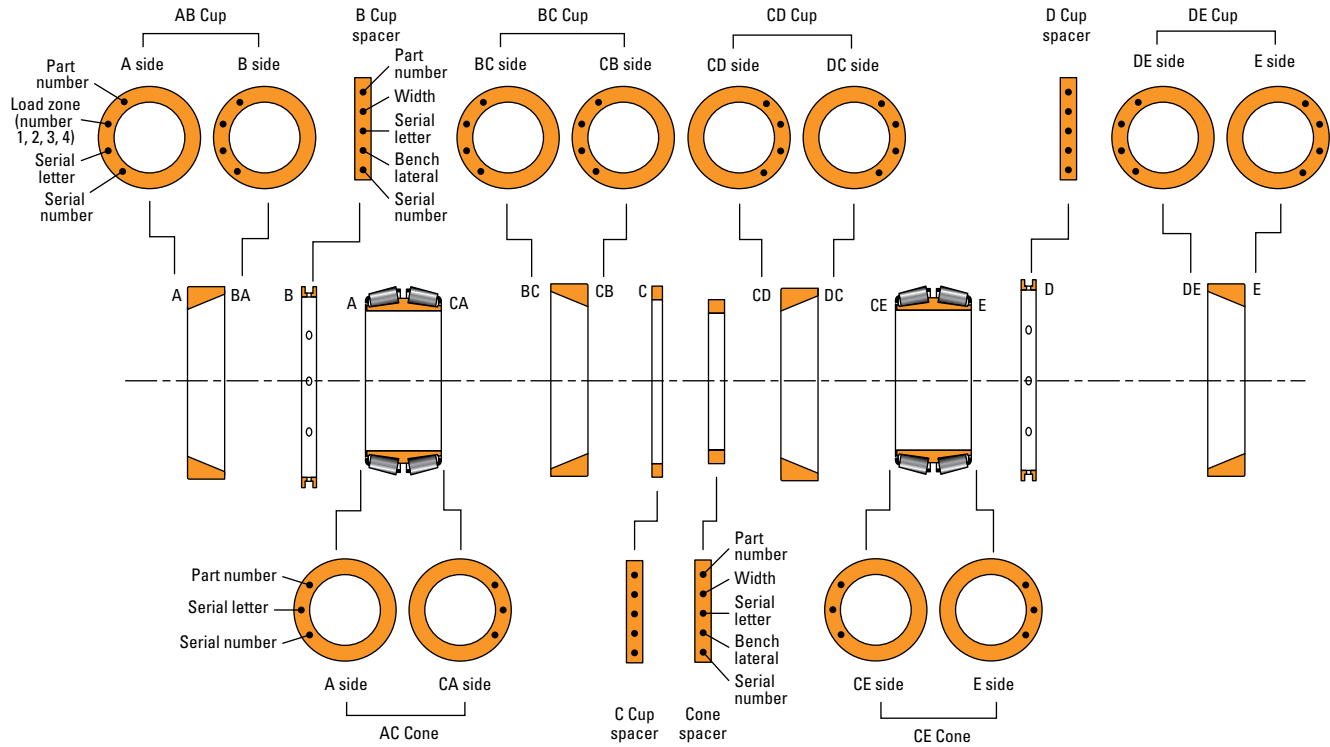

Fig. 228. Four-row tapered roller bearing marking – 2TDIW.

FOUR-ROW CYLINDRICAL ROLLER BEARING MARKING – RX

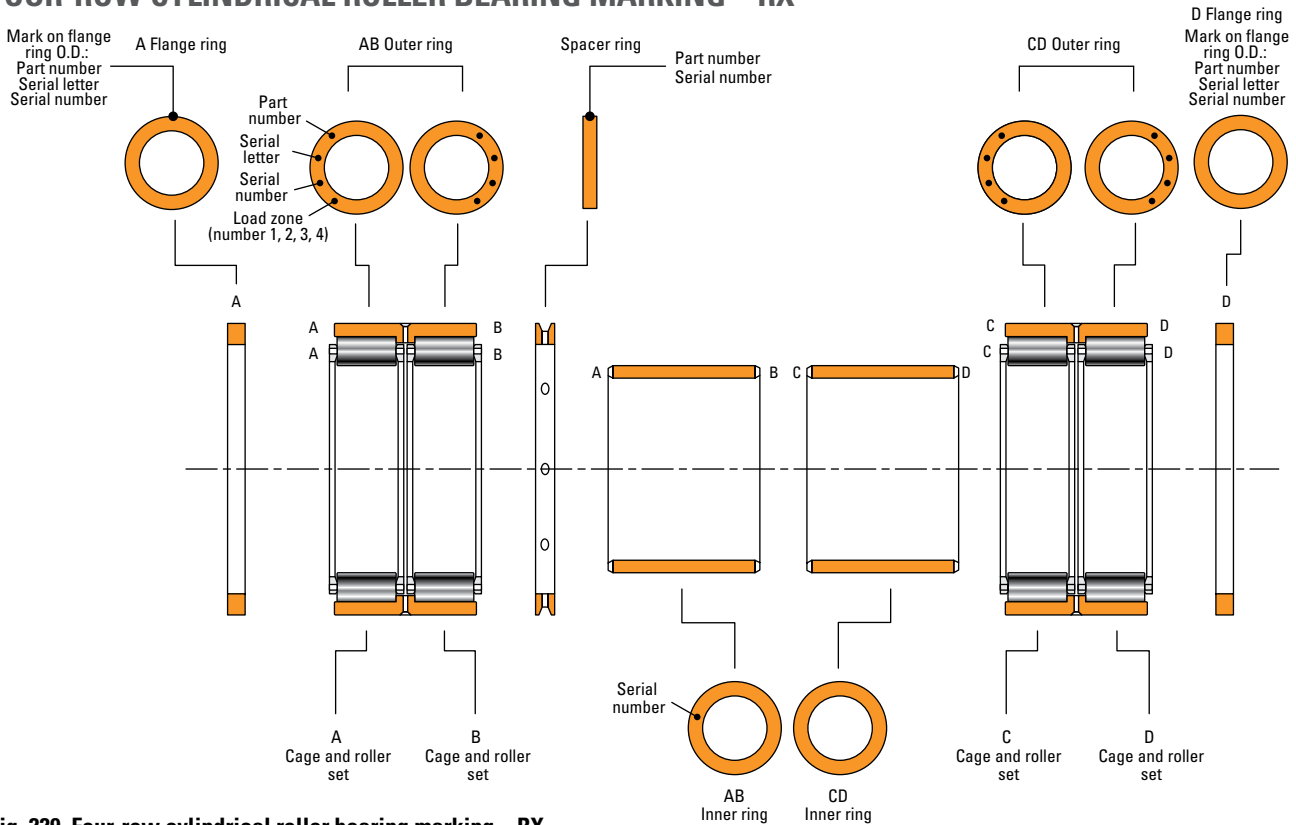

Fig. 229. Four-row cylindrical roller bearing marking – RX.

ROLL NECK MAINTENANCE GUIDELINES

The useful life of any bearing depends on handling, mounting and maintenance practices. This rings especially true in steel industry applications, where operating conditions tend to be harsh, loads are heavy and contamination from dirt and scale are common. Bearing problems can result in costly downtime, equipment damage and breakdowns. To attain reliable operation with high equipment performance and the lowest possible maintenance costs, follow proper practices. These include bearing removal, handling, cleaning, inspection and installation. Always follow the original equipment manufacturer's maintenance instructions to maintain product integrity and performance levels.

BEARING REMOVAL

The bearing removal procedure varies according to the bearing type. But regardless of the type, you must remove the bearing with extreme care. If done incorrectly, you can damage the bearing, as well as shafts and/or housings, requiring expensive repairs.

For smaller bearings, there are a variety of standard pullers available to assist with bearing removal.

For large bearings installed with a tight or press fit, or that have become locked in place on a shaft and can't be removed with a mechanical puller, you can heat the inner ring of the bearing to ease removal. If you need to reuse the bearing or return it for repair, do not use heat from a torch. It can alter the bearing's hardness and metallurgical structure, resulting in irreparable damage. In these situations, an induction heater should be used.



WARNING

Failure to observe the following warnings could create a risk of serious injury.

Proper maintenance and handling practices are critical. Always follow installation instructions and maintain proper lubrication.

Tensile stresses can be very high in tightly fitted bearing components. Attempting to remove such components by cutting the cone (inner race) may result in a sudden shattering of the component causing fragments of metal to be forcefully expelled. Always use properly guarded presses or bearing pullers to remove bearings from shafts, and always use suitable personal protective equipment, including safety glasses.

BEARING HANDLING

You can lift and move large bearings using a variety of slings, hooks, chains and mechanical devices.



Fig. 230. Handling bearing components with threaded lifting hole.

We manufacture some large bearings with tapped holes in the face of inner rings, pin-type cage rings or outer rings. You can mount eyebolts or other points of attachment in these lifting holes (fig. 230). You can also insert specially designed lifting pins in the outer ring lubrication holes.

A clean, heavy-duty nylon sling provides one of the best means of handling large bearing components, because it eliminates the possibility of burring or scratching.

Regardless of what method is used to lift the bearings, use care to avoid damaging any of the bearing surfaces. Be especially cautious when lifting or moving (turning) bearings equipped with a protruding cage. The cage is typically the most fragile component of the bearing and can be easily damaged.

All lifting equipment (eyebolts, slings, etc.) need to be well designed, maintained and certified by the appropriate governing body. In all cases, extreme care should be taken to avoid human injuries.

BEARING CLEANING

For cleaning large numbers of bearings, use special cleaning tanks containing either neutral oil (20 cSt @ 40° C [104° F]) heated at 150° C (302° F) or appropriate alkaline cleaners mixed with hot water. Many typically use electrical coils to heat the tanks. Final cleaning and rinsing are done by suspending the bearing and using a hose to flush away any remaining contamination using alkaline solutions (trisodium phosphate, sodium metasilicate or soda ash) mixed to 1.5 to 2 percent in hot water.

After cleaning, carefully inspect the bearing for damage and wear, and repair it if necessary. If the bearing is not going back to operation immediately, cover it with a coating of light oil or preservative and pack it properly to protect against rust and corrosion.

BEARING INSPECTION AND MINOR REPAIR

When inspecting bearings, make sure that you clean the inspection area and ensure it's free from dirt and debris to avoid contaminating the bearing. Inspect the races of the outer and inner ring for any unusual wear, nicks or spalls. Also inspect the surface of each roller for unusual wear or spalls. Inspect for damage, wear or discoloration on bearings with ribs or flanges. For tapered roller bearings, inspect the large rib.

On smaller tapered roller bearings, the rollers and cage may prevent a clear view of the cone race. Check for any nicks or spalls by sliding a soft metal probe under the cage and working it back and forth across the cone race to feel the condition. You can catch spalls and nicks quite easily with this tool.

Larger pin-type cage tapered roller bearings may have one or two rollers for race inspection that are held in place with threaded removable pins. You can dismount these pins by taking out the locking wire and unscrewing the pin. After completing the inspection, reinstall the inspection roller(s), retighten the threaded pin(s) and place the locking wire(s) (figs. 231 – 233).

We also offer several other resources to assist you in analyzing bearing damage, including online resources at www.timken.com and publications with photos representing all common types of bearing damage.

To avoid the presence of sharp edges and particles that may detach in operation, rework minor damage such as superficial staining, light spalls, nicks or gouges. You can perform this rework with hand tools such as an emery cloth, a hand grinder and wire brushes.



Fig. 231. Removing locking wire from an inspection pin.



Fig. 232. Removing the threaded pin.



Fig. 233. Inspecting inner race.

BEARING INSTALLATION

HEATING OR COOLING METHODS

In applications that require a tight fit of the inner ring on the shaft, it is always easier to install the bearing if it is physically expanded by heating. For applications that require a tight fit of the outer ring in housing, it also may be possible to heat the housing or to freeze the outer ring to facilitate installation.

Avoid overheating or overfreezing bearing components before their installation. It may change the bearing's steel structure, hardness and geometry, resulting in reduction in bearing life.

Determine the required heating temperature to expand the ring to the needed loose fit value prior to mounting. Use the following equations:

Required heating or cooling temperature (T° C)

Heating:

$$T^{\circ} C = \text{ambient } \theta^{\circ} + \frac{\Delta s \times 2}{\emptyset \times 12 \times 10^{-6}}$$

or

$$T^{\circ} F = \text{ambient } \theta^{\circ} + \frac{\Delta s \times 2}{\emptyset \times 6.3 \times 10^{-6}}$$

Cooling:

$$T^{\circ} C = \text{ambient } \theta^{\circ} - \frac{\Delta s \times 2}{\emptyset \times 12 \times 10^{-6}}$$

or

$$T^{\circ} F = \text{ambient } \theta^{\circ} - \frac{\Delta s \times 2}{\emptyset \times 6.3 \times 10^{-6}}$$

Where:

Δs = Diametric tight fit in mm (in.)

\emptyset = Shaft diameter in mm (in.)

2 = Security factor for handling

Example A (for heating):

A 250 mm (9.843 in.) bore bearing inner ring fitted with 0.100 mm (0.004 in.) tight fit will require to be heated to approximately 85° C (185° F). Under this condition, the bore will expand by 0.200 mm (0.008 in.) to overcome the 0.100 mm tight fit.

$$T^{\circ} C = \frac{0.100 \times 2}{250 \times 12 \times 10^{-6}} + 20 = 86.6 \text{ rounded to } 85^{\circ} C (185^{\circ} F)$$

Example B (for freezing):

A 350 mm (13.78 in.) outside diameter bearing outer ring fitted with 0.150 mm tight fit will require to be frozen to -50° C. Under this condition, the outside diameter will contract by 0.300 mm (0.0118 in.) to overcome the 0.150 mm (0.006 in.) tight fit.

$$T^{\circ} C = 20 - \frac{0.150 \times 2}{350 \times 12 \times 10^{-6}} = -51.4 \text{ rounded to } -50^{\circ} C (-58^{\circ} F)$$

As a general practice, table 12 provides guidelines for heating and cooling standard class bearing rings during installation or removal (temperatures and times are maximum limits and should not be exceeded):

TABLE 12. HEATING AND COOLING GUIDELINES

Heating Components		Freezing Components	
90° C (195° F)	24 hours	-55° C (-65° F)	1 hour
120° C (250° F)	8 hours		
150° C (300° F)	4 hours		

FREEZING BEARINGS

Obtain low temperatures by using a mixture of alcohol or dry ice, or by using a thermostatically controlled freezer. When the bearing returns back to ambient room temperature, dry and lubricate the bearing components to eliminate the condensed water and avoid rust. Never dip bearing components in liquid nitrogen.

HEATING BEARINGS

Whatever the method used to heat bearing components, you must continuously control the temperature. Also, take extreme care to ensure the needed safety equipment is in place to avoid maintenance operator burn injuries.

Heating methods will depend on bearing size and volume. Some methods include:

- Oil-bath heating.
- Infrared lamp or shop floor bulb heating.
- Dry industrial oven heating.
- Induction heating.
- Direct-flame heating.

 **WARNING**
Failure to follow these cautions could create a risk of injury.

Remove oil or rust inhibitor from parts before heating to avoid fire and fumes.

OIL-BATH HEATING

For large-bore bearings or housings heated using an oil bath maximum temperature and time should not exceed the suggested values described in table 12 on page 149 for Timken bearings and the temperature must be constantly controlled.

You should position the bearing in the center of the tank and not allow it to come in direct contact with the heat source. This would result in locally exceeding the maximum temperature.

As a rule of thumb, bearings typically require at least one minute of soak time per millimeter (25 min./in.) of inner ring cross section to fully heat in an oil tank. A general suggestion: leave the component submerged for at least 30 minutes.

INFRARED OR SHOP FLOOR BULB HEATING

Use infrared or shop floor bulb heating only for small size bearings found in the auxiliary equipment. Position the bearing at an adequate distance relative to the infrared lamp or light bulb without contacting it. The time to heat should be evaluated based on experience and tests, considering the lamp or bulb power, the placement distance and the environmental conditions like airflow presence or ambient temperature. This heating method requires regular checks or continuous temperature monitoring to avoid exceeding the maximum temperature and generating reduced race hardness.

DRY INDUSTRIAL OVEN HEATING

This heating method uses an electrical oven to heat a confined volume. The configuration of the volume dictates the size of the bearing that can be heated. To heat a bearing, an electrical oven must meet the requirements below:

- The heating parameters are controlled (target temperature, heating rate).
- The temperature gradient in the heated volume is minimized.
- There needs to be easy access to the heated bearing in the oven to avoid bearing cooling.

INDUCTION HEATING

Using induction heating technology is the simplest method of safely heating bearings. Induction heating systems work very quickly and safely while offering a lot of other advantages:

- Full control of both temperature and time.
- Environmentally friendly.
- Easy to use.
- Cost effective.
- Multi-purpose applications.

See page 131 for information on our induction heaters.

DIRECT FLAME

Only use this method to dismount bearings, providing that you don't plan to re-use the bearing. Do not use direct flame to install a bearing.

NOTE

Never expose any surface of a bearing to the flame. Do not heat bearing beyond 149 °C (300 °F).

CHOCK AND ROLL NECK MAINTENANCE GUIDELINES

Chock bores, roll neck seats and shoulders are important contact surfaces that are subject to wear and distortions. Maintain these surfaces for optimal bearing performance. Chocks that have seen extended service may be reconditioned to restore the wear surfaces (fig. 234).

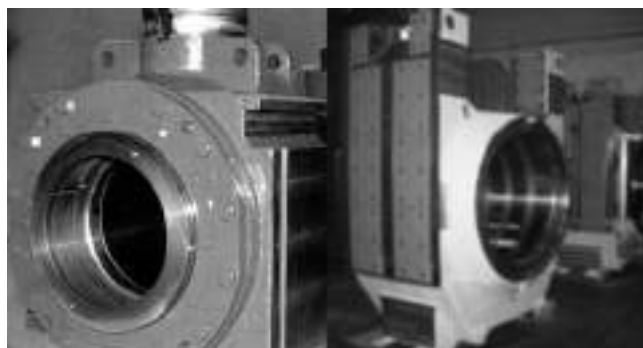

Fig. 234. Reconditioned chocks.

INSPECTION OF CHOCK WEAR PLATES

Inspect rocker plates to make sure they are in serviceable condition and have proper bevels permitting the chock to rock and align under roll neck deflections. Check keeper plates for wear and cracking. This will ensure that you maintain proper clearance between the chock and the windows in the mill frame.

The keeper plates on the operating side are set over flanges on the chock face and bevelled as shown in fig. 235. This permits the chock to rock and follow the normal deflection of the roll and the neck. The keeper plates on the work rolls are similarly designed with a flat and a double chamfer at both ends to permit complete flexibility between the work roll chock and the legs of the backup roll chocks or the piston blocks in which they are mounted. This flexibility ensures that the thrust loads developed in the mill are carried into the bearing without a significant overturning moment, should misalignment occur between the normal axes of the work rolls and the axes of the backup rolls.

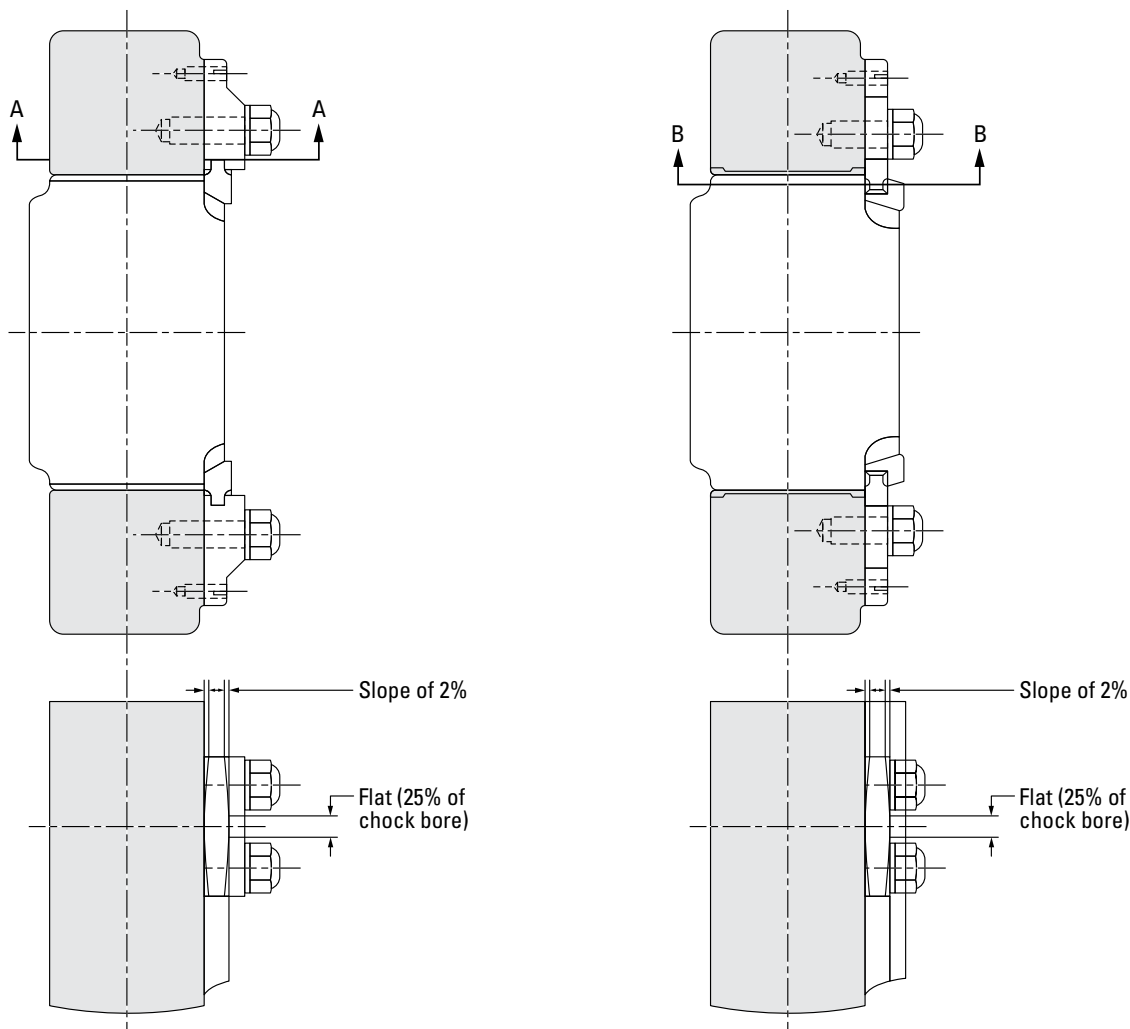

Fig. 235. Keeper plate configuration.

BEARING STORAGE, HANDLING AND INSTALLATION

CHOCK AND ROLL NECK MAINTENANCE GUIDELINES

Fig. 236 shows a usual method of mounting the work roll in the legs of the backup roll chocks. The work roll chocks are fixed against axial movement into the backup roll chocks on the operating side of the mill and float on the drive side of the mill. You must have sufficient clearance between the work roll chocks and the backup roll chock legs to allow the work roll chocks to float freely. Wear plates are generally used between the work roll chocks and the backup roll chock legs, as well as between backup roll chocks

and the window. Check wear plates on a regular basis to prevent introducing roll crossing and/or misalignment, which adversely influence bearing life.

The rocker aligning device between the bottom of the backup roll chocks and the base of the window permits these chocks to rock to follow the roll and neck deflections. You'll see different rocker designs in fig. 237.

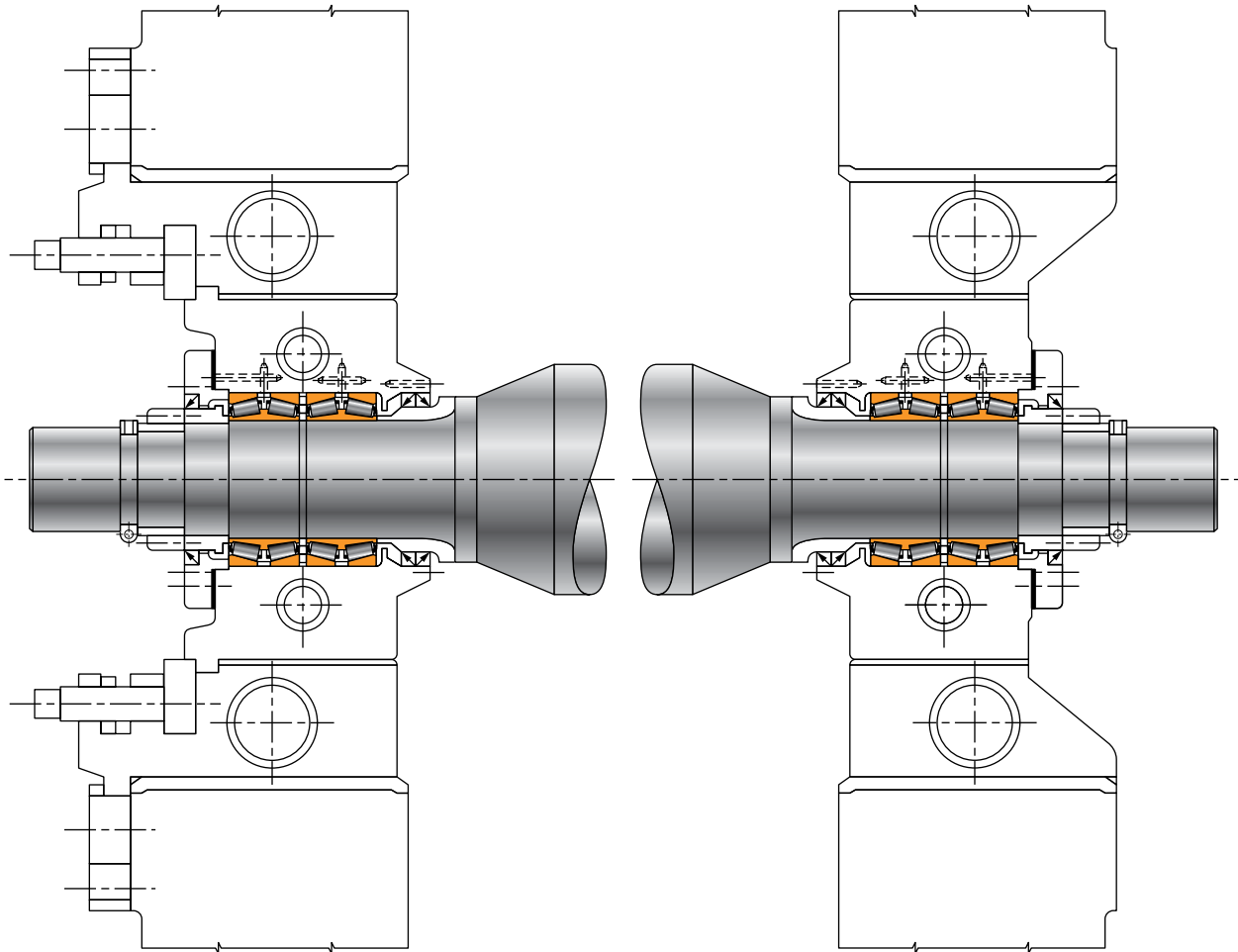

Fig. 236. Example of mounting of the work roll in the legs of the backup roll chocks.

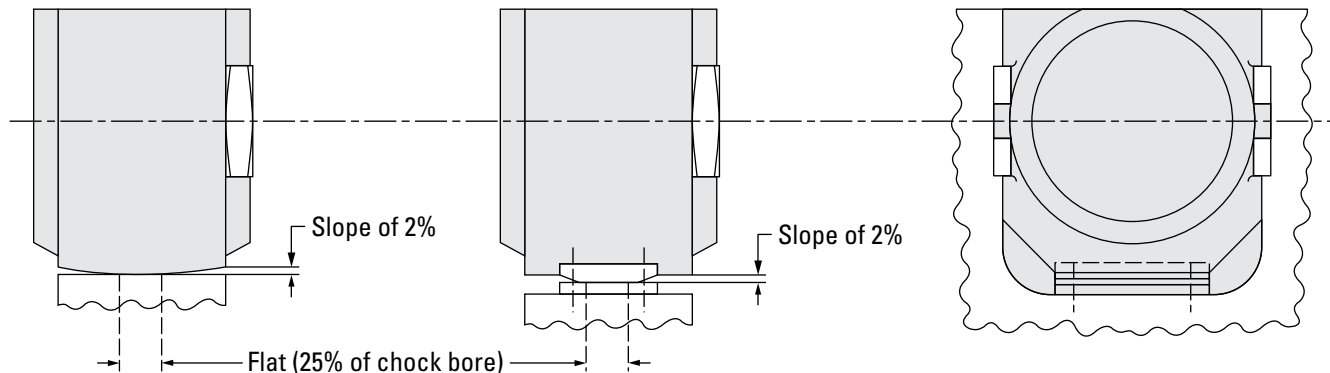

Fig. 237. Rocker aligning devices.

INSPECTION OF CHOCK BORE



Fig. 238. Polishing out chock bore corrosion.

Regularly inspect the chock bores and measure them at the time of bearing inspection. If the chocks need to be reconditioned, it is done in sets of four to help maintain a common center line of the mill. To complete a chock inspection, remove the bearing assembly. Thoroughly clean the chock, including all lubrication and vent holes. If you use oil-mist or air-oil lubrication, pay special attention to ensure that the mist re-classifier fittings or air-oil pipes are clean.

Polish out heavy corrosion or fretting in the chock bore (fig. 238). Make sure that backing shoulders in the chock are free of burrs to allow proper seating of the cups or outer rings. Burrs can detach from the chock and lead to spalling and premature equipment damage if they enter the bearing.

Thoroughly check all seals and replace any that are worn or torn. Seals play a major role in keeping lubricant in the bearing and contaminants out.

Make periodic chock checks (at least once per year also refer to the equipment manufacturer's instructions) for bore size and geometry, and record them to confirm they are still within the acceptable limits of the original manufacturer's specifications for size, roundness and taper. Chocks can become distorted after long periods of service. See tables 13 and 14 for suggestions for permissible chock bore out-of-roundness and over-size limits due to service for inch and metric system bearings respectively.

TABLE 13. CHOCK BORE REWORK LIMITS WHEN USING INCH TOLERANCE SYSTEM BEARINGS

Chock Bore Rework Limits						
Size Range Bearing O.D.		Chock Bore – Variance from Nominal Cup O.D.			Out of Round	Taper
		New		Reworked		
Over	Incl.	Min.	Max.	Max.	Max.	Max.
mm. in.	mm. in.	mm. in.	mm. in.	mm. in.	mm. in.	mm. in.
	304.8 12.00	+0.051 +0.0020	+0.076 +0.0030	+0.200 +0.0080	0.080 0.0030	0.040 0.0015
304.8 12.00	609.6 24.00	+0.102 +0.0040	+0.152 +0.0060	+0.380 +0.0150	0.150 0.0060	0.050 0.0020
609.6 24.00	914.4 36.00	+0.152 +0.0060	+0.229 +0.0090	+0.580 +0.0230	0.230 0.0090	0.080 0.0030
914.4 36.00	1219.2 48.00	+0.203 +0.0080	+0.305 +0.0120	+0.760 +0.0300	0.310 0.0120	0.100 0.0040
1219.2 48.00	1524 60.00	+0.254 +0.0100	+0.381 +0.0150	+1.010 +0.0400	0.380 0.0150	0.130 0.0050
1524 60.00		+0.305 +0.0120	+0.432 +0.0170	+1.220 +0.0480	0.460 0.0180	0.150 0.0060

NOTE: For tapered bore bearings in mills running at 1200 mpm (4000 fpm) or higher consult with your Timken engineer.

TABLE 14. CHOCK BORE REWORK LIMITS WHEN USING METRIC TOLERANCE SYSTEM BEARINGS

Chock Bore Rework Limits						
Size Range Bearing O.D.		Chock Bore – Variance from Nominal Cup O.D.			Out of Round	Taper
		New		Reworked		
Over	Incl.	Min.	Max.	Max.	Max.	Max.
mm. in.	mm. in.	mm. in.	mm. in.	mm. in.	mm. in.	mm. in.
	120.0 4.72	+0.036 +0.0014	+0.058 +0.0023			
120.0 4.72	180.0 7.09	+0.043 +0.0017	+0.068 +0.0027	+0.170 +0.0070	0.080 0.0030	0.040 0.00150
180.0 7.09	250.0 9.84	+0.050 +0.0020	+0.079 +0.0031			
250.0 9.84	315.0 12.40	+0.056 +0.0022	+0.088 +0.0035			
315.0 12.40	400.0 15.75	+0.062 +0.0024	+0.119 +0.0047	+0.330 +0.0130	0.150 0.0060	0.050 0.0020
400.0 15.75	500.0 19.68	+0.068 +0.0027	+0.131 +0.0052			
500.0 19.68	630.0 24.80	+0.076 +0.0030	+0.146 +0.0058			
630.0 24.80	800.0 31.50	+0.080 +0.0031	+0.160 +0.0063	+0.490 +0.0190	0.230 0.0090	0.080 0.0030
800.0 31.50	1000.0 39.37	+0.086 +0.0034	+0.176 +0.0069			
1000.0 39.37	1250.0 49.21	+0.098 +0.0038	+0.203 +0.0080			
1250.0 49.21	1600.0 63.00	+0.110 +0.0043	+0.235 +0.0093	+0.860 +0.0340	0.380 0.0150	0.130 0.0050
1600.0 63.00		+0.120 +0.0047	+0.270 +0.0106			

NOTE: For tapered bore bearings in mills running at 1200 mpm (4000 fpm) or higher consult with your Timken engineer.

Have your maintenance department keep a record of each chock inspection and measurement and they can make repairs when necessary. Fig. 239 illustrates a typical chock record sheet.

CHOCK BORE RECORD SHEET

Chock ballster _____ Date _____
 Mill user _____ Service rep. _____
 Type chock: Back-up roll () Work roll () Type roll _____

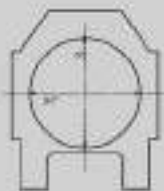
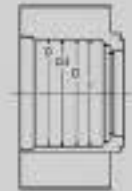
Chock bore print info: _____

Check	Position		0°	90°	Average
		0			
		90			
		Average			
		0			
		90			
		Average			
		0			
		90			
		Average			

Fig. 239. Chock record sheet.

INSPECTION OF ROLL NECKS

In roll necks using tapered roller bearings, the cones typically have a loose fit to the shaft roll neck and will creep on the necks, causing wear. Lubricating the necks prior to bearing installation can limit wear. Bearing face slots, spiral grooves in the bearing bore, or oil holes in the cones are sometimes used to improve roll neck lubrication.

After cleaning, inspect the roll neck and check it for size and general condition. See tables 15 and 16 on the following page for suggestions for permissible service wear limits on roll necks for four-row tapered roller bearings type TQOW or 2TDIW.



Fig. 240. Restoring minor roll neck damage.

Store or file down any raised nicks or gouges on the roll neck before reassembly (fig. 240). Heavy burrs can cause difficulties when mounting the cones on the neck, particularly on new rolls with nominally sized necks. Polish the seal rubbing surfaces if required. Remove sharp edges that could cut the seal lip at assembly. Coat the roll neck with a suitable lubricant to help combat scuffing and wear. Carefully handling the chock and bearing while sliding it on or off the roll neck will help to avoid seal mounting damage.

Have your maintenance department keep a record of each roll neck inspection and measurements and make neck repairs when necessary. Fig. 241 on page 155 illustrates a typical roll neck record card.

TABLE 15. ROLL NECK DIAMETER WEAR LIMITS WHEN USED WITH LOOSE-FIT INCH SYSTEM BEARINGS

Roll Neck Diameter Wear Limits						
Bearing Bore		Roll Neck Diameter Variance from Bearing Bore Nominal			Taper	
		New		Reworked		
Over	Incl.	Min.	Max.	Min.	Max.	
mm in.	mm in.	mm in.	mm in.	mm in.	mm in.	
	127.0 5.00	-0.127 -0.0050	-0.102 -0.0040	-0.280 -0.0110	0.040 0.0015	
127.0 5.00	152.4 6.00	-0.152 -0.0060	-0.127 -0.0050	-0.360 -0.0140	0.040 0.0015	
152.4 6.00	203.2 8.00	-0.178 -0.0070	-0.152 -0.0060	-0.430 -0.0170	0.050 0.0020	
203.2 8.00	304.8 12.00	-0.203 -0.0080	-0.178 -0.0070	-0.510 -0.0200	0.050 0.0020	
304.8 12.00	609.6 24.00	-0.254 -0.0100	-0.203 -0.0080	-0.610 -0.0240	0.080 0.0030	
609.6 24.00	914.4 36.00	-0.330 -0.0130	-0.254 -0.0100	-0.840 -0.0330	0.100 0.0040	
914.4 36.00	1219.2 48.00	-0.406 -0.0160	-0.305 -0.0120	-1.120 -0.0440	0.130 0.0050	
1219.2 48.00		-0.432 -0.0170	-0.305 -0.0120	-1.220 -0.0480	0.150 0.0060	

TABLE 16. ROLL NECK DIAMETER WEAR LIMITS WHEN USED WITH LOOSE-FIT METRIC SYSTEM BEARINGS

Roll Neck Diameter Wear Limits						
Bearing Bore		Roll Neck Diameter Variance from Bearing Bore Nominal			Taper	
		New		Reworked		
Over	Incl.	Min.	Max.	Min.	Max.	
mm in.	mm in.	mm in.	mm in.	mm in.	mm in.	
	120.0 4.72	-0.155 -0.0061	-0.120 -0.0047	-0.300 -0.0120	0.040 0.0015	
120.0 4.72	180.0 7.01	-0.185 -0.0073	-0.145 -0.0057	-0.380 -0.0150	0.040 0.0015	
180.0 7.01	250.0 9.84	-0.216 -0.0085	-0.170 -0.0067	-0.460 -0.0180	0.050 0.0020	
250.0 9.84	315.0 12.40	-0.242 -0.0095	-0.190 -0.0075	-0.540 -0.0210	0.050 0.0020	
315.0 12.40	400.0 15.75	-0.267 -0.0105	-0.210 -0.0083	-0.680 -0.0270	0.080 0.0030	
400.0 15.75	500.0 19.66	-0.293 -0.0115	-0.230 -0.0091			
500.0 19.66	630.0 24.80	-0.330 -0.0130	-0.260 -0.0102			
630.0 24.80	800.0 31.50	-0.400 -0.0157	-0.320 -0.0126	-0.940 -0.0370	0.100 0.0040	
800.0 31.50	1000.0 39.37	-0.450 -0.0177	-0.360 -0.0142			
1000.0 39.37	1250.0 49.21	-0.530 -0.0209	-0.425 -0.0167	-1.240 -0.0490	0.130 0.0050	
1250.0 49.21		-0.600 -0.0236	-0.475 -0.0187	0.130 0.0050	0.150 0.0060	

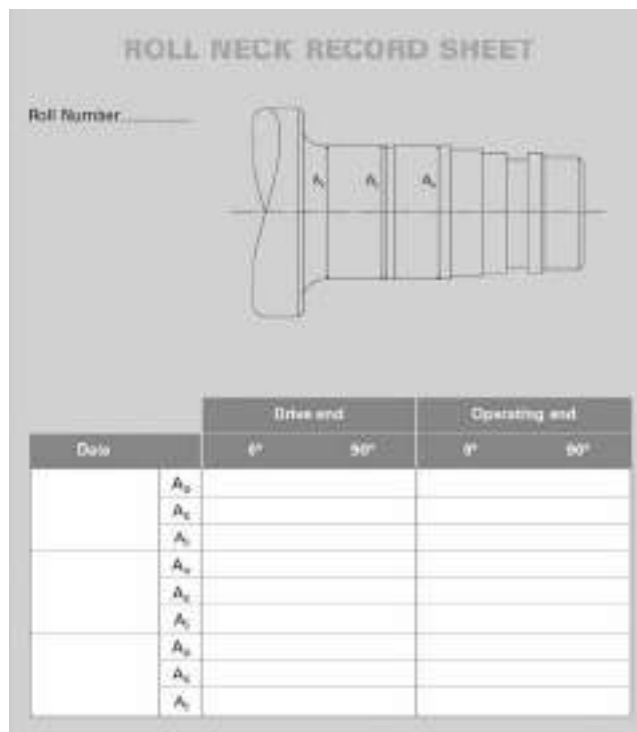

Fig. 241. Typical roll neck record card.

In roll necks mounted with cylindrical roller bearings, the inner ring may be re-ground on the roll neck. In this case:

- The minimum outside diameter of the cylindrical roller bearing inner rings must be respected to retain the required radial internal clearance, once the bearing outer ring assembly is mounted on the roll neck.
- The reconditioned roll neck should be within acceptable limits for size and taper (see tables 15 and 16).
- All roll neck surfaces should be dimensional checked and validated for conformity against the roll neck detail drawing for proper mounting, sealing and lubrication.

The inner ring is dismantled only if the bearing raceway becomes damaged beyond repair. If the inner ring is dismantled, the roll neck may require to be reground prior to mounting a new inner ring. In this case, the roll neck dimension after grinding should allow minimum recommended tight fit, once the bearing inner ring is mounted.

SHIM OR GASKET SELECTION FOR CHOCK END COVER

Axially clamp the outer bearing rings to prevent outer ring rotation in the chock. This happens by selecting either a compressible gasket made from a material such as cork, a solid shim pack, or peelable shims between the end cover flange and chock face (fig. 242).

Whatever the bearing type, use the procedure below to determine the appropriate shim pack or gasket width:

- Adjust the cover without any gasket or shims using four equidistant bolts slightly tightened. The torque (referred to as “finger tight”) should be small enough to avoid deflecting the bearings and the cover, while allowing the cover extension to mate with the cup back face. If an exact torque value is needed, please consult with your Timken engineer.
- Rotate the bearing assembly while tightening the bolts.
- Measure the gap between the cover and chock faces at four locations close to the bolts and determine the average gap value.

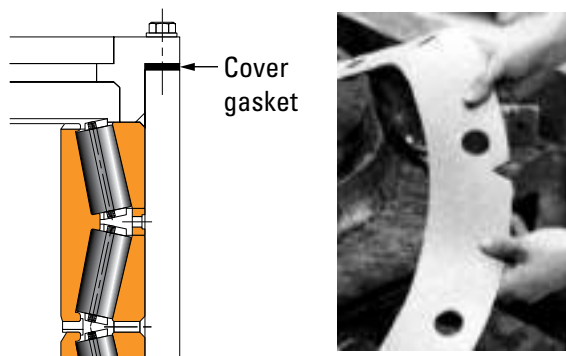

Fig. 242. Chock and cover gasket.

Using a compressible gasket:

1. Select a compressible gasket having a width equal to the measured gap, plus 15 percent to account for compression (for cork gaskets, allow 35 percent for compression).
2. Make four notches at 90 degrees to be able to re-measure the initial gap after installation (fig. 242).
3. Fit the gasket and cover.
4. Tighten the bolts while measuring the gap until you obtain the initially measured gap value.
5. If harder or softer materials are used, the above mentioned percentage will have to be adjusted accordingly.

Using a shim pack or peelable shims:

1. Select a shim pack equal to the measured gap minus 0.050 mm (0.002 in.) for positive compression.
2. Fit the shim pack and cover.
3. Using a torque wrench, tighten the bolts alternatively to the specified torque value.

NOTE

The compressible gasket thickness or the peelable shim thickness defined for a bearing and chock during assembly should not be used for another bearing assembly because of the overall width variation that will affect the cover gap distance and may result in un-clamped mounting.

BOLT TORQUE SPECIFICATION

The final bolt torque value must follow the mill builder's suggestions according to loading conditions of the particular application. The number of bolts, their size and steel grade together with their position on the covers are inputs in selection of the torque to apply to each bolt. The total axial force acting on the cover must be greater than the sum of the axial loads in the mill. For tapered roller bearings, the induced axial loads also must be taken into consideration. Please consult with your Timken engineer, if there is a need to validate the final bolt torque value.

MOUNTING AND DISMOUNTING ROLL NECK BEARINGS

FOUR-ROW TAPERED ROLLER BEARINGS WITH CYLINDRICAL BORE

Four-row tapered roller bearings are available in both TQOW and 2TDIW versions.

Whatever the position of the bearing in the mill stand arrangement, the cups must be clamped axially in the chock (see shim or gasket section on page 156 for chock end covers). Failure to provide adequate clamping across the cups leads to increased mounted internal clearance in the bearing assembly.

After fitting the chock equipped with the bearing assembly onto the roll neck, you need to set an axial gap varying from 0.25 to 1 mm (0.01 to 0.04 in.) depending on the bearing size, between the cone face and the mating component. This gap prevents wear to the cone faces as they creep on the roll neck. It also allows minor float to take place through the loose fit of the cones.

A common approach involves using a retaining nut (fig. 243). The nut features a certain number of slots on its periphery for suitable locking and positioning. The number of slots corresponds to twice the pitch, in millimeters, which allows you to achieve the required axial clearance with just one slot on the threaded and keyed retaining ring. Then use a locking key to prevent the nut from rotating. The procedure consists of tightening the nut to axially lock the system and then loosening the nut by a fraction of a revolution corresponding to the desired axial gap, considering the thread pitch, and finally securing the nut.

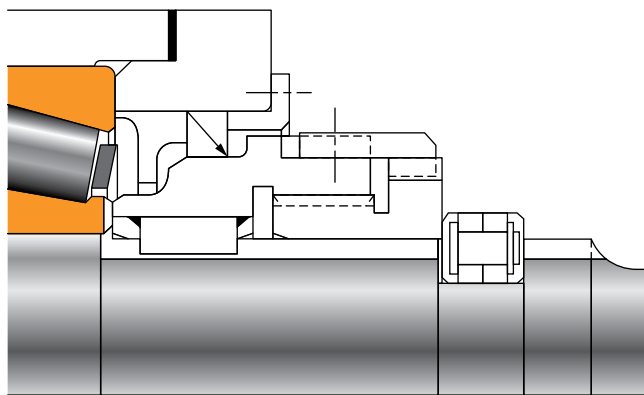

Fig. 243. Common retaining nut design.

Another type of arrangement eliminates the threaded components (fig. 244). By maintaining tighter tolerances on the bearing width and on the surrounding components, it helps to establish the required axial gap as a result of the tolerance stack without any further adjustment procedure.

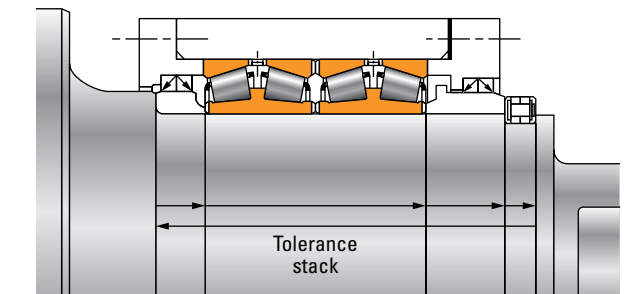

Fig. 244. Non-adjustable retaining design.

Another advantage of this retaining method is that the roll neck total length is reduced and its design considerably simplified compared to the threaded nut solution. A Timken performance code needs to be specified to ensure reduced total bearing width tolerance.

Slots are generally provided in the cone front faces (TQOW and 2TDIW types) to allow lubrication of the roll neck surface, bearing bore and the cones front faces. In cases where slots do not exist on the cone face (TQO type), these slots should be in the intermediate ring and the fillet ring faces. These faces generally have a hardness of approximately 55 to 60 HRC in order to prevent excessive wear.

Remove the chock and bearing assembly as a complete unit from the neck by unlocking and removing the retaining device. Transfer this unit from one roll to another while protecting the rolling elements and preventing any possible bearing contamination.

BEARING LUBRICATION AT MOUNTING

When using grease to lubricate the bearings, pack components containing roller sets with grease as they are assembled into the chock. Evenly weigh and distribute the correct amount of grease needed to lubricate the assemblies between the rows. Fill the gap between each roller with grease. Add additional grease through the regular fittings after the bearing is completely assembled into the chock. Figs. 245 and 246 show lubrication of a tapered roller bearing, double cone and roller components. Cylindrical roller bearing outer rings and roller assemblies are lubricated with grease at mounting time.



Fig. 245. Lubricating a tapered roller bearing with grease.



Fig. 246. Installing a greased component in the chock.

If using circulating oil, air-oil or oil-mist lubrication, put a light coating of oil on the components as they are assembled. Add additional oil to meet the required oil level after setting the chock upright.

BEARING INSTALLATION IN THE CHOCK

When stacking a bearing assembly, follow the proper sequence so that the bearing has the correct setting. Follow the components' letter marking, as discussed earlier in this chapter on page 144. When installing in the chock, you can stack a bearing assembly with either the first letter end or the last letter end down at the bottom of the chock (axis vertical), while maintaining the needed component sequence. Also, align load zone markings with each other and position them appropriately in the chock with respect to the passline.

Fig. 247 shows the typical steps of a TQOW bearing installation into the chock (2TDIW is similar):

1. The stacking sequence begins with the A side down. Install into the chock bore the AB cup, the AC double cone, the B cup spacer, the BD cup, the C cone spacer and the D cup spacer.

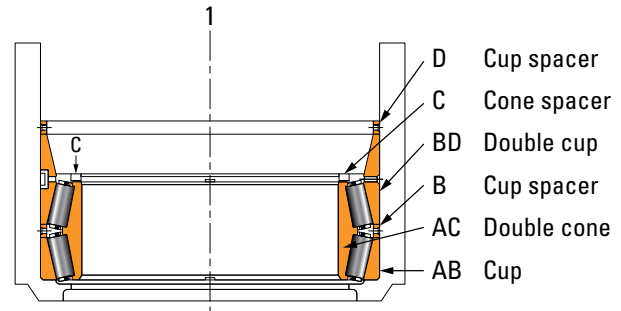

2. Install the CE double cone.

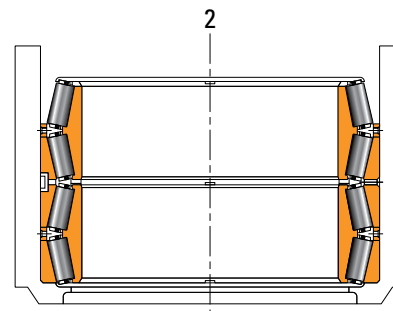

3. Install the DE cup.

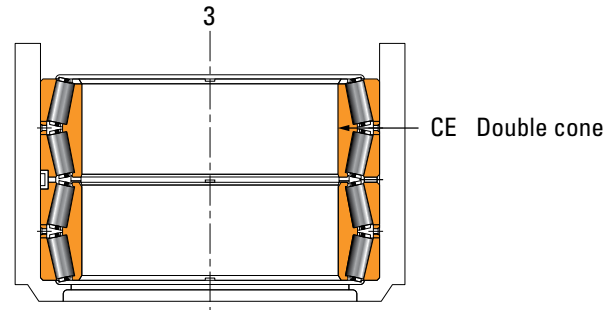

4. Select the shim or gasket width to achieve clamping across the outer rings. Torque the end cover bolts to the original equipment manufacturers' specifications.

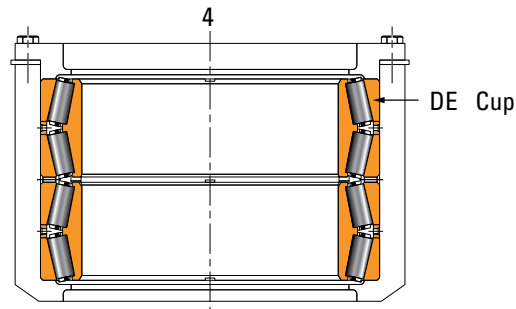

Figs. 247. TQOW assembly sequence.

Stand chock up (axis horizontal) and cover it for protection if you don't immediately assemble it onto the roll neck.

ROLL NECK MOUNTING PROCEDURE

Thoroughly clean and coat the roll neck with lubricant to facilitate installation and prevent scuffing and wear in operation.

Carefully align the chock and bearing assembly with the roll neck, making sure that the chock is square to the roll neck and the cone bores are centered. Use a guiding sleeve to avoid roll neck indentations.

Slowly move the chock onto the roll neck and continue sliding until it is completely onto the roll neck. Install the retaining device or thrust bearing to locate the chock and bearing assembly.

Take care to avoid damage to the seals during chock assembly installation. Using chocking machines can assist in ensuring a fast and correct chock assembly installation. A well-designed machine will maintain chock alignment with the roll center or the bearing journal by rotating the roll during assembly.

DISMOUNTING THE CHOCK AND BEARING ASSEMBLY

Support the roll assembly on the roll body outside diameter so that the chocks can move freely. Install the lifting devices on the chock and ensure it is secured. Remove the split-hinged ring if you use such a device.

Slide the chock and bearing assembly out from the neck. Orientate the chock with the axis vertical, then dismount the bearing in the reverse sequence used for mounting as illustrated in fig. 247 (previous page).

FOUR-ROW TQITS WITH TAPERED BORE

Fig. 248 shows a TQITS four-row bearing mounted on a roll neck. The cups of this bearing type are only clamped on the fixed or operating side. On the floating or drive side, the cups float axially in the chock bore due to clearances between the cup and the cover faces. The drive side is not only permitted to float through the cups of the bearing, but also through the chocks in the mill frame window. This arrangement permits free expansion and contraction of the roll caused by variations in roll temperatures.

The cones are mounted on a 1:12 tapered neck and pushed up against a correctly sized fillet ring and retained through a suitable clamping system. A clean, dry roll neck is required to maintain maximum holding power of the interference fit between cone and neck. The sized fillet ring will provide the correct interference fit between the cone and the roll neck. As the cone bores are ground to a tolerance typically less than 0.008 mm (0.0003 in.), all bearings are interchangeable on all roll necks.

A tight fit is applied that corresponds to a contact pressure of approximately 15 MPa (2175 psi) for the inner cone, which has the smallest section. To reduce the push-up force required to press the three cones together, we suggest a stepped tight fit reducing the tight fit for both the double center cone and the heavy-section outboard cone because of their larger sections.

This practice allows a uniform contact pressure for all the cones and reduces the necessary push-up force by approximately 20 percent.

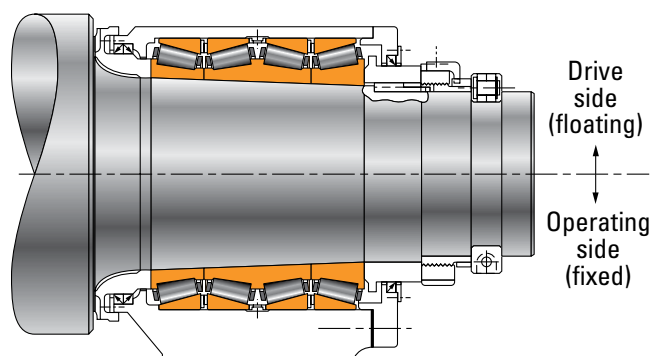

Fig. 248. Typical TQITS roll neck assembly.

MEASURING TOOLS FOR TAPERED ROLL NECKS

We will assist original equipment mill designers and mill operators in procuring and using measuring tools required for tapered roll necks. Typical designs have been proven on many mill designs (fig. 249).

Sine bar for roll neck taper and size checking

The sine bar permits the roll neck taper and size to be checked using a conventional O.D. micrometer. Check the taper of the neck by taking micrometer readings at both ends of the sine bar and comparing them (fig. 249).

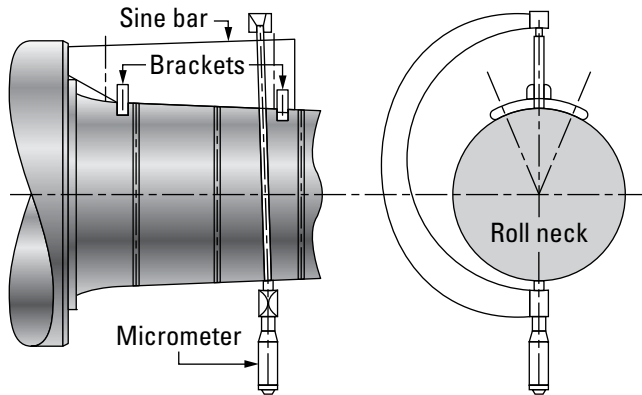

Fig. 249. Sine bar installed on roll neck.

Ring gage for fillet ring length definition

Fig. 250 illustrates the tight-fitted fillet ring in place (against the barrel face). To determine its length (L) for the particular neck on which it will be fitted, use a ring gage. We can supply this tool on request.

$$L = A - X$$

where:

L = Fillet ring length

A = Measured dimension between face of roll barrel and ring gage

X = Fixed dimension etched on ring gage flange

Y = Fixed dimension etched on O.D. of ring gage body

In the case where the extended cone version is used (TQITSE) and the bearing assembly is directly in contact with the barrel face, the above tool is not necessary. It could be used to check whether the roll neck has been correctly sized.

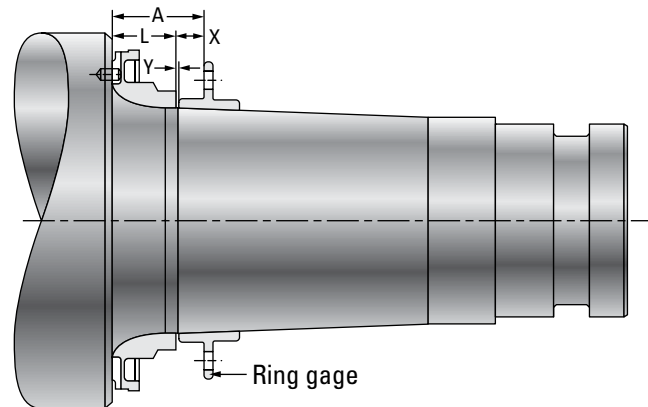

Fig. 250. Ring gage positioned on roll neck.

MOUNTING PROCEDURES FOR TQITS BEARINGS

Consider different mounting procedures to mount a four-row tapered bore bearing on the roll neck after having been previously fitted in its chock. Fig. 251 illustrates the hydraulic ring jack method.

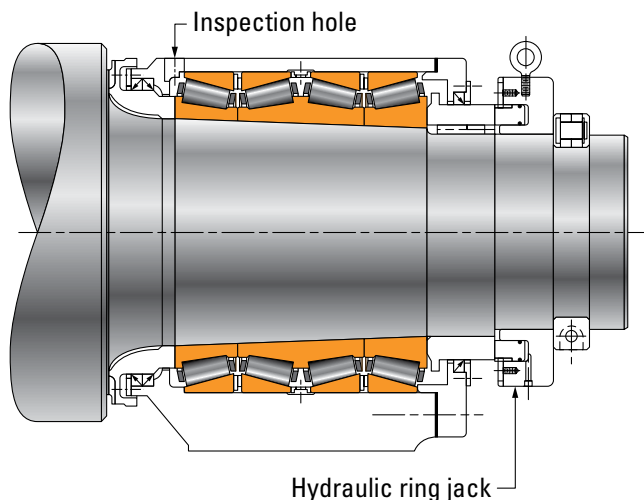

Fig. 251. Mounting TQITS with hydraulic ring jack.

Installation of TQITS bearing using a hydraulic ring jack is described below.

1. Remove all oil and/or grease from the surface of the roll neck and cone bore. This ensures that there is no lubricant leakage from the bearing during this operation.
2. Assemble the bearing and chock on the roll neck.
3. Assemble the hydraulic ring jack in place. The piston of the ring jack must be fully retracted.
4. Assemble the split-hinged ring in the groove on the neck.
5. Apply hydraulic pressure to the hydraulic jack with a suitable hydraulic pump. Take care to ensure that the pressure used to mount the bearing does not exceed the shear stress limit of the split-hinged ring backing shoulder. Push-up pressure is normally between 30 to 40 MPa (4400 and 5800 psi).
6. Using a feeler gage, check through the inspection hole to ensure that the cones are seated against the fillet ring or against the roll shoulder for the extended cone version.
7. Plug the tapped inspection hole after ensuring that the cone is tight against the fillet ring.
8. Release the pressure and back off the piston.
9. Remove the split-hinged ring.
10. Remove the hydraulic jack.
11. Install the appropriate clamping device.
12. Reinstall the split-hinged ring.

13. Clamp the bearing assembly tightly in place and lock to the next tightest position. The clamping device must be positively clamped to maintain the tight fit obtained with the hydraulic jack.

DISMOUNTING PROCEDURES FOR TQITS BEARINGS

Disassemble the TQITS tapered bore bearings mounted on the roll neck by using an oil-pressure system. The system requires one or three axial holes and radial holes leading to grooves under the outboard, central and inboard bearing cones. Find these radial holes and oil grooves around the neck's outside diameter at the approximate neutral pressure zone for each cone section (fig. 252).

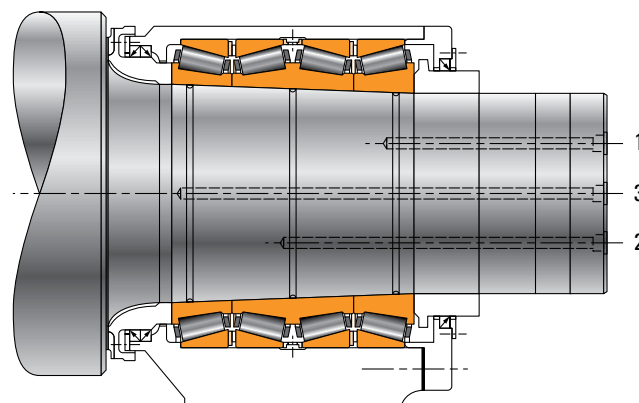

Fig. 252. Roll neck axial holes for TQITS dismounting.

You don't need to loosen the front chock cover screws when removing the bearing and chock assemblies from the roll neck.

FOUR-ROW CYLINDRICAL ROLLER BEARINGS

Four-row cylindrical roller bearings are engineered for roll-neck backup positions in flat product mills and work roll positions in long product and structural mills. They are available in three most commonly used configurations: type RY, RYL and RX.

The cylindrical bearings used in backup and work rolls are mounted with tight fit inner rings on the neck. The inner ring always determines the internal radial clearance. Inner rings of work rolls are provided in a finished state with no additional grinding required. Backup roll inner rings also can be provided in a semi-finished condition with appropriate grind stock to allow mill operators to optimize the roll's precision by finish grinding the inner ring after mounting it onto the roll neck. The part numbers for these semi-finished and inner ring and bearing assemblies are identified by a CF suffix.

TIGHT INNER RINGS FITTING PROCEDURE

Fitting procedure

The following procedure describes the step-by-step approach to achieve the fitting operation of inner rings.

1. Clean and dry roll neck and inner ring bores, as well as the roll neck shoulders and inner ring faces. Shoulders and fillet rings must be square and free of nicks. The roll neck diameter size must be carefully controlled before installing the inner rings to make sure that you achieve the proper interference.
2. Thermally expand the bearing inner ring by heating it to a maximum of 120° C (248° F) with temperature control, using an oil bath, an induction heating system or a dry oven.

NOTE

Never allow the bearing component to be in direct contact with the heating source or use a flame on the bearing.



WARNING
Failure to follow these cautions could create a risk of injury.

Remove oil or rust inhibitor from parts before heating to avoid fire and fumes.

3. Once you reach the target temperature, slide the inboard inner ring onto the roll neck using appropriate and safe tools.
4. Keep the inner ring in contact with the backing shoulder during the cooling period. The inner ring must be continually axially clamped to make sure it remains seated against the roll neck shoulder.
5. Remove the clamping devices and repeat the operation for the next inner ring, once the inboard inner ring cools to the ambient temperature.

Customer finished grinding (CF) of inner rings

When you receive bearing assemblies with semi-finished ground inner ring races (CF clearance), you obtain the final bearing radial internal clearance (RIC) by grinding the tight-mounted inner ring races on the roll neck.

After finish grinding, check the inner rings for size and geometry while meeting the following requirements:

- Inner ring O.D. final size range (refer to the respective bearing drawing). No hollow profile, lobing or visual chatter.
- Max 0.025 mm (0.001 in.) taper O.D. across inner ring width.
- No grind injury, burns or tears.
- Surface finish = 0.4 µm (16 µin.) maximum.

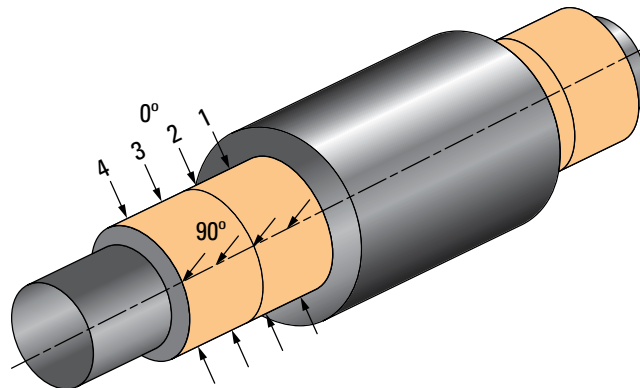

Fig. 253. Measuring points on inner ring.

Check the ground inner races O.D. size by measuring twice 90 degrees apart at four different locations along a ring (see fig. 253). Record your findings.

After grinding, oil and protect the roll neck to avoid rust and handling damage.

Dismounting of inner rings

You can remove inner rings by using a customized induction heating device, such as the Timken® EcoPower™ Induction Heater (page 131). When the inner rings heat up to the suggested temperature, use a withdrawal device to help pull the rings off the roll neck.

MOUNTING THE OUTER RING AND ROLLER ASSEMBLY INTO THE CHOCK

All ring components have a serial number marked on their faces, along with a letter to indicate the stacking sequence during installation into the chock. The four outer-races have a load zone marking from one to four, at 90-degree intervals. A line on the outside diameter indicates load zone one. Each roller set is matched to a specific outer raceway and must be maintained in that location to obtain the mounted radial clearance.

Before installing the outer ring of the bearing, thoroughly clean the chock including any lubrication ports. Remove burrs, chips and dust to prevent them from contaminating the bearing. Properly level the chock, with its axis oriented vertically to allow the bearing components to be lowered into the chock.

Fig. 254 (next page) shows the typical steps of a 4-row cylindrical outer ring and roller assembly mounting into the chock.

Bearing mounting into chock

1. Decide the stacking sequence, either A or D face down. In the following procedure we will start with the A face down. Install the A flange ring into the chock bore.

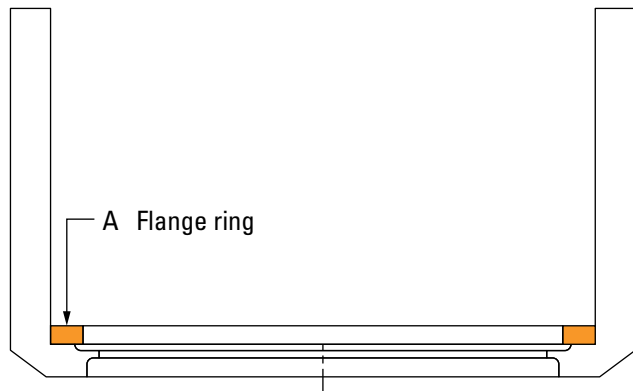

2. Install the AB outer ring with the A and B cage and roller sets matching the raceways.

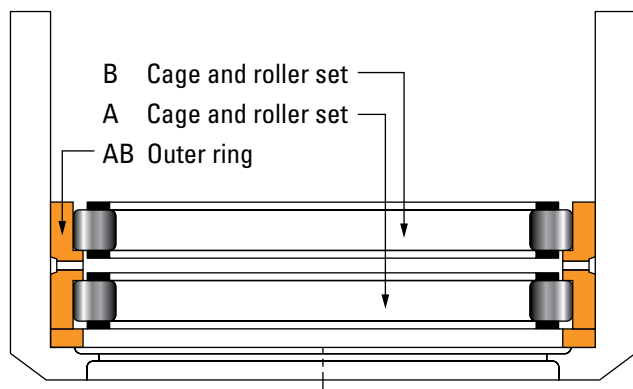

3. Install the spacer ring.

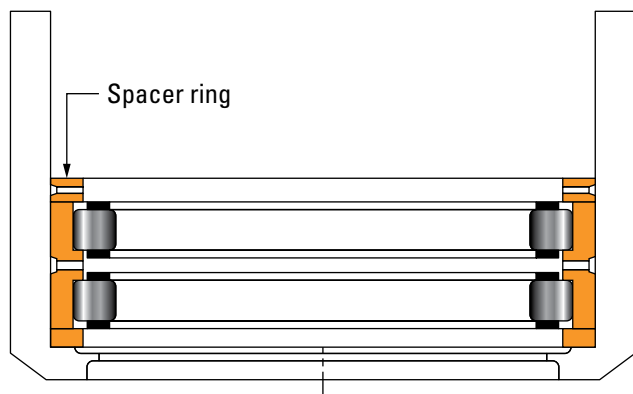

4. Install the CD outer ring with the C and D cage and roller sets matching the right raceway.

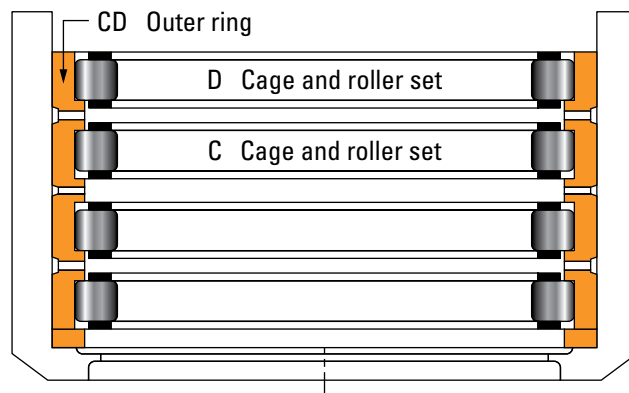

5. Install the D flange ring into the chock bore.

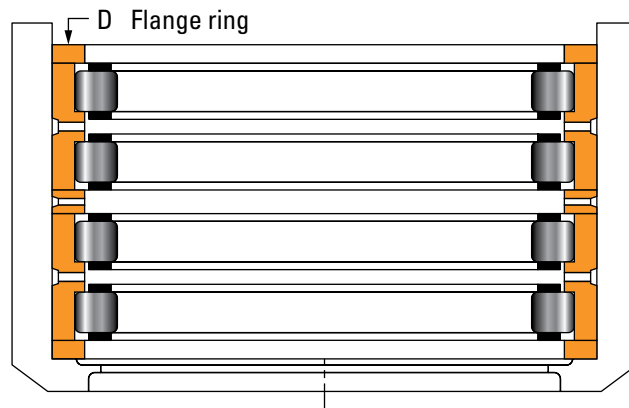

6. Select the shim or compressible gasket width to achieve clamping across the outer rings. Torque the end cover bolts to the original equipment manufacturer's specifications.

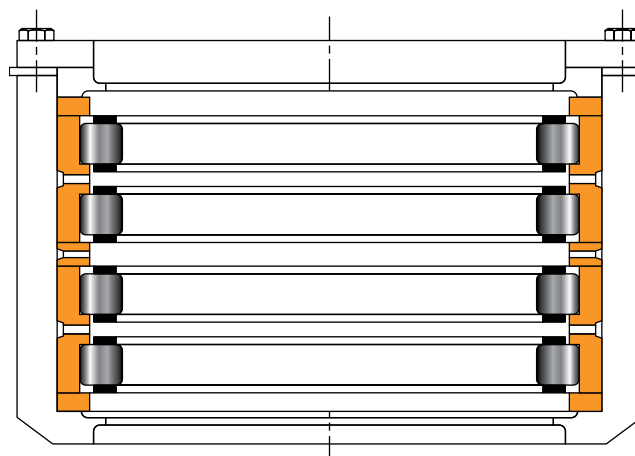

Fig. 254. Four-row cylindrical roller bearing assembly sequence.

ROLL NECK MOUNTING PROCEDURE FOR FOUR-ROW CYLINDRICAL ROLLER BEARINGS

Carefully align the chock with the roll neck inner ring assemblies, making sure that the chock is square and centered to the roll neck. Use a guiding sleeve to avoid damage from roller-to-inner-race contact during mounting. Slowly move the chock onto the roll neck (fig. 255) and continue sliding the chock until it is completely in location. Take care to avoid damaging the seals during installation. Using chocking machines can facilitate the installation. A well-designed machine will maintain chock alignment with the roll axis by rotating the roll during assembly. Install the retaining device to locate the bearing and chock assembly.

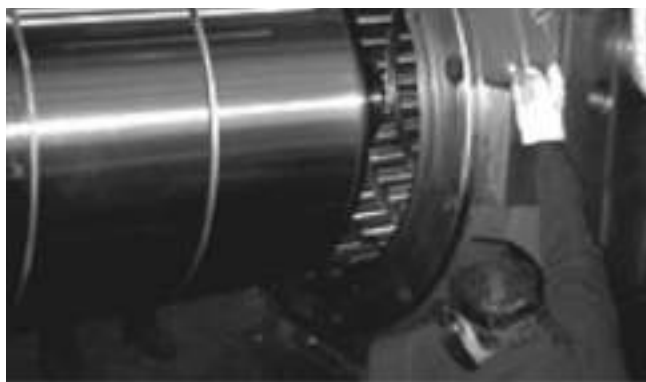

Fig. 255. Installing chock assembly onto roll neck and inner ring.

AXIAL POSITION

In most cases, when four-row tapered roller bearings are used on work rolls, no additional axial positions are required. When systems like axial shift or roll crossing are employed, the thrust loads might be so high that you may need an additional thrust bearing to ensure proper roll support. For cylindrical roll neck bearings, such axial positions are mandatory on the fixed side.

TWO-ROW TDIK

Fig. 256 shows a two-row TDIK tapered roller bearing used at the axial position of the roll neck. This thrust position is located at the fixed operator side and used in combination with a radial four-row tapered roller bearing on work rolls and flat mill intermediate rolls or adjacent to a hydrodynamic bearing or four-row cylindrical bearing assembly on the backup rolls.

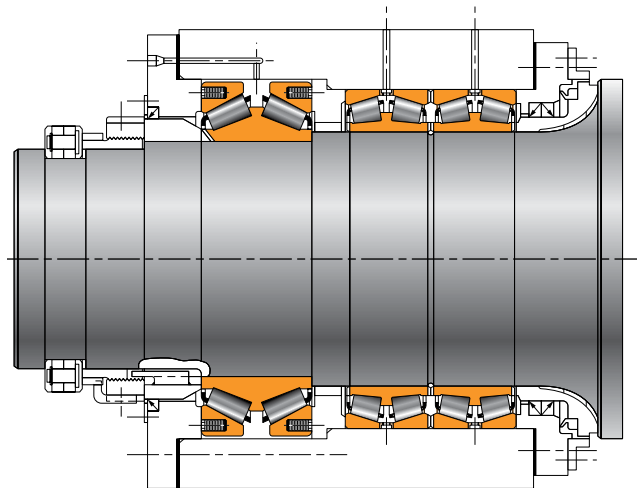

Fig. 256. Typical TDIK and TQOW bearing arrangement.

We suggest using the TDIK assembly with a spring system to seat the unloaded cup on its set of rollers to minimize roller skewing (fig. 257). You achieve and control the spring stroke by using metal shims between the flange and the housing. The spring system then develops the correct axial force that will seat the unloaded row.

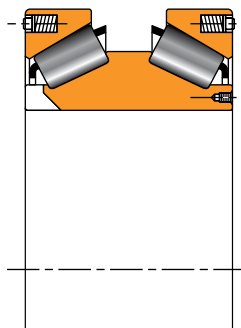

Fig. 257. TDIK with spring system.

Sometimes a spacer-preset TDIK assembly mounted into a carrier is used instead of the spring system incorporated in the cups. In both cases the mounting is similar.

A keyway is provided in the cone to prevent the cone from rotating. Keyways in the cups also are occasionally provided (example: reversing mills). If you use this solution, the key and keyway alignment needs to be ensured at the mounting stage.

TWO-ROW TDIK MOUNTING PROCEDURE

The following provides a detailed procedure on mounting the bearing assemblies with incorporated springs (fig. 258):

Step 1. Record the measured width across the cups (Dim1). We include this information with the measuring sheet provided with the bearing assembly. The installer also can measure it (if wear has occurred). If you measure Dim1, apply the appropriate axial load and take the bearing rotation to ensure that the roller sets are correctly loaded against the double cone central rib.

Step 2. Measure and record the depth of the chock bore from the front face to the housing shoulder (Dim2).

Step 3. Measure and record the length of the chock cover's spigot that extends into the chock bore (Dim3). From steps one to three, calculate the required shim thickness using the following equation:

$$\text{Required shim thickness} = \text{Dim1} + \text{Dim3} - \text{Dim2} + (0.40 \pm 0.05 \text{ mm} [0.016 \pm 0.002 \text{ in.}])$$

Step 4. Install the metal shim between the chock and cover. Rotate the cone to ensure proper seating of the rollers against the large rib. Tighten the bolts alternately and progressively to original equipment manufacturer's suggested torque value for proper clamp up. The springs (internal to the bearing) will be compressed equally on each side of the bearing, so the gap is equally measured between the cup back face and adjacent shoulder.

The bearing is now set up in light preload prior to mounting on the roll. Measure the gap between the cup back face and shoulder face with a feeler gage. If the measurement falls outside the specified range, adjust the shim thickness to achieve a gap measurement within the range.

For bearing assemblies with incorporated springs in the chock, follow a similar procedure as the one used above for incorporated springs bearings. In this case, the total width across the cup back faces is not provided and must be measured at mounting time.

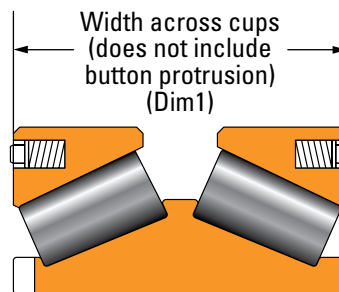

Step 1.

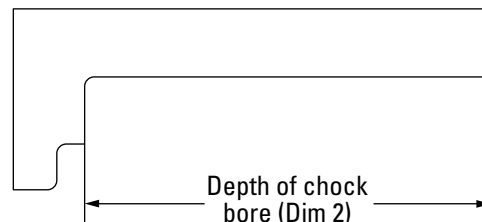

Step 2.

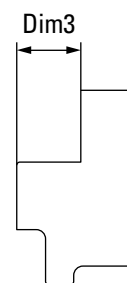

Step 3.

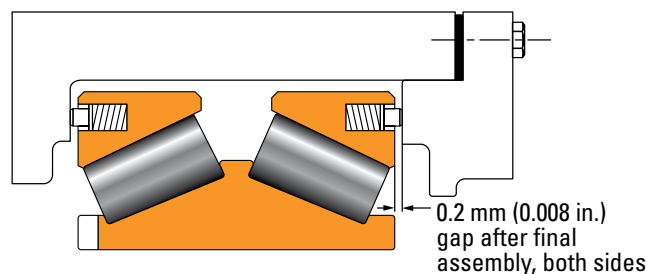

Step 4.

Fig. 258. TDIK assembly sequence.

TWO-ROW TTDWK/TTDFLK MOUNTING PROCEDURE

The TTDWK double-acting thrust bearing offers higher axial ratings than the TDIK-type bearing. It is an alternative choice for anticipated high axial loads.

This TTDWK double-acting thrust bearing always is mounted in combination with a radial bearing at the fixed position (fig. 259).

Such an assembly is fitted in a separate housing that will be mounted on the chock.

The outer races are not axially clamped, but adjusted to obtain the required axial clearance, allowing the springs to develop the correct axial force to seat the unloaded row. A keyway is generally provided in the center double-race ring to stop it from rotating on the roll neck.

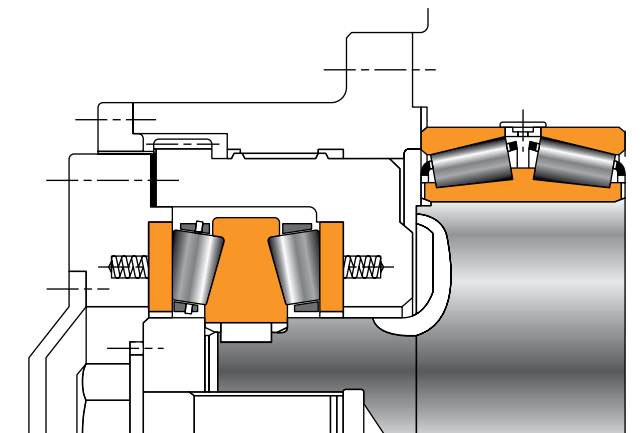

Fig. 259. Typical TTDWK thrust bearing arrangement.

Fig. 260 shows a different axial bearing type – TTDFLK. It features a flat central ring and an outer spacer. The bearing is preset and does not require adjustment during mounting. If the bearing is supplied without a spacer, then the same spring arrangement and adjustment as the TTDWK must be used.

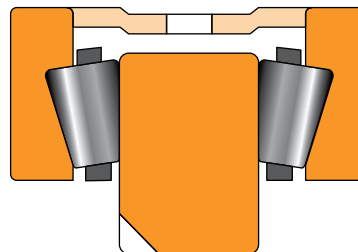

Fig. 260. TTDFLK thrust bearing.

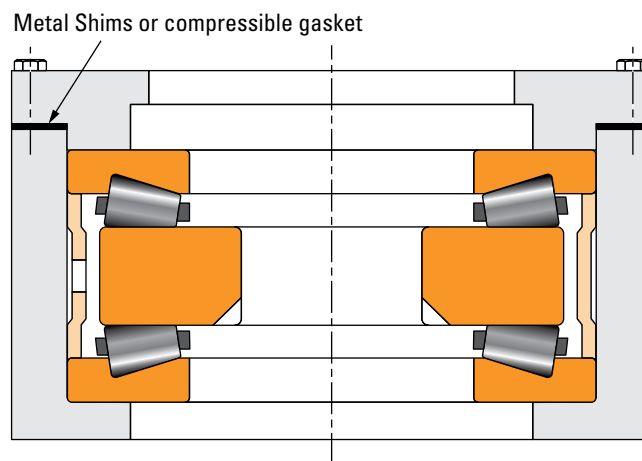

Fig. 261. TTDFLK thrust bearing mounted in housing.

You must axially clamp the assembly using metal shims or a compressible gasket following the same procedure for radial bearings (fig. 261). You also can order this bearing without the spacer and then mount it like the TTDWK (fig. 259).

You can only install these double-acting bearings (TTDWK and TTDFLK) as a unit. Take care to ensure that the flat races are correctly centered when lifting or lowering this bearing into the housing.

THRUST SPHERICAL MOUNTING PROCEDURE

Thrust spherical roller bearings also are used at axial positions on long product mill, flat product, cold mill work or intermediate rolls with axial shifting. To support axial loads in both directions, the spherical thrust bearings are mounted in pairs back to back. A spring system maintains the outer races in contact with the rollers on the unloaded row. You need to establish an axial clearance at mounting time using a shim pack between the chock and the cover, in a similar manner to the TDIK.

A cartridge sometimes is used with the inner rings tight fitted on a sleeve and the sleeve loose fitted and keyed on the shaft (see fig. 262).

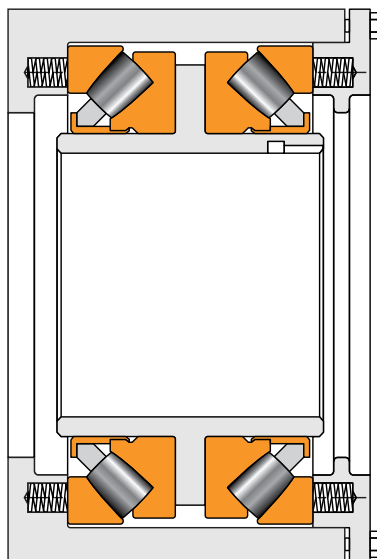

Fig. 262. Two TSR assemblies on a sleeve.

TAPERED THRUST BEARING MOUNTING PROCEDURE FOR SCREWDOWN SYSTEMS

The bearings used in screwdown systems include single row tapered thrust designs that are available in a variety of configurations (see pages 56-57 for further details). The heavy-duty thrust bearing makes the connection between the screwdown and the top roll chock, as shown in fig. 263.

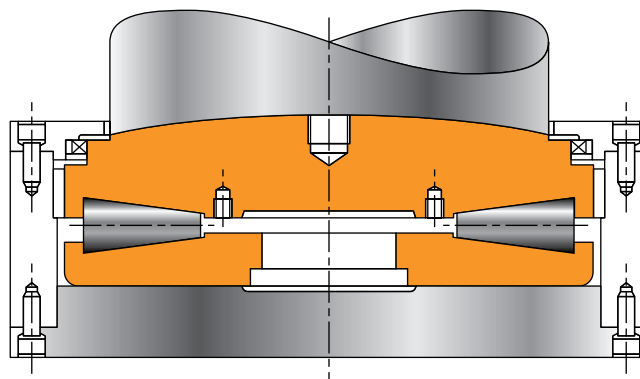

Fig. 263. Typical screwdown support configuration using a TTHDSX thrust bearing.

These bearings are assembled into a housing or cartridge. Follow these steps when installing these assemblies:

1. Prepare the housing, retaining and sealing plates, thrust bearing races and roller components for mounting.
2. Place the lower race in the housing using a lifting tool.
3. Place the rollers on the lower race, one by one, making sure that the rollers do not damage the raceway. Align all lightly greased or oiled rollers into a full circle on the lower race, ensuring that the circle is concentric with the inner ring and the rollers are in contact.
4. Slowly lower the top race onto the rollers. Use caution to ensure correct mounting and avoid a roller being trapped out of position between the lower and upper races which would result in bruises on roller body or raceways.
5. Rotate the assembly slowly by hand to ensure free movement.
6. Mount the upper retaining and sealing plate.
7. Fill the housing with a high quality extreme pressure (EP) oil having a viscosity of approximately 460 cSt at 40° C.

When you finish the maintenance, follow the dismounting steps in the reverse order. Pay particular attention to avoid accidents due to rollers falling out of the housing during dismounting.

AUXILIARY EQUIPMENT AND OTHER BEARING TYPE MOUNTING PROCEDURES

For industry-standard bearing types, please refer to the following Timken catalogs for mounting procedures: Timken Tapered Roller Bearing Catalog (order no. 10481), Timken Cylindrical Roller Bearing Catalog (order no. 10447), Timken Spherical Roller Bearing Catalog (order no. 10446) and the Timken Engineering Manual (order no. 10424).

BEARING SETTING TECHNIQUES

Depending on the application's running conditions and the bearing type, a bearing operates with an internal clearance (end play) or preload defined either radially or axially. The clearance or preload is referred to as bearing setting.

ADJUSTABLE AND NON-ADJUSTABLE BEARINGS

ADJUSTABLE BEARINGS

We consider the following three types of bearings as adjustable:

- Tapered roller bearings.
- Angular-contact ball bearings.
- Spherical thrust bearings.

The above bearing types feature separable races that can be moved one relative to another. This modifies the clearance and obtains the right setting in a system of two interdependent bearings. For these styles of bearings, the clearance in the system is measured axially along the bearing centerline.

Built-in internal clearance from the factory is not applicable on this type of single-row bearing, as clearance is adjusted at the time of assembly. For multi-row assemblies, a spacer or a specific internal bearing component allows the bearing to be supplied as a preset assembly with a certain amount of axial endplay or axial preload. The vast majority of adjustable bearings used in the metals industry come with axial endplay. In specific cases, the bearings come with axial preload.

NON-ADJUSTABLE BEARINGS

With the exception of certain versions of cylindrical roller bearings, these bearing types have non-separable rings. They come as a unit with a certain amount of internal clearance from the factory called RIC. You can't adjust the clearance at mounting unless a separate tapered sleeve is designed into the application.

The following lists the five different types of bearings considered non-adjustable:

- Radial ball bearings, also called deep-groove ball bearings.
- Spherical roller bearings.
- Cylindrical roller bearings.
- ADAPT™ roller bearings.
- Needle roller bearings.

Built-in RIC, as supplied from the factory, conforms to International Standards Organization or ABMA standards and is classified in an increasing order from C2 to C5.

C2	Less than normal
--	Normal (C0 or CN not mentioned in the part number)
C3	Greater than C0
C4	Greater than C3
C5	Greater than C4

Special C clearances (e.g C6, C7, etc.) are bearing-specific.

The alpha-numeric combination in the part number indicates the RIC (ex: 23052YMBW507C3), except for C0 RIC, which is not designated.

Clearances differ between straight bore versus tapered bore bearings of same product family series for a given standardized clearance. Factory RIC is reduced during assembly due to the amount of tight fit between the inner race and the shaft and between the outer race and housing.

MULTI-ROW TAPERED ROLLER BEARING SETTING

BEARING BENCH ENDPLAY (BEP)

Most multi-row tapered roller bearings (two-rows or more) come as preset assemblies. We achieve the setting through spacers. For Timken® tapered roller bearings, we call the bearing setting before mounting BEP. It is a factory setting of the axial clearance.

The BEP is determined at bearing assembly by Timken through measurement and matching of the bearing components. All components are marked with a serial number (see page 144).

The nominal BEP typically has a tolerance of ± 0.025 mm (± 0.001 in.) for standard class assemblies.

INFLUENCE OF FITTING ON THE BEARING SETTING (BEP)

As a general rule, the bearing rotating members are mounted with a tight fit, while stationary components are mainly loose fitted, with some exceptions based on application design specifics.

As a general rule, the bearing rotating members are mounted with a tight fit, while stationary components are mainly loose-fitted, with some exceptions based on application design specifics. Due to frequent roll neck changes, four-row tapered roller bearings used on rolling mill roll neck are the notable exception.

The straight-bore of four-row tapered roller bearings are commonly mounted with loose-mounted cones and cups. In this case, the mounted endplay (MEP) will be the same as the BEP. For any other industrial application where bearings are tight-fitted either onto the shaft and/or in the housing, the loss of endplay is determined using the relationships on page 88 and 89.

BEARING MOUNTED ENDPLAY (MEP)

During the mounting operation, the initial BEP (supplied from the factory) will be reduced due to the effect of the tight fit between the cones and the shaft, and/or between the cups and the housing. The resulting setting value is called the mounted setting or MEP.

The general relationship is:

$$\text{MEP} = \text{BEP} - \text{Loss of endplay due to tight fit}$$

Because all the parameters involved in this calculation are dimensions with tolerances (shaft O.D., housing I.D., cone bore, cup O.D., BEP), the MEP range will be a function of these tolerances.

See below for a metric example of an MEP range calculation:

Example: MEP range calculation

Bearing assembly: TDO M249749 / M249710CD / M249749XB.

Dimensions:

Bore = 256.000 mm
 O.D. = 358.775 mm
 Width = 152.400 mm
 K = 1.76
 BEP = 0.305 mm

The BEP tolerance ± 0.025 mm

FITTING PRACTICE EXAMPLE (METRIC)

Cone Bore mm	Shaft Seat mm	Cone Fit mm	Cup O.D. mm	Housing I.D. mm	Cup Fit mm
254.025	254.038	0.013 T	358.826	358.877	0.051 L
254.000	254.064	0.064 T	358.775	358.927	0.152 L

The fitting practice for this example appears in the table above.

To calculate the loss of endplay, we use the relationships from page 89.

For this example, the mean cone diameter is assumed equal to the cone backing diameter available in the catalog product tables (274 mm). Please contact your Timken engineer for an exact calculation.

The calculated range of the loss of endplay in the two row:

$$\text{Loss of endplay max.} = (1.76/0.39) \times (254/274) \times 0.064 = 0.267 \text{ mm}$$

$$\text{Loss of endplay min.} = (1.76/0.39) \times (254/274) \times 0.013 = 0.054 \text{ mm}$$

$$\begin{aligned} \text{MEPmin} &= \text{BEPmin.} - \text{Loss of endplay max} \\ &= 0.305 - 0.025 - 0.267 \\ &= 0.013 \text{ mm} \end{aligned}$$

$$\begin{aligned} \text{MEPmax} &= \text{BEPmax} - \text{Loss of endplay min.} \\ &= 0.305 + 0.025 - 0.054 \\ &= 0.276 \text{ mm} \end{aligned}$$

The MEP range will therefore be 0.013 – 0.276 mm.

NOTE

The same procedure is followed for inch dimensions.

CONTROLLING BEARING ASSEMBLY SETTING

Check multiple-row tapered roller bearings on a regular basis to determine whether or not the initial BEP needs readjustment.

TAPERED TWO-ROW ASSEMBLY MEASUREMENT

Use the drop-method procedure below to measure the BEP (fig. 264).

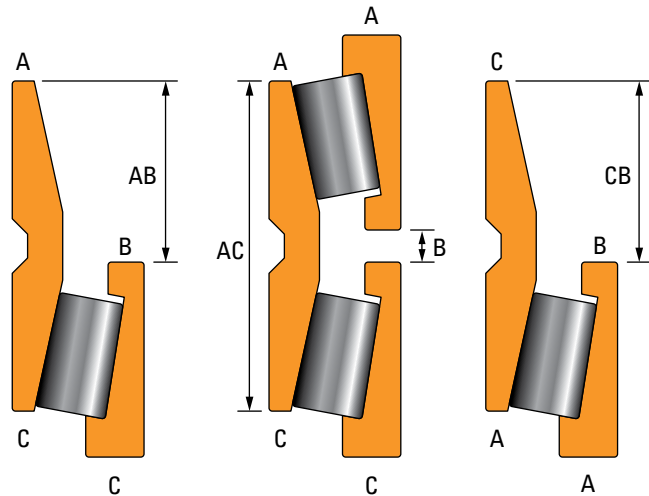

Fig. 264. Tapered two-row assembly measuring sequence.

Step 1:

- Stack the bearing components on a flat, solid surface like a bench.
- Alternately set up both cones CB and AB this way and stack the corresponding raceway of the double cup on the cone.
- After carefully rotating and oscillating the cup while applying a downward force to seat the rollers, measure the corresponding distance from small cone face to small cup face at four locations, 90 degrees apart, and the average value determined, respectively AB and CB.

Step 2:

- Measure double-cup width AC at four locations and determine the average value.
- Calculate the distance B between both small cone face (corresponding to a zero BEP spacer width):
 $B = AB + CB - AC$
- If the measurement checks the actual BEP of an existing assembly, then the actual BEP value = spacer width – B.

Use the same method to determine the spacer width when an assembly is set for a target BEP. In this case, spacer width = B + target BEP +/- BEP tolerance.

TAPERED FOUR-ROW ASSEMBLY MEASUREMENT

Check BEP on four-row bearing assemblies at least once a year (also refer to the equipment manufacturer's instructions) to determine if any wear has occurred.

For BEP measurements, stack the bearing without spacers on a flat, solid surface with the lower cup supported in a base fixture. This base fixture must be counter bored for cage clearance and allow for free rotation of the cone assembly. Add weight to the bearing being measured to properly seat the components (fig. 265).



Fig. 265. Applied weight for seating rollers.

The weight applied should be comparable to the weight of the bearing you're measuring. It also should be made to pilot on the bearing cup outside diameter and counter bored to clear the cage. Bearings with a long service life particularly need this weight since components may be out-of-round and can be difficult to seat properly. As a safety precaution, keep the chains or slings used to lift the added weight in place with slight slack at all times.

Anytime you stack up the bearing, whether for measurements (in which case the cup and cone spacers are left out) or for assembly in the chock, follow the proper stacking sequence to have the setting clearance (see fig. 266 for an example of cup marking, as well as the bearing marking section on page 144).



Fig. 266. Example of E cup marking.

Stack the bearing with either the A cup down or the E cup down, but the components must remain in sequence. After stacking the bearing, apply light oil on the raceways to help seat the rollers and to protect the bearing (fig. 267). You must rotate all the parts separately to seat the rollers.



Fig. 267. Applying light oil to rollers and race.

You may need to repeat this bearing rotation to fully seat the parts. You can easily check proper roller seating with a 0.05 mm (0.002 in.) feeler gage inserted between the large end of the rollers and the cone rib. Check all four sets of rollers for seating at four different locations.

With all the components seated, measure the B, C and D gaps at four places, 90 degrees apart around the bearing (fig. 268). Use the average of the four measurements for each gap for that specific gap.



Fig. 268. Measuring B or D gap.

Also measure the B, C and D spacers to obtain their width (fig. 269). Bearings properly set with endplay always will have a spacer width greater than the corresponding spacer gap.



Fig. 269. Measuring spacer width.

The difference between the spacer width and gap measurement in the two adjacent rows of rollers is the BEP.

TAPERED FOUR-ROW ASSEMBLY BEP READJUSTMENT

You can adjust bearing setting by regrinding each spacer width. Usually, it is not necessary to regrind the spacers until the moment the BEP increases to double the amount of the original value. In this case, you need to regrind the spacer widths to provide for 1.5 times the original bearing BEP. Keep a record of the spacer gaps and spacer widths on the roll neck bearing service record card.

Below shows a calculation example of bearing BEP readjustment.

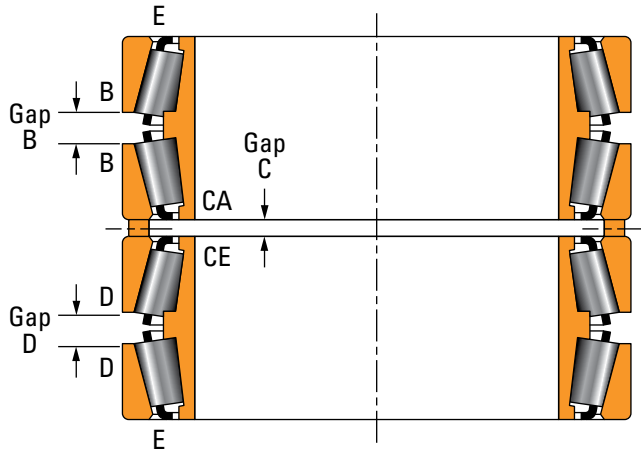

Fig. 270. B, C and D gap measurements.

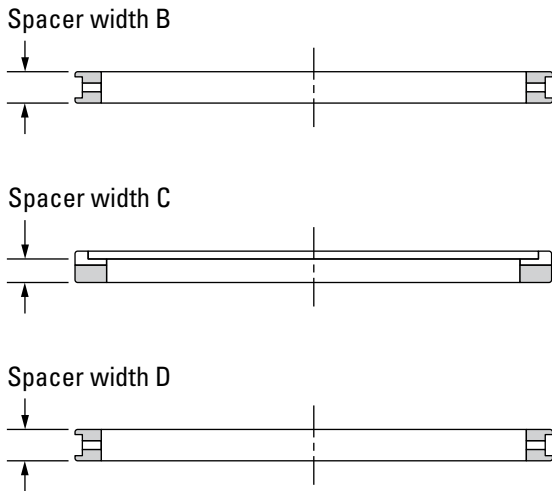

Fig. 271. B, C and D spacer width measurements.

Example:

Spacer regrind when BEP is two times the original setting.

Bearing BEP Readjustment	
BEP Reference Values	mm in.
Original BEP of the bearing (new)	0.31 0.012
Regrind spacers to provide 1.5 times original BEP	0.46 0.018
Spacers Width Calculations	
Gap measurement	26.01 1.024
Target BEP	0.46 0.018
Regrind spacer width to	26.47 1.042
All three B, C and D spacer widths are calculated using the actual values of B, C and D gap measurements plus 1.5 times the original BEP.	

CYLINDRICAL ROLLER BEARING SETTING

Four-row cylindrical bearings feature inner race assemblies that are interchangeable with outer race and roller assemblies. There is no specific matching between them. The most important parameter to ensure interchangeability is the DUR, dimension F (fig. 272) that can be found in the Timken Metals Product Tables (see table 17 for an example).

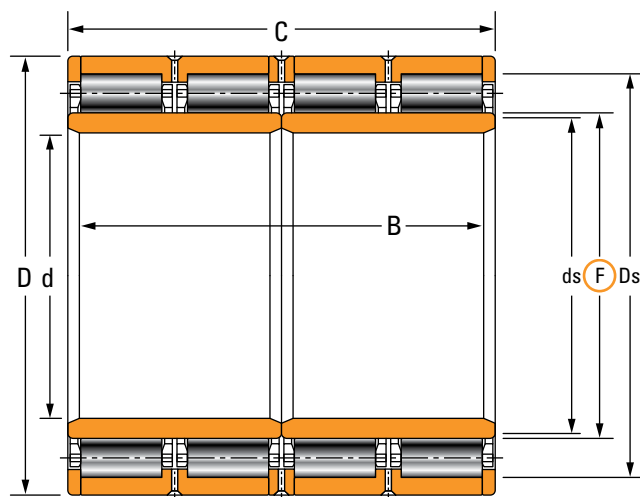

Fig. 272. DUR dimension F.

TABLE 17. DUR PRODUCT TABLE EXAMPLE

Bearing Dimensions					Load Ratings	
Bore	O.D.	Width	Width	DUR	Dynamic (1)	Static
d	D	B	C	F	C ₁	C ₀
mm in.	mm in.	mm in.	mm in.	mm in.	kN lbf.	kN lbf.
145.000 5.7087	225.000 8.8583	156.000 6.1417	156.000 6.1417	169.000 6.6535	1100 248000	1832 412000
160.000 6.2992	230.000 9.0551	130.000 5.1181	130.000 5.1181	180.000 7.0866	894 202000	1440 324000

BEARING RIC

We can supply the four-row cylindrical bearing in either of two ways related to its RIC:

- Fixed RIC range:** Examples include C0, C2, C3 and C4 suffixes. The inner rings are delivered finished to a final O.D. size range. This size range, coupled with the bearing's fixed DUR, results in the published unmounted RIC listed in our product tables. The end user or builder should consider the loss of radial clearance due to the tight fit of the inner ring when making their selection of the appropriate RIC selection to order.
- Customized mounted RIC:** Examples include CFi suffixes (where i is a numeral; ex. CF1). The inner rings possess a targeted amount of added grindstock to remove from the inner rings, after the inner rings have been mounted with an interference fit. Roll suppliers frequently perform this inner ring O.D. grind operation because it increases the mills precision by mating the inner rings O.D. to the roll body's outside diameter. Further eliminating the variable related to the interference fit of the inner rings, reduces the total range of the mounted RIC.

INFLUENCE OF BEARING FIT ON THE RIC

Four-row cylindrical roller bearing inner rings are tight fitted onto the roll neck. The amount of fit interference depends upon the size of the bearing, its type and the application on which it is used (i.e. a 4-Hi mill backup roll neck or a 2-Hi long product mill roll neck).

The tight fit will make a direct impact on the outside diameter of the ring that will elastically expand according to the formula:

$$D_2 = D_1 + \text{Diametric Increase}$$

where:

$$\begin{aligned} \text{Diametric Increase} &= \text{Loss of RIC due to tight fit} \\ &= d_1 / D_1 \times \text{tight fit} \\ &\text{and,} \\ \text{Tight fit} &= d_2 - d_1 \end{aligned}$$

Since D₁ is not a published dimension, use the DUR dimension F instead.

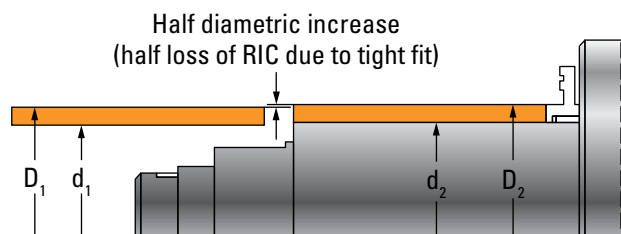

Fig. 273. Cylindrical inner ring O.D. increase after tight fit on the roll neck.

BEARING STORAGE, HANDLING AND INSTALLATION

BEARING SETTING TECHNIQUES

For finished ground inner rings, consider this diametric increase to define and calculate the resultant mounted RIC (fig. 273 previous page):

Mounted RIC = Unmounted RIC – diametric increase

The final result for the mounted RIC range will have a range equal to the sum of all radial tolerances, because all the parameters involved in this calculation are dimensions with tolerance (shaft diameter, inner ring bores, unmounted RIC).

The range for the mounted RIC acts as a function of the tolerance of the roll neck diameter, the bearing bore and the range of the unmounted RIC. The following metric example illustrates this.

Example (metric): RIC range calculation	
Bearing assembly	160RYL1467C3
Unmounted RIC	0.115 – 0.165 mm
Roll neck diameter	160.043 – 160.068 mm
Bearing bore	160.000 – 159.982 mm
Resulting fit	0.043 – 0.086 mm (Tight)
Loss of RIC	0.038 – 0.076 mm
Mounted RIC min. = Unmounted RIC min. – Loss of RIC max.	
	= 0.115 – 0.076 = 0.039 mm
Mounted RIC max. = Unmounted RIC max. – Loss of RIC min.	
	= 0.165 – 0.038 = 0.127 mm
The mounted RIC range will therefore be 0.019 – 0.107 mm.	

NOTE

The same procedure is followed for inch dimensions.

Fig. 274 shows the mounted RIC as measured with the chock freely supported on the roll neck.

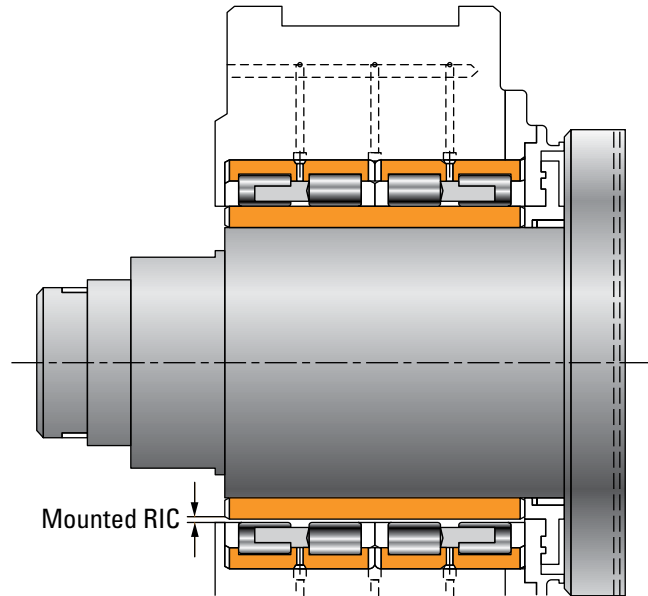

Fig. 274. Mounted radial internal clearance (RIC).

For non-ground inner rings (CF suffix), the O.D. diametric increase doesn't impact the RIC because the ring is ground after fitting on the roll neck.

SERVICES

This section outlines our service capabilities that can improve your operation:

- Gearbox repair.
- Bearing reconditioning and reclamation.
- Chock and roll upgrades.
- MILLTEC® rolling mill program.
- Service engineering.
- Training.

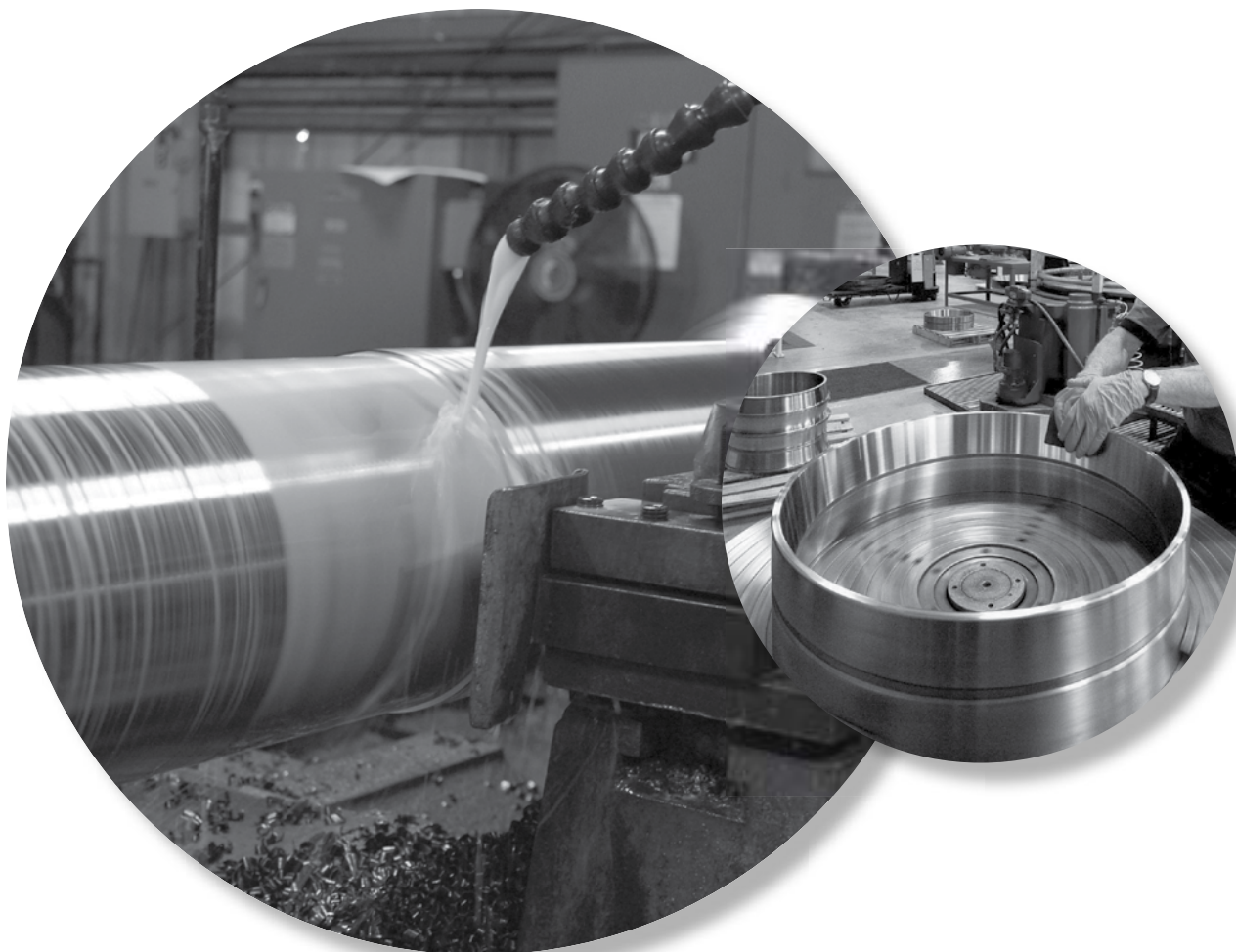

GEARBOX REPAIR

Timken repairs virtually any gearbox make and model, with on-site emergency breakdown service available if needed. Whether it's a part of a predictive maintenance routine or if your gearbox shows signs of wear (fig. 275) and increasing noise levels, it may be time for an in-depth inspection.

We offer globally recognized expertise in power transmission solutions for the world's heavy industrial markets. We have a large installed base of drives through our proprietary brands and provide mission-critical gear solutions for basic oxygen furnace (BOF) and other heavy applications in the metals industry.

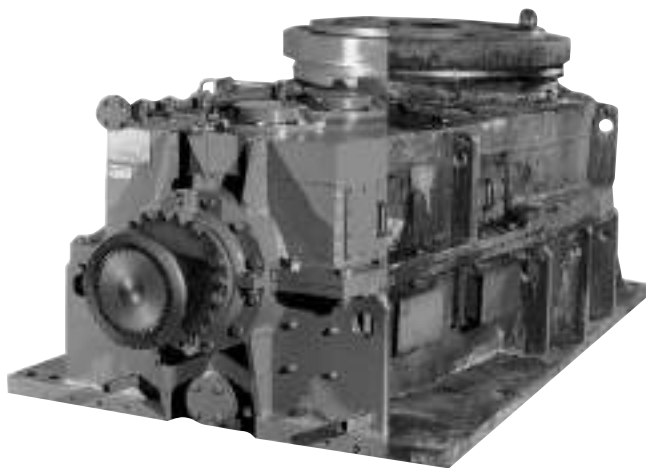

Fig. 275. Before and after gearbox repair example.

SCOPE OF WORK

Technical services available for gearbox repair include:

- Condition Monitoring
- Diagnostics
- Drive Exchange Program
- Engineered Upgrades
- GearLogicSM Preservation System
- On-site Inspection
- Predictive Maintenance
- Renewal Part Specification

Our experience includes all major gear types, bearings, hydroviscous clutches and brakes.

UPGRADE OPPORTUNITIES

LONGER GEAR LIFE THROUGH METAL HARDENING

We strengthen gears through a wide range of options available. We handle a variety of processes from relatively simple through-hardening techniques, to the more complex case-hardening, such as nitriding and carburizing. Heat treating techniques and advances in gear grinding technology make it possible to grind casehardened gears, resulting in dramatic and positive affects to the equipment's overall lifecycle.

COUPLING ANALYSIS ENSURES OPTIMUM POWER TRANSMISSION

Whether you are using gear type or grid type couplings in a standard or reverse mounted configuration, you do not have to remove them from the input or output shafts before sending your gearbox to one of our service centers for overhaul or upgrade. We suggest you leave the half couplings on the gearbox shafts so we can inspect the condition of the teeth, seals, bores and key ways. Our site engineers ensure the coupling is properly rated for the gearbox, which is very important when a gear ratio change or an upgrade to the load rating has occurred. Our service centers can upgrade the existing coupling to help ensure better efficiency.

SMART ADD-ONS REDUCE ANXIETY

Our upgrades include diagnostic instrumentation to warn against pending failure, reinforced housings to add stability, or user-friendly oil filtration systems.

With more than 120 years of design experience for critical heavy equipment in the power generation, infrastructure and military defense industries, Timken leverages our capabilities by offering world-class engineering and technical field service support for power transmission equipment. Our engineers utilize state-of-the-art inspection and measurement equipment as well as techniques that provide qualified answers to critical gear questions.

For more details, please contact your Timken engineer.

BEARING RECONDITIONING AND RECLAMATION

It is critical to lower the cost per ton rolled and achieve a higher yield to keep a metals plant competitive in today's market. One of the best ways to deliver performance is to make sure the mechanical components remain part of an integrated maintenance plan.

We offer a full range of maintenance, reconditioning and reliability services for the metals industry. Through our remanufacturing and repair operations, we can help bearings reach their full design-life potential by restoring worn and stressed materials, reducing operating costs and improving plant uptime. With our reliability products, remote monitoring and training services, we can customize your maintenance programs for maximum plant performance. Using these services can lead to improved plant efficiency and reduced overall production costs.

BEARING RECONDITIONING

Much time, effort and money goes into designing bearings for maximum service life. Unfortunately, most bearings are removed from service before they reach their full useful or economic life. When integrated into a regular mill maintenance program, bearing repair can play an important role in extending bearing life and preventing mill downtime.

Equipment that benefits the most from a bearing reconditioning program includes highly loaded applications such as continuous casting machines, rolling mill chocks (work rolls, intermediate rolls and backup rolls), mechanical screwdown units, pinion stands, gear units, tension leveling units, overhead cranes and table rolls.

We offer reconditioning services for all bearing types and brands, including non-Timken products. Our experienced engineers help you identify the type of bearing damage, determine the root cause of the problem and suggest a proper repair solution. Bearings sized from 250 mm to 2000 mm (10 to 80 in.) outside diameter (O.D.) are ideal candidates for repair. We suggest grouping bearings smaller than 250 mm (10 in.) outside diameter (O.D.) into economical quantities.

BEARING RECLAMATION

We also offer reclamation services for bearings from 76 mm to 300 mm (3 to 12 in.) bore. Reclamation can save anywhere from 20 to 70 percent off the cost of buying new.

Reclamation works for applications that use small bearings in large quantities, like continuous casters, ferrous and non-ferrous strip levelers, pallet mills and tables, transfer and conveyor rolls.

Our reclamation process begins with an initial inspection to determine the level of service required. We disassemble and clean serviceable bearings. Then we apply a polishing finish using specialized, Timken-developed processes to return bearings back to serviceable condition. We then measure, reassemble and lubricate the reclaimed bearing components before returning them to the customer with a written report.

ADVANTAGES OF RECONDITIONING AND RECLAMATION

Both our bearing reconditioning and reclamation programs provide many advantages.

- **Overall cost reduction.** Reconditioning costs considerably less compared to the cost of a new bearing.
- **Improved product quality.** A reconditioned bearing with proper clearance and endplay provides greater performance and reliability than a bearing with worn settings and materials, which cause unnecessary vibration and chatter.
- **Reduced lead times compared to buying new bearings.** Bearing repair offers shorter lead times than manufacturing new bearings.
- **Increased application uptime by detecting the origin of the problem.** Downtime in a mill may lead to extensive losses in production and revenue. When performed in a timely manner, bearing reconditioning helps reduce the potential for sudden equipment failures and subsequent downtime. Bearing inspection during the reconditioning process can establish the damage mode, which helps identify root problems within the application and avoids repeat occurrence.

IMPACT OF BEARING REPAIR ON PERFORMANCE

Fig. 276 shows how a bearing that goes without repair may reach a potential life as shown by the dotted red line. The black line shows the potential life increase of the bearing if it undergoes repairs throughout its service. Maintenance personnel always should evaluate the total repair cost involved compared to the expected life improvement to determine if repair is an economical choice.

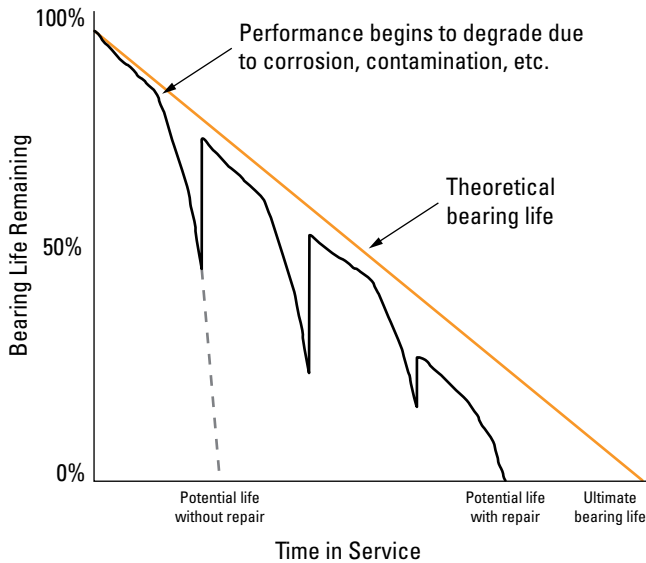

Fig. 276. Potential life comparison of bearings with and without repair.

Repair often is economical for roll neck bearings, which are designed to withstand very high loads, shocks and speeds. Depending on the operating conditions (i.e., overload) and environmental factors (i.e., mill stand condition, chock condition, lubrication), bearing life can vary dramatically from one mill to another, even among identical mill types.

Damage done to bearings from improper handling and installation, as well as damage caused by rolling solution ingress, improper setting, lubrication and operating conditions, creates the largest percentage of premature failure.

Before assessing any bearing for repair, you need to have a good understanding of different forms of bearing damage. Once you establish the nature of the failure at an early stage, you can take a suitable action to fix the bearing and avoid reoccurrence.

WHEN TO REPAIR A BEARING

Proper planning minimizes total bearing lifecycle costs. If you remove bearings from service too early, you won't use them to their full potential and you won't capture their useful remaining life. Conversely, leaving bearings in service too long increases the risk of operating them past the point of economical repair. Even more importantly, it puts your entire process in jeopardy with the risk of damaging other components in the system. Scrapping expensive components or experiencing unplanned downtime for hours, days or weeks can result from catastrophic failures that can be avoided. You maximize cost savings when you remove bearings from service at just the right time (fig. 277).

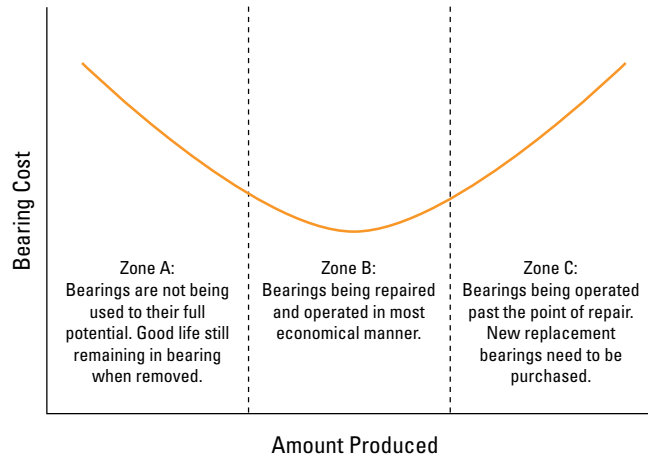

Fig. 277. Bearing operational stages – when to repair.

INDICATORS THAT BEARING ATTENTION IS REQUIRED

Some of the following scenarios indicate that a bearing may be ready for service or repair.

- **When the bearing exceeds suggested operating temperatures.** A continuous running temperature above the suggested levels indicates a problem that will impact proper lubrication. This is valid only if the temperature hasn't reached the point where heat will cause irreversible damage to the steel.
- **When any bearing component starts to show excessive vibration.** The bearing may be running with too much clearance or endplay. The contact of the rolling surfaces may experience spalling. Timely inspection and repair can reduce the potential for high vibration, which has a negative impact on product quality.
- **When there is a sudden lubricant drop or gain or excessive temperature of the oil in contact with the bearing.** This may be an indication of an abnormality in the bearing or the system that requires attention.

WHAT CANNOT BE REPAIRED OR IS NOT ECONOMICAL TO BE REPAIRED

It is not possible to repair every damaged bearing. Usually, in the following situations, components cannot be repaired:

- If there is evidence of overheating from improper mounting or removal.
- Heavy spalling exists on the extreme large end of the inner race of a tapered/cylindrical roller bearing.
- If there is any deep/heavy line or water etching across the raceway.
- If any spall is observed spread across the raceway.
- If extreme out-of-round conditions exist for outer-race O.D. and inner race bores.
- An inner race with an oversized bore can only be repaired with customer approval (loose cone fits).

Timken bearing repair types

Depending on the extent of damage, you may send a bearing to a Timken repair facility. Our experienced service engineers can assist your maintenance crew in macro assessing the damaged bearing and analyzing the root cause of the problem. In some instances, on-site repairs are possible. For times when you need in-depth, detailed repairs, we offer several repair types to suit various needs as described in table 18 below.

TABLE 18. TIMKEN RECONDITIONING TYPES AND WORK DESCRIPTION

Repair Type	Services Performed	Applicability
I	Bearings are cleaned, examined, measured for verification of internal clearances and preserved and packaged.	If bearing storage is > five years.
II	Bearings are cleaned, examined and measured for verification of internal clearances. Components are polished. Bearings are preserved and packaged.	Large bearing preventive maintenance.
III	Bearings are cleaned and examined. Raceways are reground and new roller sets are manufactured. Internal clearances are reset and bearings are preserved and packaged.	Large/expensive bearing or long lead times.
IV	Bearings are polished utilizing our proprietary vibratory process, then are preserved and packaged.	Large population of smaller bearings.
V	Bearings are cleaned, examined and measured for verification of internal clearances. Components are polished and cup races are reground. Bearings are preserved and packaged.	Large bearings.
VI	Special features may be added to existing or new bearing assemblies. These features are used to enhance performance, retrofit to special applications, or even upgrade to our most recent product designs.	Spacer modification, special coating, etc.
VII	Bearings are cleaned, inspected and measured for verification of internal clearances. Any stress risers or spalls discovered are hand relieved onsite and clearances are adjusted, if necessary.	On-site small damages.

TIMKEN REPAIR EXPERTISE

We back our commitment to providing high-quality repair and reclamation services with:

- **People.** Our repair engineers are highly trained and knowledgeable about repairing all types of bearings.
- **High-tech equipment.** Our state-of-the-art equipment helps maintain close tolerances and Original equipment manufacturers' specifications.
- **Engineering.** Our engineers specialized in products, applications, service, sales and manufacturing, work together to share best practices to maximize repair services.
- **Quality assurance.** Our repair operations are ISO-compliant. Our facilities' high-quality laser and gaging equipment can measure within a few microns.
- **New components.** We make all new components at our repair or manufacturing facilities and hold them to new Timken product quality standards. We make all components with qualified bearing-grade steels.
- **Heat treatment.** We perform heat treatment to the same specification as our new products.
- **Metallurgy.** Our full-time metallurgical staff provides support to our repair operations.
- **Computer-aided design.** Tools developed by our bearing design engineers determine geometry for reconditioning purposes and develop processing prints for repairing competitor's product back to original equipment manufacturers' standards.
- **Controls and detailed documentation.** We maintain an organized record-retention process for incoming inspections, process documentation, final inspections and assembly. We uniquely mark bearings for traceability.

ESTABLISHING AN INTEGRATED REPAIR PROGRAM

The most cost-effective program is one that integrates maintenance and repair of all mill-stand equipment, including bearings, chocks and rolls. Timken Services Group offers a full range of rebuild and remanufacturing capabilities to simplify your maintenance schedules. To find out how your company can benefit from an integrated repair and maintenance program, contact your Timken engineer.

CHOCK AND ROLL UPGRADES

We offer a variety of capabilities to produce new or remanufactured equipment (up to 50 tons) for steel and aluminum mills and other industrial equipment.

CHOCK AND ROLL REBUILDING SERVICES

Reliable component repair is essential to maximize uptime and plant performance. Beyond bearing repair and depending on the location, we offer chock maintenance and roll rebuilding. All of these services also may be integrated into the Timken MILLTEC® rolling mill program.

CHOCK AND BEARING MAINTENANCE

Our maintenance services help mill operators get the most out of their chock/bearing assembly.

We evaluate the assembly condition and provide an inspection report and quotation for chock and bearings before reconditioning begins.

The reconditioning consists of:

- Disassembly and cleaning.
- Inspecting and repairing all individual components.
- Reassembling, lubricating and repacking.
- Storing the assembled chocks based on customer requirements.

Additionally, and on your request, our maintenance experts can train your personnel on how to identify and prevent various types of damages.



Fig. 278. Chock maintenance before and after photos.

IMPROVING EXISTING CHOCKS

Our repair process can make a chock stronger than new with our mini- and full-rebuild services, all while saving you up to 60 percent off the cost of buying new. We work on hundreds of chocks each year and have the experience to assess and correct key problems that occur in work-roll and backup-roll chocks. Our full-service chock rebuild and manufacturing capabilities allow us to rework critical surfaces and return your equipment to like-new condition. We customize our services to meet specific needs. For example, we offer mini-rebuilds (rework of critical surfaces), full rebuilds (equipment returned to like-new condition) and the manufacture of new chocks.

We subject all work to three independent quality checks. Work comes with a one-year limited warranty.

ROLL OVERLAYS AND REPAIR

Timken Services Group's roll repair and overlay operations feature technological capabilities that deliver high-quality, reliable and cost-effective solutions to maximize customer's mill maintenance and production schedules. When original rolls are worn down to a minimum diameter, roll overlays can save in excess of 50 percent compared to the cost of scrapping them and buying new.

Through our dedicated roll facility, we remanufacture cast, forged-fabricated and weld-overlaid rolls for rolling mills. Our services accommodate a wide variety of roll applications and sizes.

Mill Clad Technology helps ensure metal consistency for increased life and optimal performance. Mill Clad is a highly engineered line of wear- and corrosion-resistant alloys that we apply to a roll's surface to improve life, resulting in lower roll costs per ton.

TIMKEN GEARS AND SERVICES

Timken Gears and Services is a globally recognized expert in power transmission solutions for the world's heavy industrial markets. We have a large installed base of drives through our proprietary brands (listed below) and provide mission-critical gear solutions for basic oxygen furnace (BOF) and other heavy applications in the metals industry.

With more than 120 years of design experience for critical heavy equipment in the power generation, infrastructure and military defense industries, Timken Gears and Services leverages our capabilities by offering world-class engineering and technical field service support for power transmission equipment. Our engineers utilize state-of-the-art inspection and measurement equipment as well as techniques that provide qualified answers to critical gear questions.

We repair virtually any gearbox make and model, with on-site emergency breakdown service available if needed. Whether it's a part of a predictive maintenance routine or if your gearbox shows signs of wear and increasing noise levels, it may be time for an in-depth inspection.

For more details, please contact your Timken engineer.



MILLTEC® ROLLING MILL PROGRAM

Through our customized MILLTEC® rolling mill program, you can concentrate on other important issues while we manage the mill's roll shop operations. Our on-site technicians help ensure minimal downtime due to roll changing, roll grinding, bearing overhaul and other maintenance procedures. MILLTEC is available for both hot and cold rolling mills and also can accommodate customers using oil film bearings.

MILLTEC offers customized service packages to deliver reduced cost-per-unit of output and improve profits. Depending on each mill's needs, the MILLTEC program can include the following services:

- Assembly and disassembly of bearings, chocks and chock assemblies on rolls.
- Periodic monitoring and maintenance of chock assemblies.
- Bearing repair.
- Grinding rolls and shear blades.
- Ultrasonic testing (UST) and eddy current testing (ECT) of rolls.
- Electro-discharging texturing (EDT) and shot blasting of rolls (as required).
- Record keeping and tracking rolls, chocks and bearings.
- Regular greasing and maintenance of mill drive spindles.
- Condition monitoring and equipment health management.
- Supply of roll shop consumables, including grease seals and gaskets.

Contact your Timken engineer to explore further options available with the MILLTEC rolling mill program.



Fig. 279. MILLTEC rolling mill program.

SERVICE ENGINEERING

Timken service engineers help keep you up to date by optimizing your bearings on all of your critical equipment. By knowing what's going on inside, you can maximize uptime and avoid unscheduled downtime.

Building on our metals industry knowledge and experience within our steelmaking and rolling mill facilities, our sales and service engineers help eliminate guesswork in maintaining steel and aluminum mills – improving your productivity.

Timken service engineers are trained and experienced in the practical issues of mounting, adjusting and maintaining bearings. We apply our application knowledge to bearing damage analysis to determine the root cause and suggest preventative solutions. Working on site with your design, maintenance and service personnel, Timken Service Engineers, help reduce maintenance costs and increase productivity and uptime.

Our service engineers are trained and certified in all applicable safety areas including personal protective equipment such as safety boots, high-visibility vests and heat-rated clothes.

TIMKEN ONLINE MONITORING SYSTEMS AND SERVICES

For the most critical assets in a plant, periodic predictive maintenance may not be frequent enough to ensure complete reliability. For systems such as overhead cranes, furnace fans and rolling mills, an unexpected failure can have safety, environmental and operational consequences. We offer a complete line of wired and wireless online monitoring solutions, including:

- Timken Online Intelligence System.
- Timken® StatusCheck® wireless condition monitoring.
- Custom-designed monitoring solutions.

TRAINING

Proper bearing handling and maintenance are critical to keeping equipment running and increasing productivity. Our engineers have in-depth knowledge of what needs to be done to optimize the life and performance of bearings in many types of equipment. These engineers are available for standard and customized training that suits your facility's particular needs.

Our training details the fundamentals of antifriction bearings, giving you the basics of how they operate and what you need to know to ensure maximum bearing life. We also offer maintenance application-specific training where bearings play a particularly crucial role and where we have special expertise.

ROLLING MILL TRAINING

This three-day program helps rolling mill maintenance teams and operators reduce maintenance costs and increase uptime. Training covers every phase of bearing performance in the rolling mill environment.

- Bearing fundamentals.
- Rolling mill configuration and design.
- Rolling mill related equipment.
- Bearing damage analysis.
- TQOW maintenance and hands-on instruction.
- TQITS demonstration.
- Gear drive bearing adjustment and assessment.
- Condition monitoring.

Following the course, you can request an audit to earn the Timken Bearing Certified designation.

INDUSTRIAL MAINTENANCE TRAINING

The performance and reliability of metals processing equipment depends directly on the condition of the bearings. Our industrial maintenance training program provides you with practical information you need to ensure that your bearings and equipment deliver reliable service at maximum performance levels.

You can schedule courses from a half day to two full days, and you can customize it to fit your needs. Following the course, you can request an audit to earn the Timken Bearing Certified designation.

BEARING CERTIFIED MAINTENANCE PROGRAM

To verify that your facility adheres to appropriate bearing maintenance practices, you can seek the designation Timken Bearing Certified. For in-house mill maintenance shops, the Bearing Certified designation confirms that you have solid processes and the appropriate equipment for proper bearing maintenance.

Prior to training, a Timken engineer conducts a pre-audit. This rigorous evaluation documents the quality of the processes and equipment you have in place to store, remove, install and maintain bearings.

We follow up training with a post-training audit by our engineer. Depending on how well your facility scores, you can earn one of several bearing certified levels. You'll also receive actionable information about any suggested improvements.

LEARN AND LEAD TECHNICAL TRAINING

This five-day course is ideal for design, reliability and maintenance engineers working for original equipment manufacturers of metal processing mills. It provides detailed classroom instruction and hands-on experiences related to bearing systems. Held near our global headquarters in Canton, Ohio, USA, the course also includes facility tours and open forum discussion groups.

BEARING MAINTENANCE TRAINING

Targeted to maintenance personnel at mills in Europe, these hands-on programs feature instruction on the proper methods to remove, install and maintain bearings (Bearing Maintenance and Adjustment Training) and how to store, handle and mount bearings (Bearing Mounting and Handling Training). We hold these two-day training sessions at our facilities in Colmar, France; Ploiesti, Romania; and customer locations.

TIMKEN

The Timken team applies their know-how to improve the reliability and performance of machinery in diverse markets worldwide. The company designs, makes and markets high-performance mechanical components, including bearings, gears, chain and related mechanical power transmission products and services.

www.timken.com



Stronger. Commitment. Stronger. Value. Stronger. Worldwide. Stronger. Together. | Stronger. By Design.